

6

5

4

3

2

1

| REVISION RECORD | | | |
|-----------------|---------|-----------|-------|
| LTR | ECO NO: | APPROVED: | DATE: |
| | | | |
| | | | |
| | | | |

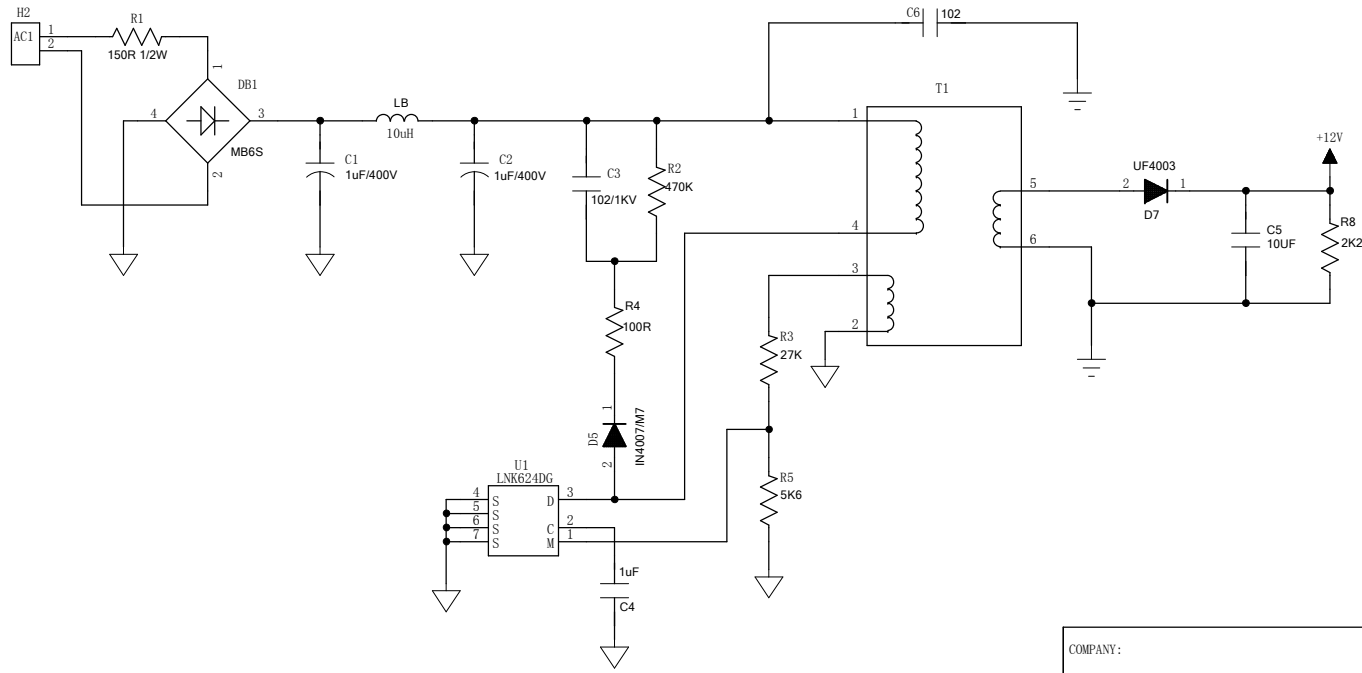

| | | | |
|----------|-------|-------------|---------------|
| COMPANY: | | | |
| TITLE: | | | |
| CODE: | SIZE: | DRAWING NO: | REV: |
| B | | | |
| SCALE: | | | SHEET: 1 OF 1 |

| | |
|------------------|--------|
| DRAWN: | DATED: |
| CHECKED: | DATED: |
| QUALITY CONTROL: | DATED: |
| RELEASED: | DATED: |

D

D

C

C

B

B

A

A