

# XL6001 DEMO Board manual

## Introduction

The document describes a high efficiency LED driver designed to drive an LED driver at a current of 320 mA from an input voltage range of 3.6 VDC to 20 VDC, output support 2~8 series 1W LED.

The XL6001 also provides a sophisticated range of protection features including output LED open faults and soft-start function. Accurate hysteretic thermal shutdown ensures safe average PCB temperatures under all conditions. Design with very low parts count.

This document contains the converter specification, schematic, PCB diagram, bill of materials.

## Schematic

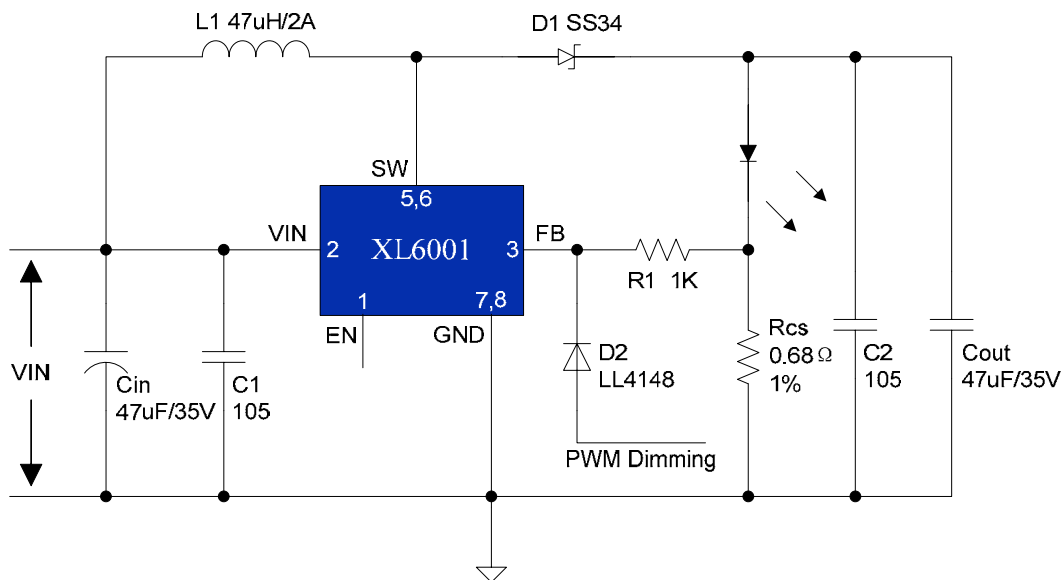

XL6001 VIN=DC3.6V~DC20V, IOU=320mA Typical Application Circuit

## Pin Description

Pin Number	Pin Name	Description
1	EN	Enable Pin. Drive EN pin low to turn off the device, drive it high to turn it on. Floating is default high.
2	VIN	Supply Voltage Input Pin. XL6001 operates from a 3.6V to 20V DC voltage.
3	FB	Feedback Pin (FB). The feedback threshold voltage is 0.22V.
4	NC	No Connected.
5,6	SW	Power Switch Output Pin (SW).
7,8	GND	Ground Pin.

## Bill of Materials

Item	Qty	Ref Des	Description	Mfg Part Number	Mfg
1	2	C1,C2	1uF,50V,Ceramic,X7R,0805	C2012X7R1H105K	TDK
2	1	Cin	47uF,35V,Electrolytic,(6.3x11)	YXA-35V-47uF	Rubycon
3	1	Cout	47uF,35V,Electrolytic,(6.3x11)	YXA-35V-47uF	Rubycon
4	1	D1	40V,3A,Schottky Rectifier, SMA	SS34	Fairchild
5	1	D2	100V, Switching diode, MINI MELF	LL4148	ICM
6	1	L1	47uH,2A,10*4		
7	1	R1	1K ,1%,1/8W, Thick Film,0805	RC0805xR-071001L	Yageo
8	1	RCS	0.68 ,1%,1/4W, Thick Film,1206	RC1206xR-07R680L	Yageo
9	1	U1	BOOST DC-DC LED Constant Current Driver,SOP-8L	XL6001	XLSEMI

## Performance Data

### Efficiency VS Load current

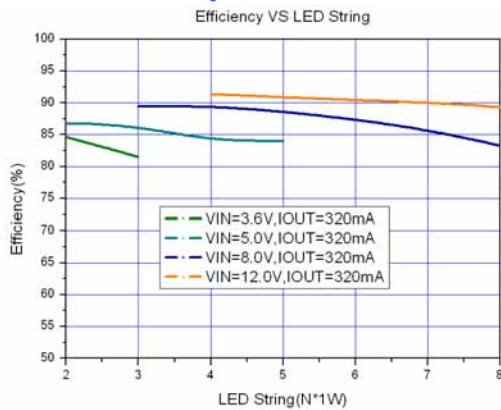

### Line and Load Regulation

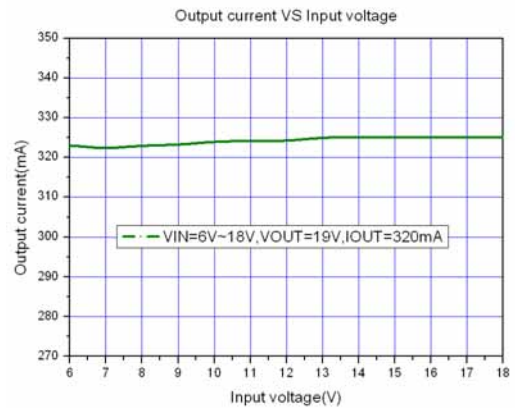

## Populated Circuit Board Phtograph



PCBLAYOUT

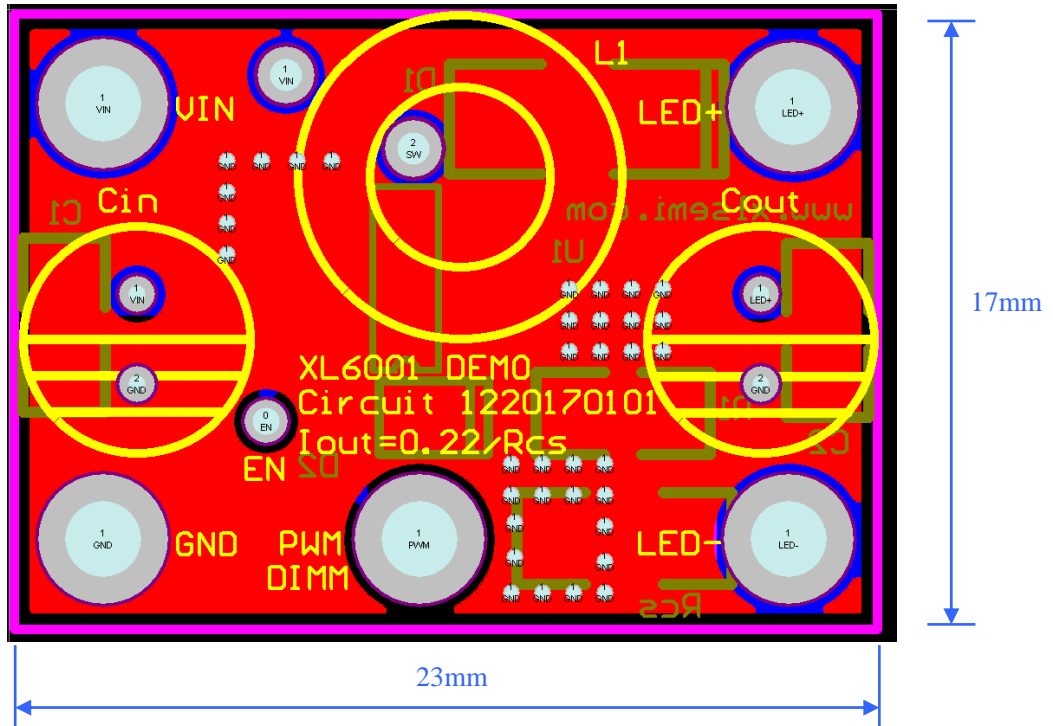

Top side

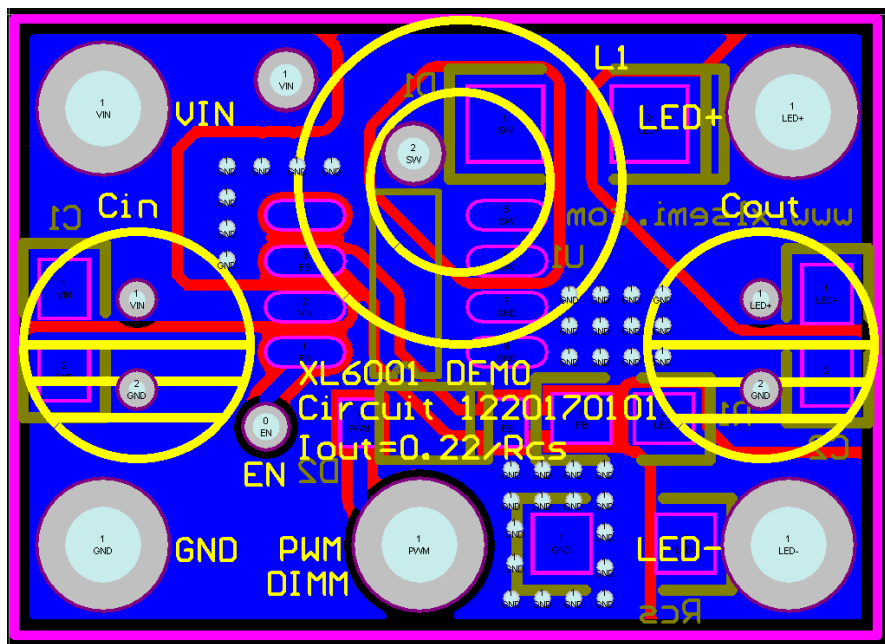

Bottom side

Note :

1. Keep feedback wiring away from inductor and schottky.
2. VIN, SW, LED+, LED- lines must be short and ground plane construction for best results.
3. D2,R1 are used for the designing with PWM dimming. If not with PWM dimming, R1 replaced with 0 ohm, D2 open.