

Title		
24-Port Diagram of MAX5980 PSE		
Size	Number	Revision
A		
Date:	26-Oct-2011	Sheet of
File:	D:\work\MAX5980 24Port PSE\MAX5980 24PORT PSE.ddb	Drawn by

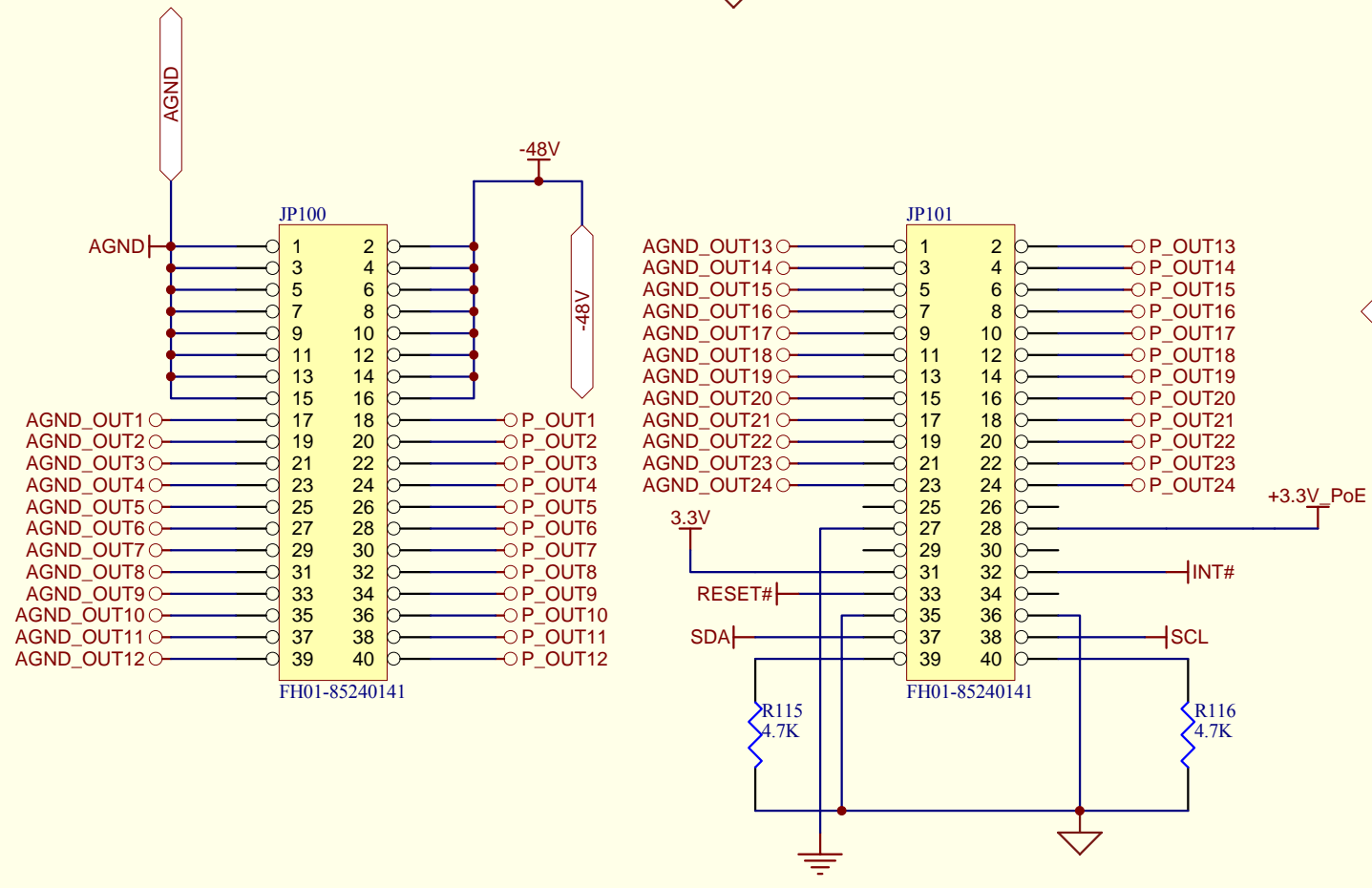
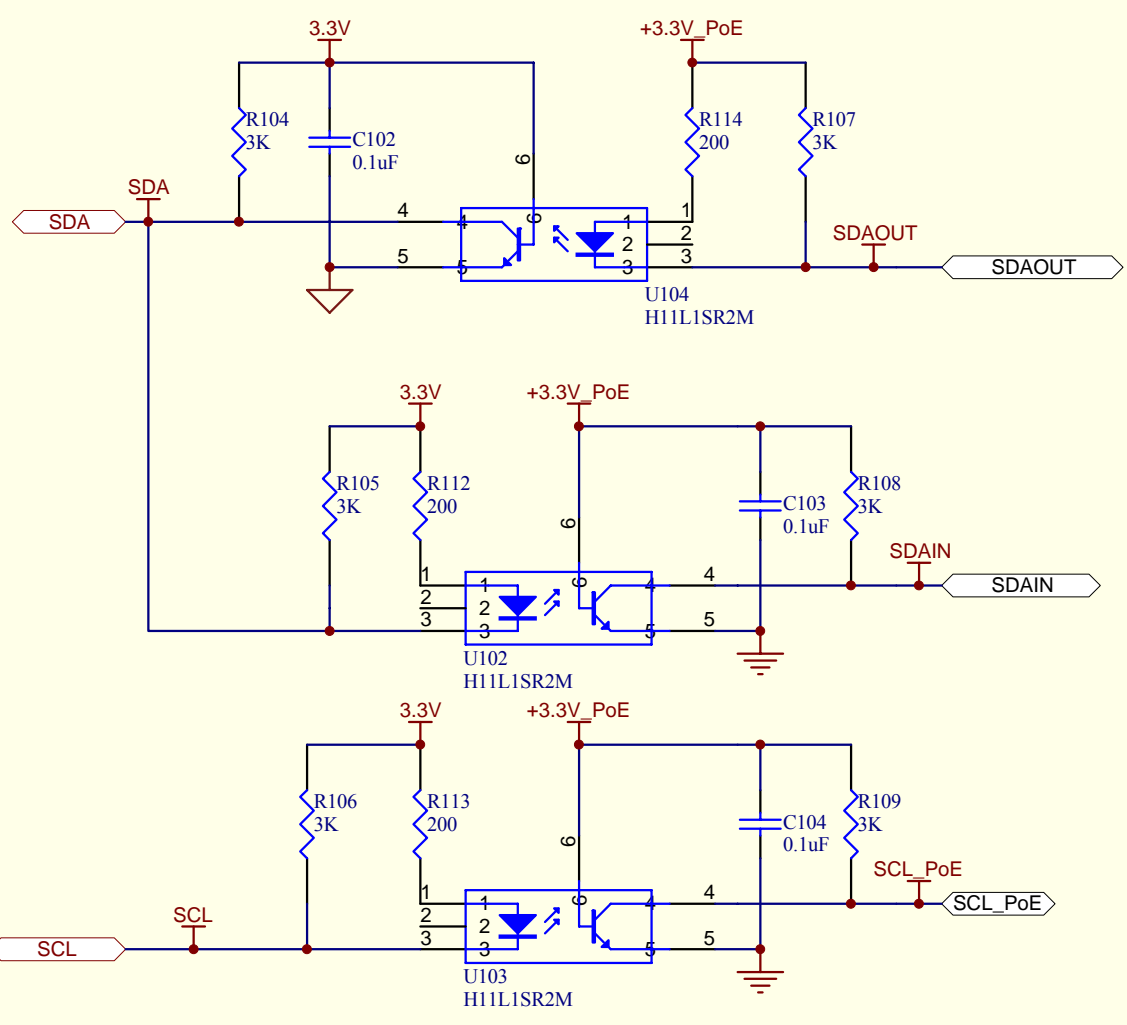
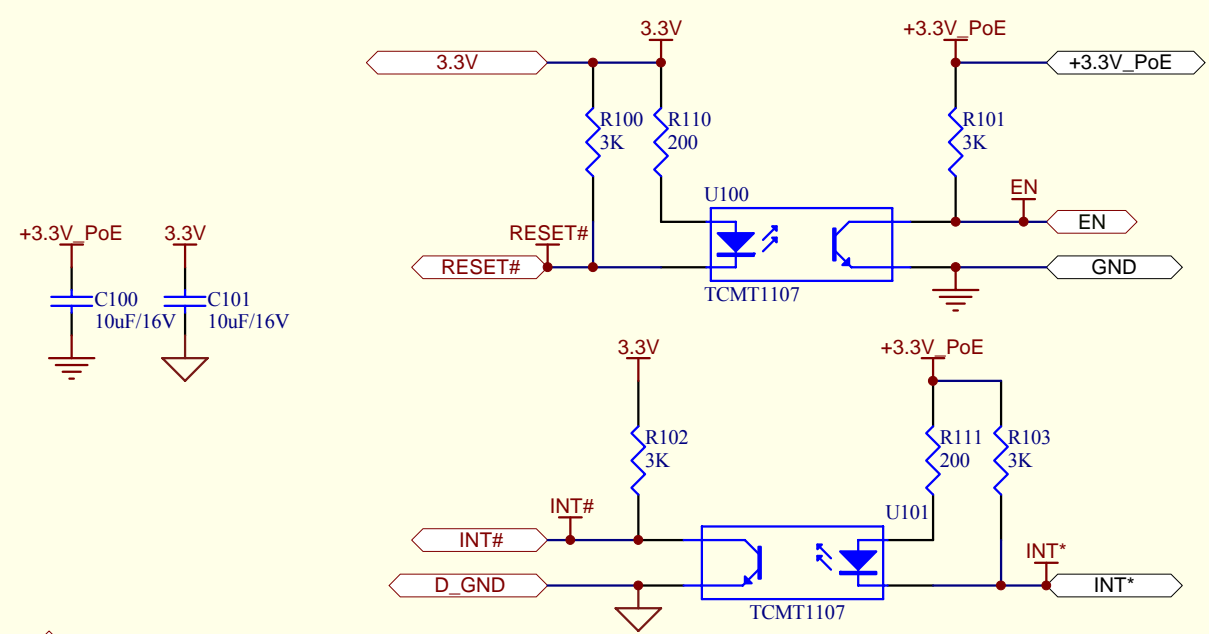

CONNECTOR CIRCUIT

ISOLATION CIRCUIT OF MAX5980 PSE ICM

Title		
Size	Number	Revision
A4		
Date:	26-Oct-2011	Sheet of
File:	D:\work\MAX5980 24Port PSE\MAX5980 24PORT PSE.ddb	24 of 24

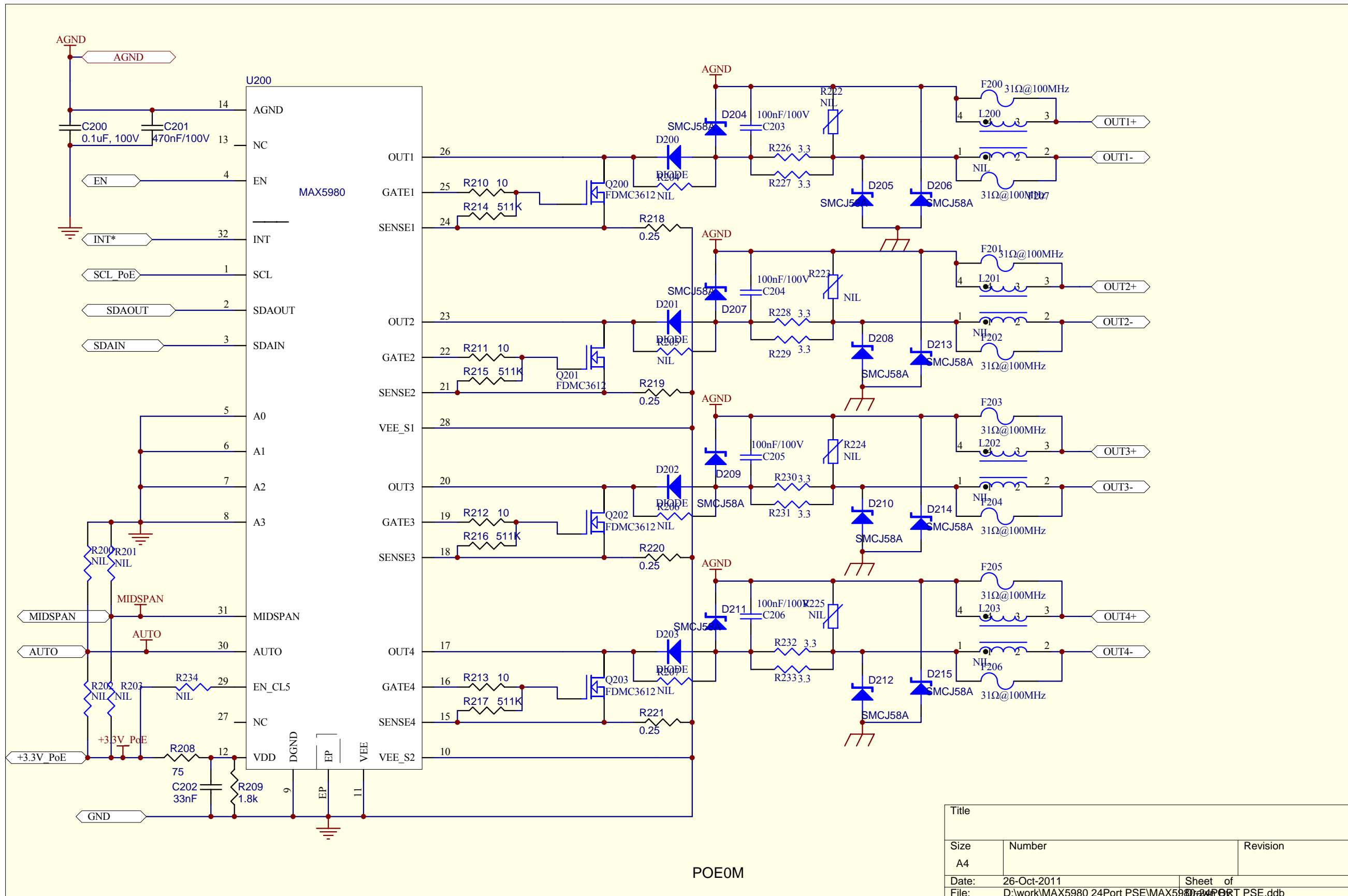

Title		
Size	Number	Revision
A4		
Date:	26-Oct-2011	Sheet of
File:	D:\work\MAX5980 24Port PSE\MAX5980 24PORT PSE.ddb	

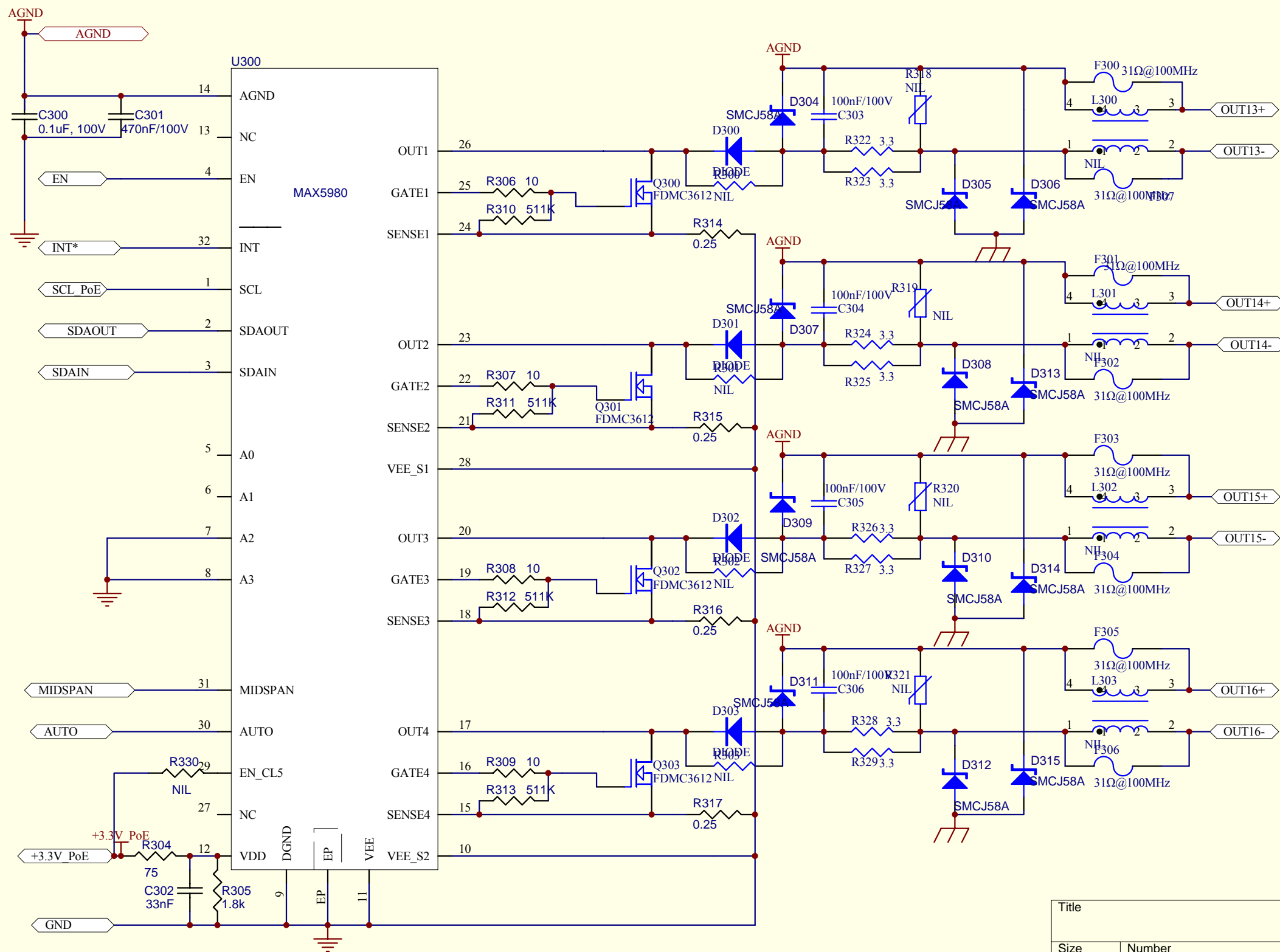

POE3M

Title		
Size	Number	Revision
A4		
Date:	26-Oct-2011	Sheet of
File:	D:\work\MAX5980 24Port PSE\MAX5980 24PORT PSE.ddb	

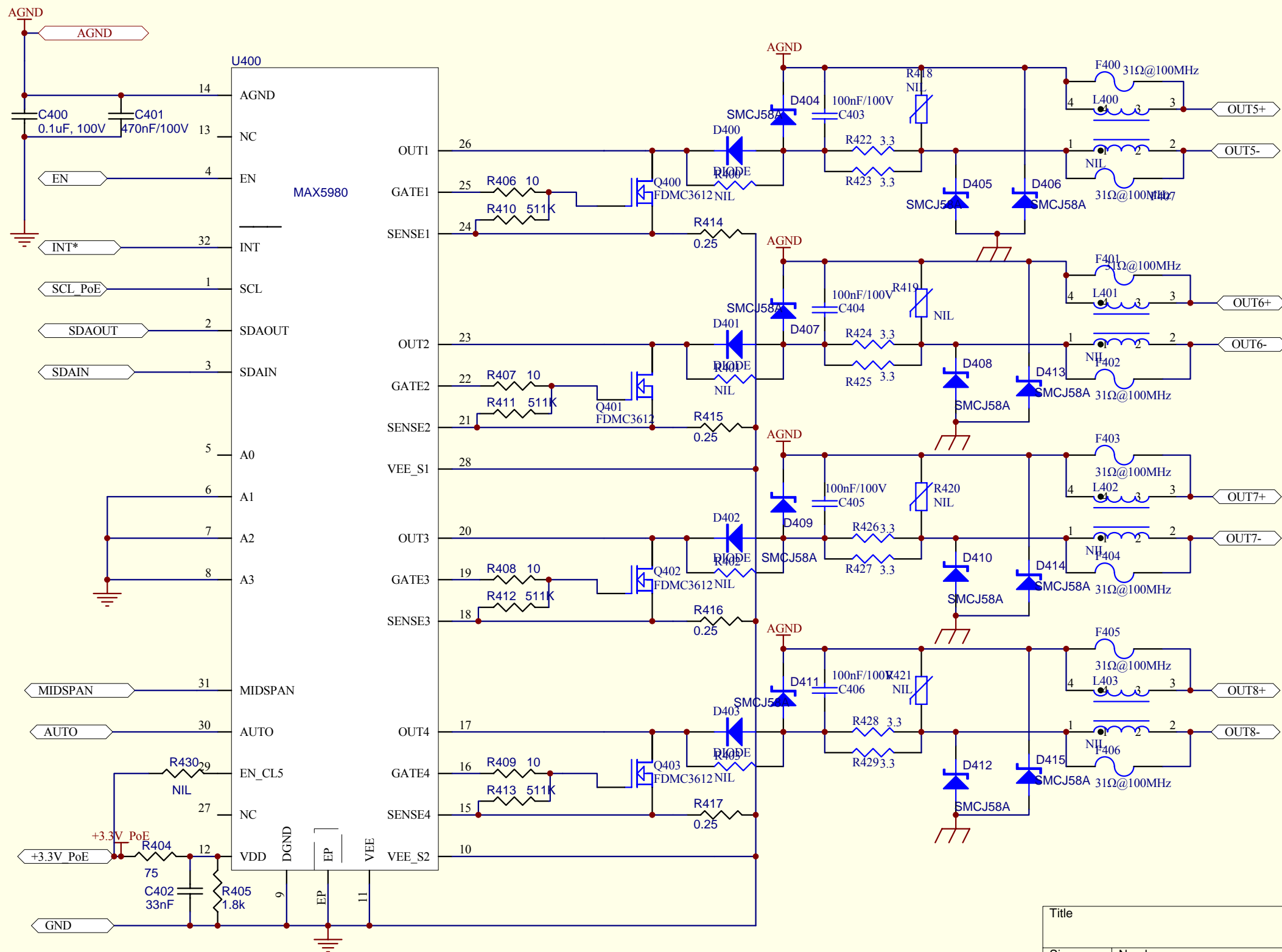

POE1M

Title		
Size	Number	Revision
A4		
Date:	26-Oct-2011	Sheet of
File:	D:\work\MAX5980 24Port PSE\MAX5980 24Port PSE.ddb	

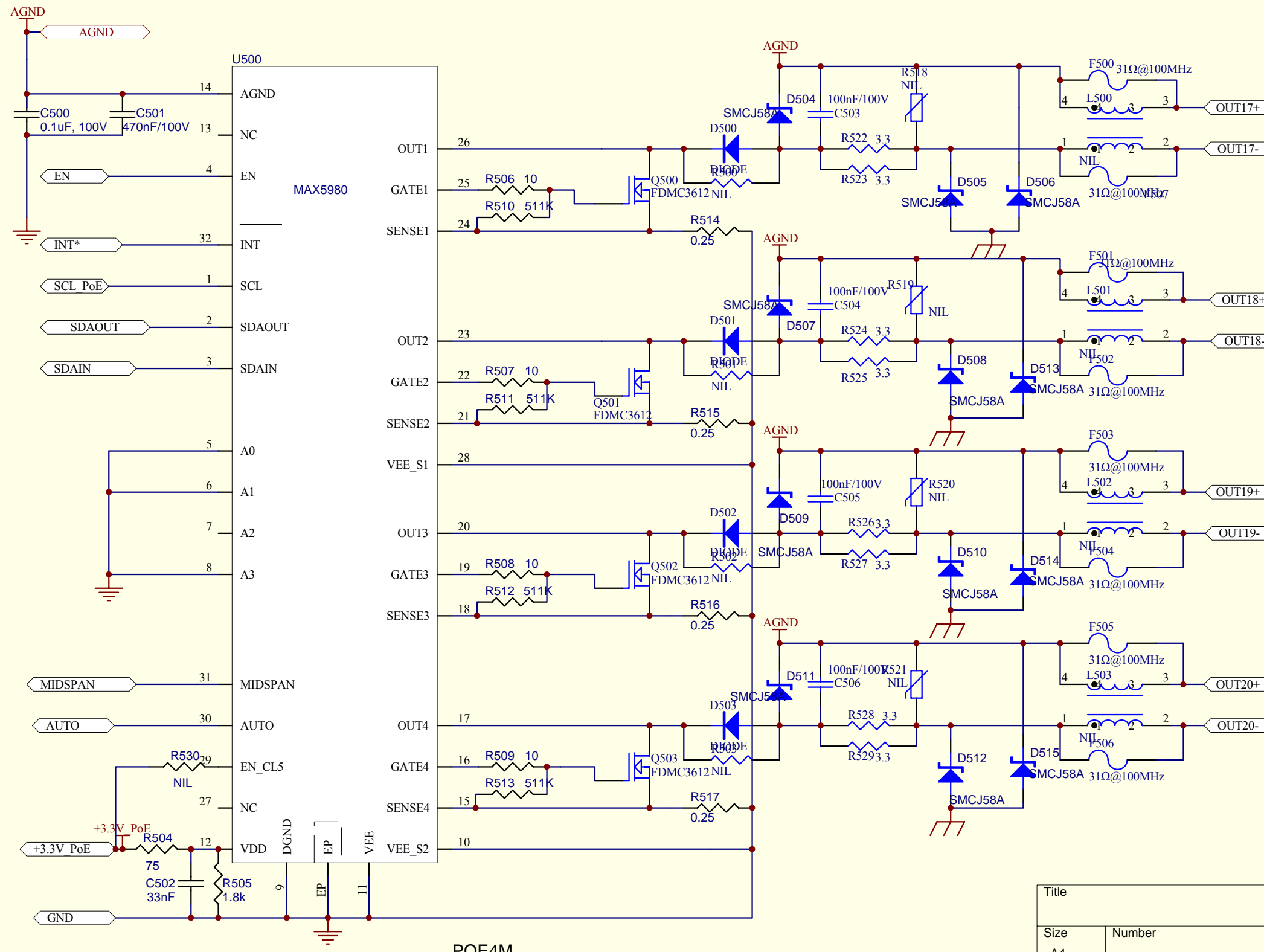

POE4M

Title		
Size	Number	Revision
A4		
Date:	26-Oct-2011	Sheet of
File:	D:\work\MAX5980 24Port PSE\MAX5980 24PORT PSE.ddb	2 of 2

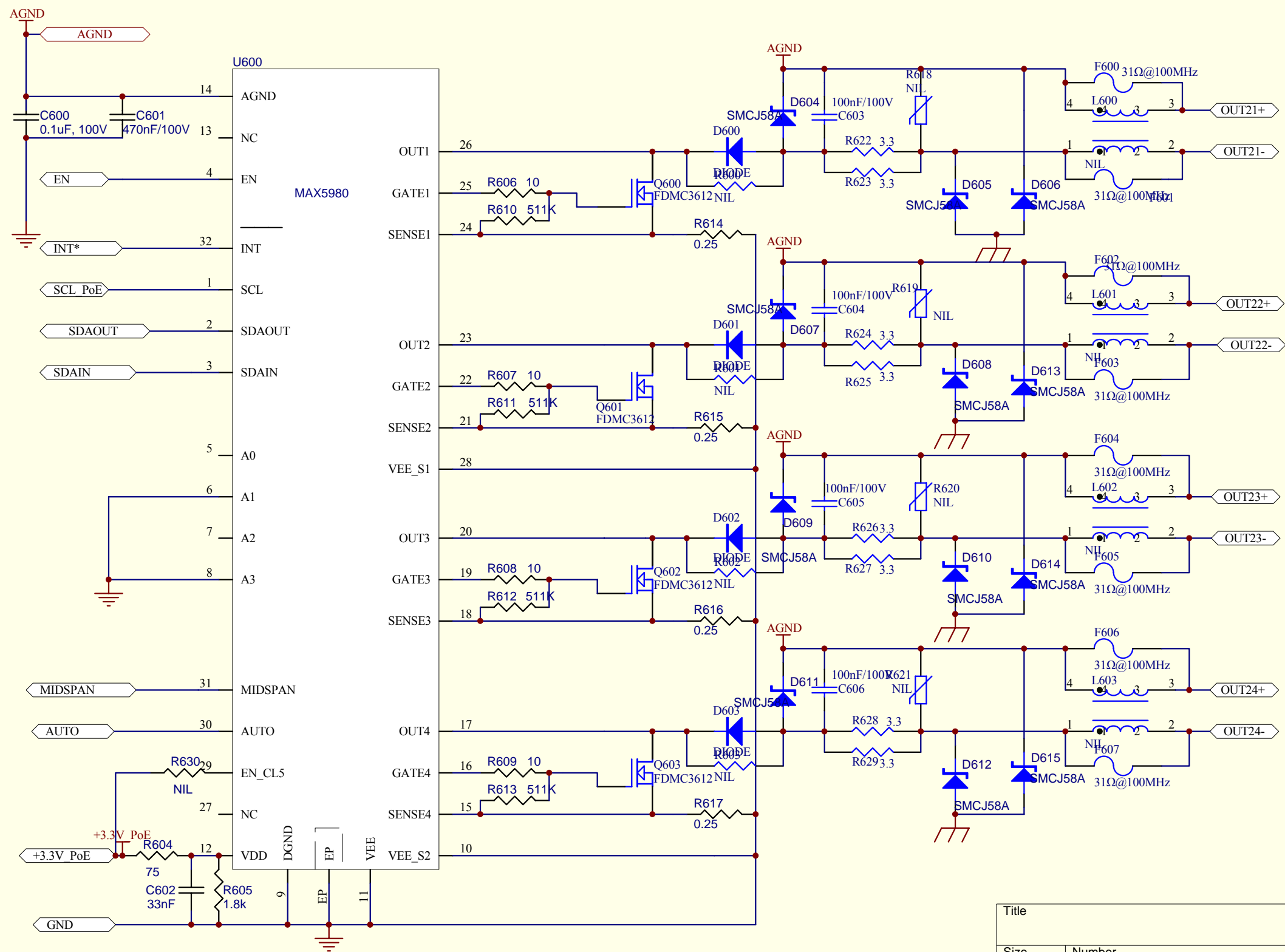

POE5M

Title		
Size	Number	Revision
A4		
Date:	26-Oct-2011	Sheet of
File:	D:\work\MAX5980 24Port PSE\MAX5980 24Port PSE.ddb	

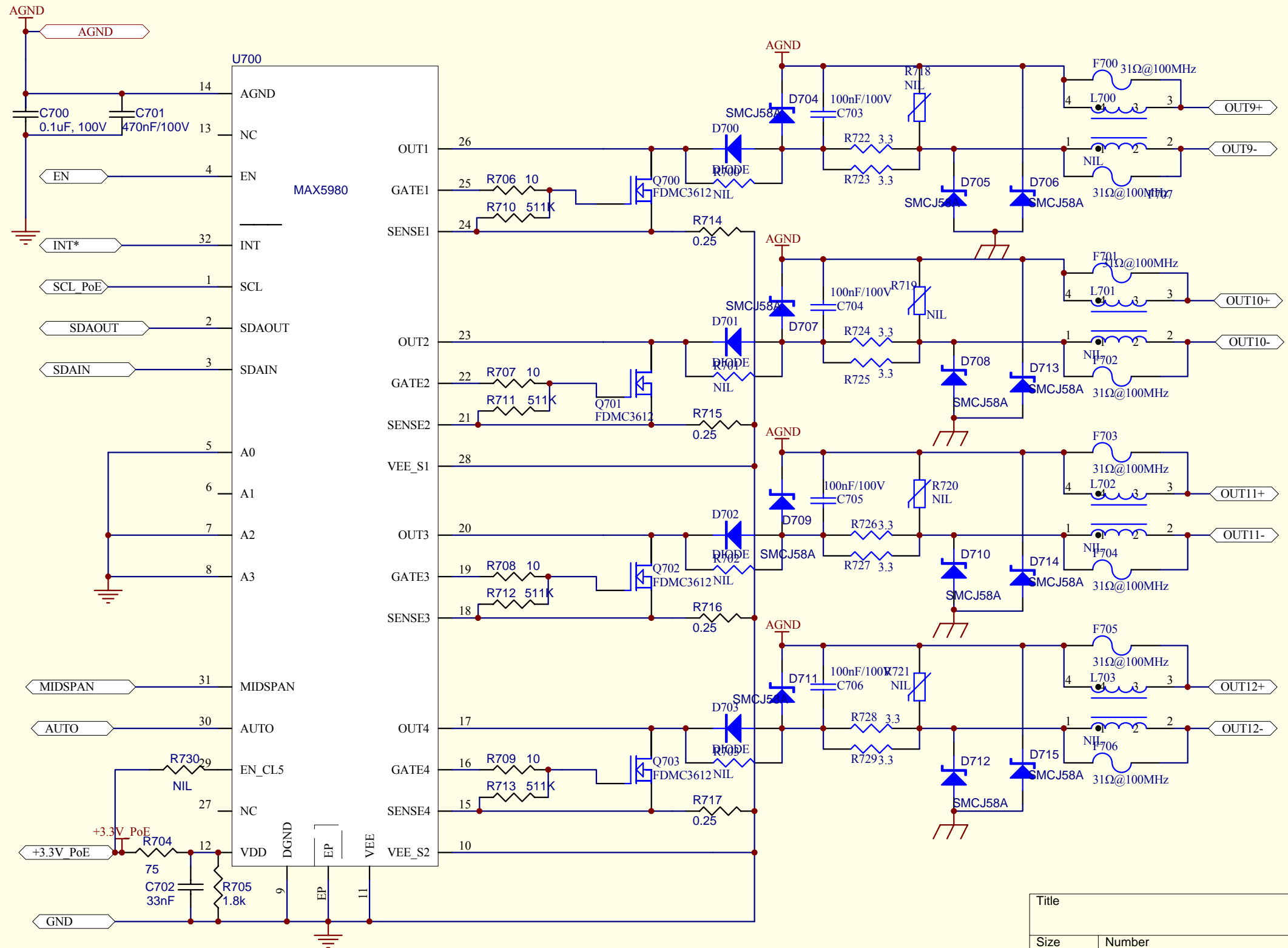

POE2M

Title		
Size	Number	Revision
A4		
Date:	26-Oct-2011	Sheet of
File:	D:\work\MAX5980 24Port PSE\MAX5980 24Port PSE.ddb	24 of 24

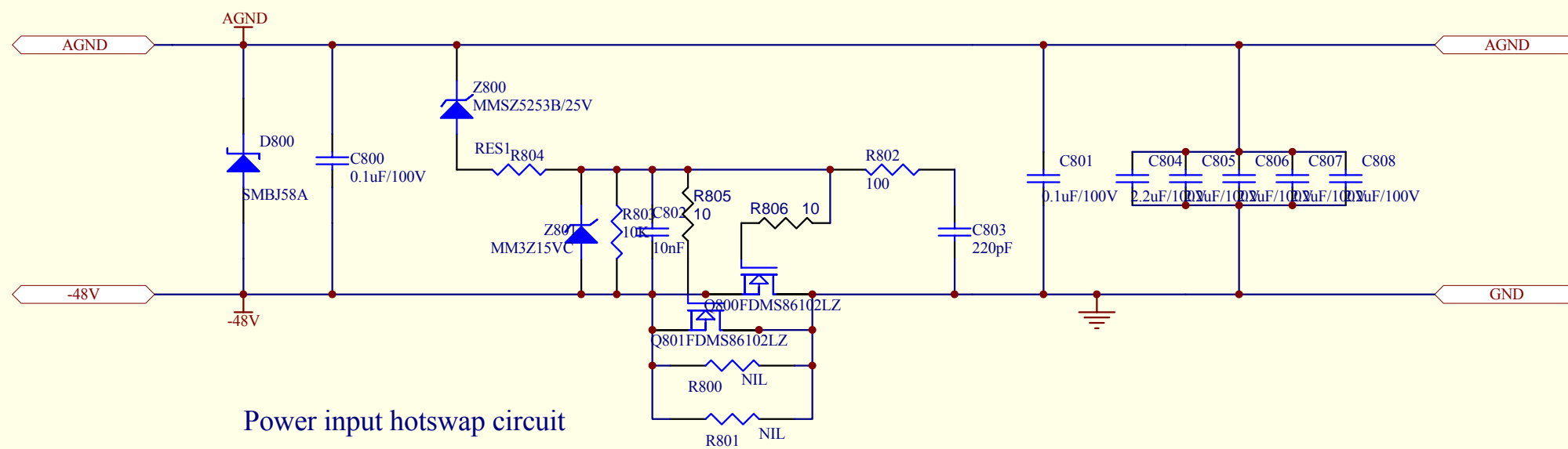

Power input hotswap circuit

Title		
Size	Number	Revision
A4		
Date:	26-Oct-2011	Sheet of
File:	D:\work\MAX5980 24Port PSE\MAX5980 24Port PSE.ddb	