

Contents

Index Pages

Section 1

Section 2

Section 3

Section 4

Section 5

Section 6

Core Locator (Toroids) by Part Number

Core Locator (Toroids) by Size

General Information

- 1-1 Introduction
- 1-2 Applications
- 1-3 Core Identification
- 1-4 General Powder Core Information

Core Selection

- 2-1 Inductor Core Selection Procedure
- 2-2 Core Selection Example
- 2-3 Core Selection Charts
- 2-6 Designing with Magnetics Powder Cores
- 2-8 Powder Core Loss Calculation

Technical Data

- 3-1 Material Properties
- 3-2 Conversion Tables
- 3-3 Normal Magnetization Curves
- 3-6 Core Loss Density Curves
- 3-14 Permeability versus Temperature Curves
- 3-18 Permeability versus DC Bias Curves
- 3-21 Permeability versus AC Flux Curves
- 3-25 Permeability versus Frequency Curves
- 3-28 Wire Table

Core Data

- 4-1 Toroid Data
- 4-36 Kool M μ [®] E Core Data
- 4-38 Kool M μ [®] U Core Data
- 4-39 Kool M μ [®] Segment Data
- 4-40 MPP THINZ[®] Data

Hardware

- 5-1 E Core Hardware
- 5-2 Toroid Hardware

General Winding Data

- 6-1 Winding Tables



Core Locator & Unit Pack Quantity

MPP (Toroids)

P/N	PAGE	QTY	P/N	PAGE	QTY	P/N	PAGE	QTY	P/N	PAGE	QTY	P/N	PAGE	QTY
55014	4-4	10,000	55104	4-28	90	55200	4-16	1,600	55304	4-17	1,000	55542	4-20	250
55015	4-4	10,000	55106	4-28	90	55201	4-16	1,600	55305	4-17	1,000	55543	4-20	250
55016	4-4	10,000	55107	4-28	90	55202	4-16	1,600	55306	4-17	1,000	55544	4-20	250
55017	4-4	10,000	55108	4-28	90	55203	4-16	1,600	55307	4-17	1,000	55545	4-20	250
55018	4-4	10,000	55109	4-28	90	55204	4-16	1,600	55308	4-17	1,000	55546	4-20	250
55019	4-4	10,000	55110	4-28	90	55205	4-16	1,600	55309	4-17	1,000	55547	4-20	250
55020	4-4	10,000	55111	4-28	90	55206	4-16	1,600	55310	4-17	1,000	55548	4-20	250
55021	4-4	10,000	55112	4-28	90	55208	4-16	1,600	55312	4-17	1,000	55550	4-20	250
55022	4-4	10,000	55114	4-28	90	55209	4-16	1,600	55313	4-17	1,000	55551	4-20	250
55023	4-4	10,000	55115	4-14	2,000	55234	4-5	10,000	55318	4-22	220	55579	4-21	300
55024	4-8	10,000	55116	4-14	2,000	55235	4-5	10,000	55319	4-22	220	55580	4-21	300
55025	4-8	10,000	55117	4-14	2,000	55236	4-5	10,000	55320	4-22	220	55581	4-21	300
55026	4-8	10,000	55118	4-14	2,000	55237	4-5	10,000	55321	4-22	220	55582	4-21	300
55027	4-8	10,000	55119	4-14	2,000	55238	4-5	10,000	55322	4-22	220	55583	4-21	300
55028	4-8	10,000	55120	4-14	2,000	55239	4-5	10,000	55323	4-22	220	55584	4-21	300
55029	4-8	10,000	55121	4-14	2,000	55240	4-5	10,000	55324	4-22	220	55585	4-21	300
55030	4-8	10,000	55122	4-14	2,000	55241	4-5	10,000	55326	4-22	220	55586	4-21	300
55031	4-8	10,000	55123	4-14	2,000	55242	4-5	10,000	55327	4-22	220	55587	4-21	300
55032	4-8	10,000	55124	4-14	2,000	55243	4-5	10,000	55336	4-34	10	55588	4-21	300
55033	4-8	10,000	55125	4-12	6,000	55248	4-23	180	55337	4-34	10	55614	4-29	50
55034	4-8	10,000	55127	4-12	6,000	55249	4-23	180	55339	4-34	10	55615	4-29	50
55035	4-11	8,000	55128	4-12	6,000	55250	4-23	180	55340	4-34	10	55617	4-29	50
55036	4-11	8,000	55129	4-12	6,000	55251	4-23	180	55344	4-18	480	55620	4-29	50
55037	4-11	8,000	55130	4-12	6,000	55252	4-23	180	55345	4-18	480	55709	4-26	90
55038	4-11	8,000	55131	4-12	6,000	55253	4-23	180	55347	4-18	480	55710	4-26	90
55039	4-11	8,000	55132	4-12	6,000	55254	4-23	180	55348	4-18	480	55712	4-26	90
55040	4-11	8,000	55133	4-12	6,000	55256	4-23	180	55349	4-18	480	55713	4-26	90
55041	4-11	8,000	55134	4-12	6,000	55257	4-23	180	55350	4-18	480	55714	4-26	90
55042	4-11	8,000	55135	4-1	7,500	55264	4-6	10,000	55351	4-18	480	55715	4-26	90
55043	4-11	8,000	55137	4-1	7,500	55265	4-6	10,000	55352	4-18	480	55716	4-26	90
55044	4-11	8,000	55138	4-1	7,500	55266	4-6	10,000	55353	4-18	480	55717	4-26	90
55045	4-13	5,000	55139	4-1	7,500	55267	4-6	10,000	55374	4-15	2,000	55718	4-26	90
55046	4-13	5,000	55140	4-1	7,500	55268	4-6	10,000	55375	4-15	2,000	55734	4-30	20
55047	4-13	5,000	55144	4-2	7,500	55269	4-6	10,000	55377	4-15	2,000	55735	4-30	20
55048	4-13	5,000	55145	4-2	7,500	55270	4-6	10,000	55378	4-15	2,000	55737	4-30	20
55049	4-13	5,000	55147	4-2	7,500	55271	4-6	10,000	55379	4-15	2,000	55740	4-30	20
55050	4-13	5,000	55148	4-2	7,500	55272	4-6	10,000	55380	4-15	2,000	55848	4-16	1,600
55051	4-13	5,000	55149	4-2	7,500	55273	4-6	10,000	55381	4-15	2,000	55866	4-31	45
55052	4-13	5,000	55150	4-2	7,500	55274	4-9	8,000	55382	4-15	2,000	55867	4-31	45
55053	4-13	5,000	55164	4-35	5	55275	4-9	8,000	55383	4-15	2,000	55868	4-31	45
55059	4-17	1,000	55165	4-35	5	55276	4-9	8,000	55404	4-7	10,000	55869	4-31	45
55071	4-20	250	55167	4-35	5	55277	4-9	8,000	55405	4-7	10,000	55894	4-19	400
55076	4-22	220	55168	4-35	5	55278	4-9	8,000	55407	4-7	10,000	55906	4-32	40
55082	4-22	220	55174	4-3	5,000	55279	4-9	8,000	55408	4-7	10,000	55907	4-32	40
55083	4-23	180	55175	4-3	5,000	55280	4-9	8,000	55409	4-7	10,000	55908	4-32	40
55084	4-25	120	55177	4-3	5,000	55281	4-9	8,000	55410	4-7	10,000	55909	4-32	40
55086	4-25	120	55178	4-3	5,000	55282	4-9	8,000	55411	4-7	10,000	55924	4-19	400
55087	4-25	120	55179	4-3	5,000	55283	4-9	8,000	55412	4-7	10,000	55925	4-19	400
55088	4-25	120	55180	4-3	5,000	55284	4-9	8,000	55413	4-7	10,000	55926	4-19	400
55089	4-25	120	55181	4-3	5,000	55285	4-10	8,000	55432	4-24	105	55927	4-19	400
55090	4-25	120	55190	4-27	80	55286	4-10	8,000	55433	4-24	105	55928	4-19	400
55091	4-25	120	55191	4-27	80	55287	4-10	8,000	55435	4-24	105	55929	4-19	400
55092	4-25	120	55192	4-27	80	55288	4-10	8,000	55436	4-24	105	55930	4-19	400
55098	4-33	25	55195	4-27	80	55289	4-10	8,000	55437	4-24	105	55932	4-19	400
55099	4-33	25	55196	4-27	80	55290	4-10	8,000	55438	4-24	105	55933	4-19	400
55101	4-33	25	55197	4-27	80	55291	4-10	8,000	55439	4-24	105			
55102	4-33	25	55198	4-27	80	55292	4-10	8,000	55440	4-24	105			
55103	4-28	90	55199	4-27	80	55293	4-10	8,000	55441	4-24	105			

Core Locator & Unit Pack Quantity

High Flux (Toroids)

P/N	PAGE	QTY	P/N	PAGE	QTY	P/N	PAGE	QTY
58018	4-4	10,000	58191	4-27	80	58378	4-15	2,000
58019	4-4	10,000	58192	4-27	80	58379	4-15	2,000
58020	4-4	10,000	58195	4-27	80	58380	4-15	2,000
58021	4-4	10,000	58204	4-16	1,600	58381	4-15	2,000
58022	4-4	10,000	58205	4-16	1,600	58382	4-15	2,000
58023	4-4	10,000	58206	4-16	1,600	58383	4-15	2,000
58028	4-8	10,000	58208	4-16	1,600	58408	4-7	10,000
58029	4-8	10,000	58209	4-16	1,600	58409	4-7	10,000
58030	4-8	10,000	58238	4-5	10,000	58410	4-7	10,000
58031	4-8	10,000	58239	4-5	10,000	58411	4-7	10,000
58032	4-8	10,000	58240	4-5	10,000	58412	4-7	10,000
58033	4-8	10,000	58241	4-5	10,000	58413	4-7	10,000
58038	4-11	8,000	58242	4-5	10,000	58437	4-24	105
58039	4-11	8,000	58243	4-5	10,000	58438	4-24	105
58040	4-11	8,000	58252	4-23	180	58439	4-24	105
58041	4-11	8,000	58253	4-23	180	58440	4-24	105
58042	4-11	8,000	58254	4-23	180	58441	4-24	105
58043	4-11	8,000	58256	4-23	180	58546	4-20	250
58048	4-13	5,000	58257	4-23	180	58547	4-20	250
58049	4-13	5,000	58268	4-6	10,000	58548	4-20	250
58050	4-13	5,000	58269	4-6	10,000	58550	4-20	250
58051	4-13	5,000	58270	4-6	10,000	58551	4-20	250
58052	4-13	5,000	58271	4-6	10,000	58583	4-21	300
58053	4-13	5,000	58272	4-6	10,000	58584	4-21	300
58059	4-17	1,000	58273	4-6	10,000	58585	4-21	300
58071	4-20	250	58278	4-9	8,000	58586	4-21	300
58076	4-22	220	58279	4-9	8,000	58587	4-21	300
58083	4-23	180	58280	4-9	8,000	58588	4-21	300
58089	4-25	120	58281	4-9	8,000	58614	4-29	50
58090	4-25	120	58282	4-9	8,000	58615	4-29	50
58091	4-25	120	58283	4-9	8,000	58617	4-29	50
58092	4-25	120	58288	4-10	8,000	58620	4-29	50
58098	4-33	25	58289	4-10	8,000	58714	4-26	90
58099	4-33	25	58290	4-10	8,000	58715	4-26	90
58101	4-33	25	58291	4-10	8,000	58716	4-26	90
58102	4-33	25	58292	4-10	8,000	58717	4-26	90
58109	4-28	90	58293	4-10	8,000	58718	4-26	90
58110	4-28	90	58308	4-17	1,000	58734	4-30	20
58111	4-28	90	58309	4-17	1,000	58735	4-30	20
58112	4-28	90	58310	4-17	1,000	58737	4-30	20
58118	4-14	2,000	58312	4-17	1,000	58740	4-30	20
58119	4-14	2,000	58313	4-17	1,000	58848	4-16	1,600
58120	4-14	2,000	58322	4-22	220	58866	4-31	45
58121	4-14	2,000	58323	4-22	220	58867	4-31	45
58122	4-14	2,000	58324	4-22	220	58868	4-31	45
58123	4-14	2,000	58326	4-22	220	58869	4-31	45
58128	4-12	6,000	58327	4-22	220	58894	4-19	400
58129	4-12	6,000	58336	4-34	10	58906	4-32	40
58130	4-12	6,000	58337	4-34	10	58907	4-32	40
58131	4-12	6,000	58339	4-34	10	58908	4-32	40
58132	4-12	6,000	58340	4-34	10	58909	4-32	40
58133	4-12	6,000	58348	4-18	480	58928	4-19	400
58164	4-35	5	58349	4-18	480	58929	4-19	400
58165	4-35	5	58350	4-18	480	58930	4-19	400
58167	4-35	5	58351	4-18	480	58932	4-19	400
58168	4-35	5	58352	4-18	480	58933	4-19	400
58190	4-27	80	58353	4-18	480			

Core Locator & Unit Pack Quantity

Kool M μ [®] (Toroids)

P/N	PAGE	QTY
77020	4-4	10,000
77021	4-4	10,000
77030	4-8	10,000
77031	4-8	10,000
77040	4-11	8,000
77041	4-11	8,000
77050	4-13	5,000
77051	4-13	5,000
77054	4-13	5,000
77055	4-13	5,000
77059	4-17	1,000
77071	4-20	250
77076	4-22	220
77083	4-23	180
77089	4-25	120
77090	4-25	120
77091	4-25	120
77093	4-25	120
77094	4-25	120
77095	4-25	120
77098	4-33	25
77099	4-33	25
77100	4-33	25
77102	4-33	25
77109	4-28	90
77110	4-28	90
77111	4-28	90
77120	4-14	2,000
77121	4-14	2,000
77130	4-12	6,000
77131	4-12	6,000
77140	4-1	7,500
77141	4-1	7,500
77150	4-2	7,500
77151	4-2	7,500
77154	4-2	7,500
77155	4-2	7,500
77165	4-35	5
77166	4-35	5
77180	4-3	5,000
77181	4-3	5,000
77184	4-3	5,000
77185	4-3	5,000
77189	4-27	80
77191	4-27	80
77192	4-27	80
77193	4-27	80
77194	4-27	80
77195	4-27	80
77206	4-16	1,600
77210	4-16	1,600
77211	4-16	1,600
77212	4-28	90
77213	4-28	90

P/N	PAGE	QTY
77214	4-28	90
77224	4-14	2,000
77225	4-14	2,000
77240	4-5	10,000
77241	4-5	10,000
77244	4-5	10,000
77245	4-5	10,000
77254	4-23	180
77256	4-23	180
77258	4-23	180
77259	4-23	180
77260	4-23	180
77270	4-6	10,000
77271	4-6	10,000
77280	4-9	8,000
77281	4-9	8,000
77290	4-10	8,000
77291	4-10	8,000
77294	4-10	8,000
77295	4-10	8,000
77310	4-17	1,000
77312	4-17	1,000
77314	4-17	1,000
77315	4-17	1,000
77316	4-17	1,000
77324	4-22	220
77326	4-22	220
77328	4-22	220
77329	4-22	220
77330	4-22	220
77334	4-12	6,000
77335	4-12	6,000
77337	4-34	10
77338	4-34	10
77339	4-34	10
77350	4-18	480
77351	4-18	480
77352	4-18	480
77354	4-18	480
77355	4-18	480
77356	4-18	480
77380	4-15	2,000
77381	4-15	2,000
77384	4-15	2,000
77385	4-15	2,000
77410	4-7	10,000
77411	4-7	10,000
77414	4-7	10,000
77415	4-7	10,000
77431	4-24	105
77438	4-24	105
77439	4-24	105
77440	4-24	105
77442	4-24	105

P/N	PAGE	QTY
77443	4-24	105
77444	4-1	7,500
77445	4-1	7,500
77548	4-20	250
77550	4-20	250
77552	4-20	250
77553	4-20	250
77555	4-20	250
77585	4-21	300
77586	4-21	300
77587	4-21	300
77589	4-21	300
77590	4-21	300
77591	4-21	300
77615	4-29	50
77616	4-29	50
77617	4-29	50
77618	4-29	50
77619	4-29	50
77715	4-26	90
77716	4-26	90
77717	4-26	90
77719	4-26	90
77720	4-26	90
77721	4-26	90
77735	4-30	20
77736	4-30	20
77737	4-30	20
77738	4-30	20
77739	4-30	20
77824	4-4	10,000
77825	4-4	10,000
77834	4-8	10,000
77835	4-8	10,000
77844	4-11	8,000
77845	4-11	8,000
77847	4-16	1,600
77848	4-16	1,600
77867	4-31	45
77868	4-31	45
77872	4-31	45
77874	4-6	10,000
77875	4-6	10,000
77884	4-6	10,000
77885	4-6	10,000
77894	4-19	400
77906	4-32	40
77907	4-32	40
77908	4-32	40
77912	4-32	40
77930	4-19	400
77932	4-19	400
77934	4-19	400
77935	4-19	400
77936	4-19	400

Core Locator & Unit Pack Quantity

XFLUX[®] (Toroids)

P/N	PAGE	QTY
78051	4-13	5,000
78059	4-17	1,000
78071	4-20	250
78076	4-22	220
78083	4-23	180
78090	4-25	120

P/N	PAGE	QTY
78110	4-28	90
78121	4-14	2,000
78192	4-27	80
78351	4-18	480
78381	4-21	2,000
78439	4-24	105

P/N	PAGE	QTY
78586	4-21	300
78716	4-26	90
78848	4-16	1,600
78867	4-31	45
78894	4-19	400
78907	4-32	40

Powder Core Locator by Size (mm)

OD	ID	HT	MPP	High Flux	Kool M μ [®]	XFlux [®]
3.56	1.78	1.52	55140	-	77140	-
			55139	-	77141	-
			55138	-	77444	-
			55134	-	77445	-
			55137	-	-	-
			55135	-	-	-
140 SIZE PAGE 4-1						
3.94	2.24	2.54	55150	-	77151	-
			55149	-	77155	-
			55148	-	77154	-
			55144	-	77150	-
			55147	-	-	-
			55145	-	-	-
150 SIZE PAGE 4-2						
4.65	2.36	2.54	55181	-	77181	-
			55180	-	77185	-
			55179	-	77184	-
			55178	-	77180	-
			55174	-	-	-
			55177	-	-	-
			55175	-	-	-
180 SIZE PAGE 4-3						
6.35	2.79	2.79	55023	58023	77021	-
			55022	58022	77825	-
			55021	58021	77824	-
			55020	58020	77020	-
			55019	58019	-	-
			55018	58018	-	-
			55014	-	-	-
			55017	-	-	-
			55015	-	-	-
			55016	-	-	-
020 SIZE PAGE 4-4						
6.6	2.67	2.54	55243	58243	77241	-
			55242	58242	77245	-
			55241	58241	77244	-
			55240	58240	77240	-
			55239	58239	-	-
			55238	58238	-	-
			55234	-	-	-
			55237	-	-	-
			55235	-	-	-
			55236	-	-	-
240 SIZE PAGE 4-5						
6.6	2.67	4.78	55273	58273	77271	-
			55272	58272	77875	-
			55271	58271	77874	-
			55270	58270	77270	-
			55269	58269	-	-
			55268	58268	-	-
			55264	-	-	-
			55267	-	-	-
			55265	-	-	-
			55266	-	-	-
			270 SIZE PAGE 4-6			
6.86	3.96	5.08	55413	58413	77411	-
			55412	58412	77415	-
			55411	58411	77414	-
			55410	58410	77410	-
			55409	58409	-	-
			55408	58408	-	-
			55404	-	-	-
			55407	-	-	-
			55405	-	-	-
			410 SIZE PAGE 4-7			
7.87	3.96	3.18	55033	58033	77031	-
			55032	58032	77035	-
			55031	58031	77034	-
			55030	58030	77030	-
			55029	58029	-	-
			55028	58028	-	-
			55024	58024	-	-
			55027	-	-	-
			55026	-	-	-
			55025	-	-	-
			030 SIZE PAGE 4-8			

OD	ID	HT	MPP	High Flux	Kool M μ [®]	XFlux [®]
9.65	4.78	3.18	55283	58283	77281	-
			55282	58282	77885	-
			55281	58281	77884	-
			55280	58280	77280	-
			55279	58279	-	-
			55278	55278	-	-
			55274	-	-	-
			55277	-	-	-
			55276	-	-	-
			55275	-	-	-
			280 SIZE PAGE 4-9			
9.65	4.78	3.96	55293	58293	77291	-
			55292	58292	77295	-
			55291	58291	77294	-
			55290	58290	77290	-
			55289	58289	-	-
			55288	55288	-	-
			55284	-	-	-
			55287	-	-	-
			55285	-	-	-
55286	-	-	-			
290 SIZE PAGE 4-10						
10.2	5.08	3.96	55043	58043	77041	-
			55042	58042	77845	-
			55041	58041	77844	-
			55040	58040	77040	-
			55039	58039	-	-
			55038	58038	-	-
			55034	-	-	-
			55037	-	-	-
			55035	-	-	-
			55036	-	-	-
040 SIZE PAGE 4-11						
11.2	6.35	3.96	55133	58133	77131	-
			55132	58132	77335	-
			55131	58131	77334	-
			55130	58130	77130	-
			55129	58129	-	-
			55128	58128	-	-
			55124	-	-	-
			55127	-	-	-
			55125	-	-	-
130 SIZE PAGE 4-12						
12.7	7.62	4.75	55053	58053	77051	78051
			55052	58052	77055	-
			55051	58051	77054	-
			55050	58050	77050	-
			55049	58049	-	-
			55048	58048	-	-
			55044	-	-	-
			55047	-	-	-
			55045	-	-	-
			55046	-	-	-
			050 SIZE PAGE 4-13			
16.6	10.2	6.35	55123	58123	77121	78121
			55122	58122	77225	-
			55121	58121	77224	-
			55120	58120	77120	-
			55119	58119	-	-
			55118	58118	-	-
			55114	-	-	-
			55117	-	-	-
			55115	-	-	-
			55116	-	-	-
120 SIZE PAGE 4-14						
17.3	9.65	6.35	55383	58383	77381	78381
			55382	58382	77385	-
			55381	58381	77384	-
			55380	58380	77380	-
			55379	58379	-	-
			55378	58378	-	-
			55374	-	-	-
			55377	-	-	-
			55375	-	-	-
			380 SIZE PAGE 4-15			

The tool set for each size of core can be used to make a full range of materials and permeabilities. Magnetics denotes each tool set by the 125 μ core made with it. Exception OD > 4"

Powder Core Locator by Size (mm)

OD	ID	HT	MPP	High Flux	Kool M μ [®]	XFLUX [®]			
20.3	12.7	6.35	55209	58209	77847	78848			
			55208	58208	77848	-			
			55848	58848	77211	-			
			55206	58206	77210	-			
			55205	58205	77206	-			
			55204	58204	-	-			
			55200	-	-	-			
			55203	-	-	-			
			55201	-	-	-			
			55202	-	-	-			
			22.9	14.0	7.62	55313	58313	77312	78059
55312	58312	77316				-			
55059	58059	77059				-			
55310	58310	77315				-			
55309	58309	77314				-			
55308	58308	77310				-			
55304	-	-				-			
55307	-	-				-			
55305	-	-				-			
55306	-	-				-			
23.6	14.4	8.89				55353	58353	77352	78351
			55352	58352	77356	-			
			55351	58351	77351	-			
			55350	58350	77355	-			
			55349	58349	77354	-			
			55348	58348	77350	-			
			55344	-	-	-			
			55347	-	-	-			
			55345	-	-	-			
			26.9	14.7	11.2	55933	58933	77932	78894
						55932	58932	77936	-
55894	58894	77894				-			
55930	58930	77935				-			
55929	58929	77934				-			
55928	58928	77930				-			
55924	-	-				-			
55927	-	-				-			
55925	-	-				-			
55926	-	-				-			
32.8	20.1	10.7				55551	58551	77550	78071
			55550	58550	77555	-			
			55071	58071	77071	-			
			55548	58548	77553	-			
			55547	58547	77552	-			
			55546	58546	77548	-			
			55542	-	-	-			
			55545	-	-	-			
			55543	-	-	-			
			55544	-	-	-			
			34.3	23.4	8.89	55588	58588	77587	78586
55587	58587	77591				-			
55586	58586	77586				-			
55585	58585	77590				-			
55584	58584	77589				-			
55583	58583	77585				-			
55579	-	-				-			
55582	-	-				-			
55580	-	-				-			
55581	-	-				-			
35.8	22.4	10.5				55327	58327	77326	78076
			55326	58326	77330	-			
			55076	58076	77076	-			
			55324	58324	77329	-			
			55323	58323	77328	-			
			55322	58322	77324	-			
			55318	-	-	-			
			55321	-	-	-			
			55319	-	-	-			
			55320	-	-	-			

OD	ID	HT	MPP	High Flux	Kool M μ [®]	XFLUX [®]			
39.9	24.1	14.5	55257	58257	77256	78083			
			55256	58256	77260	-			
			55083	58083	77083	-			
			55254	58254	77259	-			
			55253	58253	77258	-			
			55252	58252	77254	-			
			55248	-	-	-			
			55251	-	-	-			
			55249	-	-	-			
			55250	-	-	-			
			46.7	24.1	18.0	55441	58441	77440	78439
55440	58440	77431				-			
55439	58439	77439				-			
55438	58438	77443				-			
55437	58437	77442				-			
55436	-	77438				-			
55432	-	-				-			
55435	-	-				-			
55433	-	-				-			
46.7	28.7	15.2				55092	58092	77091	78090
						55091	58091	77095	-
			55090	58090	77090	-			
			55089	58089	77094	-			
			55088	-	77093	-			
			55087	-	77089	-			
			55082	-	-	-			
			55086	-	-	-			
			55084	-	-	-			
			50.8	31.8	13.5	55718	58718	77717	78716
						55717	58717	77721	-
55716	58716	77716				-			
55715	58715	77720				-			
55714	58714	77719				-			
55713	-	77715				-			
55709	-	-				-			
55712	-	-				-			
55710	-	-				-			
57.2	26.4	15.2				55190	58190	77191	78192
						55191	58191	77189	-
			55192	58192	77192	-			
			55195	58195	77193	-			
			55196	-	77194	-			
			55197	-	77195	-			
			55198	-	-	-			
			55199	-	-	-			
			57.2	35.6	14.0	55112	58112	77111	78110
						55111	58111	77212	-
						55110	58110	77110	-
55109	58109	77214				-			
55108	-	77213				-			
55107	-	77109				-			
55103	-	-				-			
55106	-	-				-			
55104	-	-				-			
62.0	32.6	25.0				55614	58614	77615	-
						55615	58615	77616	-
			55617	58617	77617	-			
			55620	58620	77618	-			
			-	-	77619	-			
			74.1	45.3	35.0	55734	58734	77735	-
						55735	58735	77736	-
						55737	58737	77737	-
						55740	58740	77738	-
						-	-	77739	-

Core Locator by Size Table continued...



The tool set for each size of core can be used to make a full range of materials and permeabilities. Magnetics denotes each tool set by the 125 μ core made with it. Exception OD > 4"

Powder Core Locator by Size (mm)

OD	ID	HT	MPP	High Flux	Kool M μ [®]	XFlux [®]
77.8	49.2	12.7	55869	58869	77868	78867
866 SIZE PAGE 4-31			55868	58868	77872	-
			55867	58867	77867	-
			55866	58866	-	-
77.8	49.2	15.9	55909	58909	77908	78907
906 SIZE PAGE 4-32			55908	58908	77912	-
			55907	58907	77907	-
			55906	58906	77906	-
101.6	57.2	16.5	55101	58101	77102	-
102 SIZE PAGE 4-33			55102	58102	77100	-
			55099	58099	77099	-
			55098	58098	77098	-

OD	ID	HT	MPP	High Flux	Kool M μ [®]	XFlux [®]
132.6	78.6	25.4	55336	58336	77337	-
337 SIZE PAGE 4-34			55337	58337	77338	-
			55339	58339	77339	-
			55340	58340	-	-
165.1	102.4	31.7	55164	58164	77165	-
165 SIZE PAGE 4-35			55165	58165	77166	-
			55167	58167	-	-

The tool set for each size of core can be used to make a full range of materials and permeabilities. Magnetics denotes each tool set by the 125 μ core made with it. Exception OD > 4"

Introduction

Magnetics Molypermalloy Powder (MPP) cores are distributed air gap toroidal cores made from a 81% nickel, 17% iron, and 2% molybdenum alloy powder for the lowest core losses of any powder core material. MPP cores (and all powder cores) exhibit soft saturation, which is a significant design advantage compared with gapped ferrites. Also, unlike ferrites, the MPP saturation curve does not need to be derated with increasing device temperature.

MPP cores possess many outstanding magnetic characteristics, such as high resistivity, low hysteresis and eddy current losses, excellent inductance stability after high DC magnetization or under high DC bias conditions and minimal inductance shift under high AC excitation.

MPP THINZ®, or washer cores, put the premium performance of Magnetics' superior MPP material into robust, low height toroid form, for low profile inductors. With MPP THINZ, exact permeability and height are easily adjusted to result in the optimum design for each application.

Magnetics High Flux powder cores are distributed air gap toroidal cores made from a 50% nickel - 50% iron alloy powder for the highest biasing capability of any powder core material. High Flux cores have advantages that result in superior performance in certain applications involving high power, high DC bias, or high AC excitation amplitude. The High Flux alloy has saturation flux density that is twice that of MPP alloy, and three times or more than that of ferrite. As a consequence, High Flux cores can support significantly more DC Bias current or AC flux density.

High Flux offers much lower core losses and superior DC bias compared with powdered iron cores. High Flux cores offer lower core losses and similar DC bias compared with XF_{LUX} cores.

Frequently, High Flux allows the designer to reduce the size of an inductive component compared with MPP, powdered iron, or ferrite.

Magnetics Kool M μ ® powder cores are distributed air gap cores made from a ferrous alloy powder for low losses at elevated frequencies. The near zero magnetostriction alloy makes Kool M μ ideal for eliminating audible frequency noise in filter inductors. In high frequency applications, core losses of powdered iron, for instance, can be a major factor in contributing to undesirable temperature rises. Kool M μ cores are superior because their losses are significantly less, resulting in lower temperature rises. Kool M μ cores generally offer a reduction in core size, or an improvement in efficiency, compared with powdered iron cores.

Inductors built with Kool M μ cores do not have several of the disadvantages that are inherent with gapped ferrite cores:

1. Ferrite saturation flux density is 0.5T or less, which is less than half of the flux density of Kool M μ alloy. This results in much less energy storage possible in the same volume with ferrite.
2. Moreover, saturation flux density in ferrites is reduced significantly at elevated temperatures, but in Kool M μ it is not.
3. Ferrites exhibit sharp saturation, and thus risk complete collapse of inductance above a certain safe current level. Kool M μ 's saturation is soft, allowing for safe design to much higher currents.
4. Fringing losses at the discrete air gap in a ferrite inductor can be disastrous, a problem that is completely absent with Kool M μ .

Kool M μ is available in a variety of core types, for maximum flexibility. Toroids offer compact size and self-shielding. E cores and U cores afford lower cost of winding, use of foil inductors, and ease of fixturing. Very large cores and structures are available to support very high current applications. These include toroids and racetrack shapes up to 102 mm, 133 mm and 165 mm; jumbo E cores; stacked shapes; and blocks.

Magnetics XF_{LUX}® distributed air gap cores are made from 6.5% silicon iron powder. A true high temperature material, with no thermal aging, XF_{LUX} offers lower losses than powdered iron cores and superior DC bias performance. The soft saturation of XF_{LUX} material offers an advantage over ferrite cores. XF_{LUX} cores are ideal for low and medium frequency chokes where inductance at peak load is critical.

Applications

Magnetics powder cores are most commonly used in power inductor applications, specifically in switch-mode power supply (SMPS), filter inductors, also known as DC inductors, or chokes. Other Power applications include differential inductors, boost inductors, buck inductors and flyback transformers.

While all four materials are used in these applications, each has its own advantage. For the lowest loss inductor, MPP material should be used since it has the lowest core loss. For the smallest core size in a DC bias dominated design,

High Flux material should be used since it has the highest flux capacity. XFLux® can be a lower cost alternative to High Flux, in situations where the higher core losses and more limited permeability availability of XFLux is acceptable.

The unique advantages of Magnetics' powder cores are used in a variety of other applications, including: High Q filters, temperature stabilized filters and inductors, high reliability inductors and filters, high temperature inductors and filters, high current current transformers, telecom filters and load coils.

	MPP	High Flux	Kool M μ ®	XFLux®
Permeability	14-550	14-160	26-125	60
Core Loss	Lowest	Moderate	Low	High
Perm vs. DC Bias	Better	Best	Good	Best
Temperature Stability	Best	Very Good	Very Good	Good
Temperature Rating	200° C continuous	200° C continuous	200° C continuous	200° C continuous
Saturation Characteristic	Soft	Soft	Soft	Soft
Nickel Content	81%	50%	0%	0%
Relative Cost	High	Medium	Low	Low

A lower cost family of alternative products to Magnetics' four premium powder core materials are powdered irons. Manufacturers of powdered iron use a different production process. For comparison with the above table, powdered irons have permeabilities from 10 -100; highest core loss; good perm vs. DC bias; fair temperature stability; lower temperature ratings; soft saturation; 0% nickel content; lowest relative cost.

Core Identification

All Magnetics powder cores have unique part numbers that provide important information about the characteristics of the cores. A description of each type of part number is provided below.

TOROIDS

C055206A2

Core Finish Code	Voltage Breakdown*	Material Availability	OD Size Availability	Permeability Availability
A2	1,000 volts min	MPP, High Flux	All	All
A7	1,000 volts min	Kool M μ [®] , XFLux [®]	All	All
AY	600 volts min	All	3.56 - 16.5 mm	14 μ - 300 μ
A5	2,000 volts min	MPP, High Flux	>4.65 mm	All
A9	8,000 volts min	MPP, High Flux	>4.65 mm	All
D4	1,000 volts min	MPP	>4.65 mm	60 μ - 200 μ
W4	1,000 volts min	MPP	>4.65 mm	60 μ - 200 μ
M4	1,000 volts min	MPP	>4.65 mm	60 μ - 200 μ
L6	1,000 volts min	MPP	>4.65 mm	60 μ - 300 μ

* No voltage breakdown min for A2 or A7 with OD \leq 4.65mm

Catalog Number (designates size and permeability)

Material Code 55 = MPP
58 = High Flux
77 = Kool M μ
78 = XFLux

Grading Code CO = Graded into 2% inductance bands – OD <5 mm, 5% bands
OO = Not graded

Powder Core Toroid Stamping Summary

Size (O.D. mm)	6-digit Shop Order Number	2-digit Material Code	3-digit Catalog Number	2-digit Core Finish Code	Inductance Code	Inductance Example
6.35 - 6.86	✓		✓		✓	123456 020 +6
7.87 - 12.7	✓		✓	✓	✓	123456 050A2 +6
> 12.7	✓	✓	✓	✓	✓	123456 55120A2 +6

- Inductance Code is only stamped on MPP toroids with CO Grading Code
- Cores with O.D. less than 6.35 mm are not stamped

- Shop order number identifies the product batch, ensuring traceability of every core through the entire manufacturing process, back to raw materials

E CORES and THINZ

00K5528E060

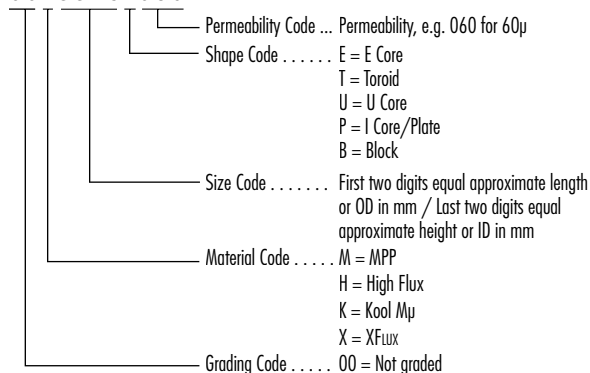

LARGE E CORES and SEGMENTS

00K130LE026

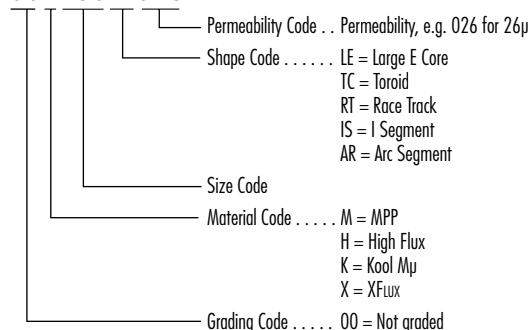

- Full part number and shop order number are stamped on all shapes



Core Coating

Magnetics toroidal powder cores are coated with a special epoxy finish that provides a tough, wax tight, moisture and chemical resistant barrier having excellent dielectric properties. Parylene coating is also offered.

Material	Color	Core Finish Codes
MPP	Gray	A2, A5, A9, D4, M4, W4, L6
High Flux	Khaki	A2, A5, A9
Kool M μ [®]	Black	A7
XFLux [®]	Brown	A7

The finish is tested for voltage breakdown by inserting the core between two weighted wire mesh pads. Force is adjusted to produce a uniform pressure of 10 psi, simulating winding pressure. The test condition for each core in the random sample set, to guarantee minimum breakdown voltage in each production batch, is 60 Hz rms voltage at 1.25 the guaranteed limit. A2 and A7 samples are tested to 1250 V min wire-to-wire. AY samples are tested to 750 V min wire-to-wire.

Higher minimum breakdown coatings can be applied upon request for cores larger than 4.65 mm.

Toroids as large as 16.5 mm outside diameter can be coated with parylene to minimize the constriction of the inside diameter. All finished dimensions in this catalog are for epoxy coating (A2 or A7). For a parylene coated toroid (AY), the maximum OD and HT are reduced by 0.18 mm (0.007"), and the minimum ID is increased by 0.18 mm (0.007").

The maximum steady-state operating temperature for epoxy coating is 200°C. The maximum steady-state operating temperature for parylene coating is 130°C, but it can be used as high as 200°C for short periods, such as during board soldering. High temperature operation of Magnetics powder cores does not affect magnetic properties.

MPP, High Flux, Kool M μ , and XFLux materials can be operated continuously at 200°C with no aging or damage.

Core Inductance Tolerance and Grading

Magnetics powder cores are precision manufactured to an inductance tolerance of $\pm 8\%$ *, using standard Kelsall Permeameter Cup measurements and a precision series inductance bridge.

MPP and High Flux cores with outside diameters > 4.65 mm are graded into 2% inductance bands as a standard practice at no additional charge. Core grading can reduce winding costs by minimizing turns adjustments when building high turns inductors to very tight inductance specifications. MPP cores 4.65 mm and smaller are graded into 5% bands. 14 μ cores, 26 μ cores, MPP THINZ[®] and parylene coated cores are not graded.

Graded Magnetics MPP cores and High Flux cores are also available with tolerances tighter than the standard $\pm 8\%$.

*Kool M μ cores with outside diameters less than 12.7 mm have wider tolerances.

GRADE Stamped on Core OD	INDUCTANCE % Deviation from Nominal		TURNS % Deviation from Nominal	
	From	To	From	To
+8	+8	+7	-4.0	-3.5
+6	+7	+5	-3.5	-2.5
+4	+5	+3	-2.5	-1.5
+2	+3	+1	-1.5	-0.5
+0	+1	-1	-0.5	+0.5
-2	-1	-3	+0.5	+1.5
-4	-3	-5	+1.5	+2.5
-6	-5	-7	+2.5	+3.5
-8	-7	-8	+3.5	+4.0

A_L and Inductance Calculation

The nominal inductance of a wound core can be calculated from the core geometry by using the following equation:

$$L = \frac{.4\pi\mu N^2 A_c}{l_c 10^3}$$

where:

- L = inductance (μH)
- μ = core permeability
- N = number of turns
- A_c = core cross section (mm^2)
- l_c = core magnetic path length (mm)

The inductance for a given number of turns is related to the inductance factor listed in the catalog by:

$$L_N = A_L N^2 10^{-3}$$

where:

- L_N = inductance for N turns (μH)
- A_L = inductance factor (nH/T^2)
- N = number of turns

Measured vs. Calculated Inductance

Magnetics inductance standards are measured in a Kelsall Permeameter Cup. Actual wound inductance measured outside a Kelsall Cup is greater than the nominal calculated value due to leakage flux and flux developed by the current in the winding. The difference depends on many variables; core size, permeability, core coating thickness, wire size and number of turns, in addition to the way in which the windings are put on the core. The difference is negligible for permeabilities above 125 and turns greater than 500. However, the lower the permeability and/or number of turns, the more pronounced this deviation becomes.

Example : C055930A2 (26.9 mm, 125 μ)

Number of Turns	Calculated Inductance	Measured Inductance
1,000	157 mH	+0.0%
500	39.3 mH	+0.5%
300	14.1 mH	+1%
100	1.57 mH	+3%
50	393 μH	+5%
25	98.1 μH	+9%

The following formula can be used to approximate the leakage flux to add to the expected inductance. This formula was developed from historical data of cores tested at Magnetics. Be aware that this will only give an approximation based on evenly spaced windings. You may expect as much as a $\pm 50\%$ deviation from this result.

$$L_{LK} = \frac{0.292 N^{1.065} A_c}{l_c}$$

where:

- L_{LK} = leakage inductance adder (μH)
- N = number of turns
- A_c = core cross section (mm^2)
- l_c = core magnetic path length (mm)

Example C055930A2 with 25 turns (p. 4-19)

Catalog Data	Calculated Inductance	Leakage Adder	Estimated Measured Inductance
$A_L = 157 \text{ nH}/\text{T}^2$	$L_N = (157)(25)^2 10^{-3}$	$L_{LK} = \frac{0.292(25)^{1.065}(65.4)}{63.5}$	$L = L_N + L_{LK}$
$A_c = 65.4 \text{ mm}^2$	$= 98.1 \mu\text{H}$	$= 9.3 \mu\text{H}$	$= 98.1 + 9.3$
$l_c = 63.5 \text{ mm}$			$= 107 \mu\text{H}$

MPP Temperature Stabilization

Magnetics MPP cores are provided in three basic temperature stabilizations: Standard, Controlled and Linear.

The core finish code is used to designate the stabilization, although the coating itself has no influence on the temperature stabilization performance of the core. A2, A7, AY, A5 and A9 are standard; D4, W4, and M4 are controlled stabilization, and L6 is linear stabilization. See page 1-3 for size and permeability availability.

Inductance of standard MPP cores exhibits a small, positive temperature coefficient. This is due to the permeability vs. temperature characteristic of the magnetic alloy, and to the thermal expansion response of the distributed air gap formed by the insulating material surrounding metal powder grains.

The inductance of controlled stabilization MPP cores (codes D4, W4 and M4) exhibits nearly flat temperature coefficient within defined temperature ranges. This is accomplished with adjustments in the alloy chemistry, unique to Magnetics. Cost is higher than for standard cores, but there is no

impact on any electrical or physical properties apart from the flattened inductance curve.

The typical applications for stabilized cores are tuned filters, where very consistent inductance over temperature is required. The flat inductance performance of controlled stabilization cores is apparent only at low drive levels, less than 10 mT. Consequently, there is no performance benefit to using stabilized cores at higher drive levels, for example in power chokes.

L6 code, linear stabilization, was originally developed to match the temperature coefficient of polystyrene capacitors, permitting the design of passive filters that are very stable over a wide temperature range, even though the capacitors shift.

Initial inductance and initial inductance stability are sensitive to external factors such as moisture and physical stress. See Precision Inductor Processing on page 1-7.

Part Number Suffix	Stabilization Type	Guaranteed Inductance Stability Limits	Stabilized Temperature Range
D4	Controlled	±0.1%	0° to +55°C
W4	Controlled	±.25%	-55°C to +85°C
M4	Controlled	±.25%	-65°C to +125°C
L6	Linear	+25 to +90 ppm/°C +65 to +150 ppm/°C	-55°C to +25°C +25°C to +85°C
L6	Linear (300µ)	+25 to +110 ppm/°C +65 to +180 ppm/°C	-55°C to +25°C +25°C to +85°C

M4 cores meet the W4 limits and may be substituted in place of W4.

Stability limit example: When the 2mT, 10kHz inductance of a W4 stabilized core is measured at all temperature stops between -55°C and +85°C, the difference between the highest value and the lowest value cannot exceed 0.50% of the inductance at 25°C. L6 ppm slopes are referenced to 25°C.

Precision Inductor Processing

Magnetics MPP cores possess excellent stability. Under typical shelf life conditions the initial inductance of an unpotted core will shift less than 0.5%.

If maximum stability is desired, the following procedures will remove physical stresses and core moisture, leading to inductance stabilities better than 0.05%

The application where these precautions are used is typically high turns precision filter inductors, operating at low drive levels. Power inductors would see no benefit, as they do not operate near the initial permeability of the core, nor do they generally require the same precision.

1. Wind cores to the approximate specified inductance (slightly over the desired value).
2. Cool wound cores to -60°C. Maintain at temperature for 20 minutes to help relieve winding stresses caused by high winding tension, large wire, or many turns.
3. Heat cores slowly (<2°C/minute) to 115°C. Maintain at temperature for 20 minutes.
4. Steps 2 and 3 should be repeated twice.
5. Bake at 115°C for 16 hours.
6. Cool to room temperature and adjust turns to obtain specified inductance.
7. Cores must be kept dry until potted or hermetically sealed.
8. If the cores are to be potted, they should be covered first with cushioning material, such as silicone rubber. This material minimizes the possibility of the potting compound stressing the core and changing the inductance value.
9. Potting compounds should be chosen with care, as even semi-flexible resins can cause core stresses and reduce stability. Selection should be based on minimum shrinkage and minimum moisture absorption.

Inductor Core Selection Procedure

Only two parameters of the design application must be known to select a core for a current-limited inductor; inductance required with DC bias and the DC current. Use the following procedure to determine the core size and number of turns.

1. Compute the product of LI^2 where:
 L = inductance required with DC bias (mH)
 I = DC current (A)
2. Locate the LI^2 value on the Core Selector Chart (page 2-3, 2-4, & 2-5). Follow this coordinate to the intersection with the first core size that lies above the diagonal permeability line. This is the smallest core size that can be used.
3. The permeability line is sectioned into standard available core permeabilities. Selecting the permeability indicated will tend to be the best trade-off between A_L and DC bias.
4. Inductance, core size, and permeability are now known. Calculate the number of turns by using the following procedure:
 - (a) The inductance factor (A_L in nH/T^2) for the core is obtained from the core data sheet. Determine the minimum A_L by using the worst case negative tolerance (generally -8%). With this information, calculate the number of turns needed to obtain the required inductance from:

$$N = \sqrt{\frac{L \cdot 10^3}{A_L}}$$
 Where L is required inductance (μH)
 - (b) Calculate the bias in A-T/cm from:

$$H = \frac{NI}{l_e}$$
 - (c) From the Permeability vs. DC Bias curves (pages 3-18 through 3-20 & 4-39 through 4-41), determine the rolloff in per unit of initial permeability for the previously calculated bias level. Curve fit equations shown in the catalog can simplify this step.
 - (d) Multiply the required inductance by the per unit rolloff to find the inductance with bias current applied.
 - (e) Increase the number of turns by dividing the initial number of turns (from step 4(a)) by the per unit initial value of permeability. This will yield an inductance close to the required value after steps 4 (b), (c) and (d) are repeated.
 - (f) Iterate steps 4 (b), (c) and (d) if needed to adjust biased inductance up or down until it is satisfactorily close to the target.
5. Choose the correct wire size using the Wire Table (page 3-28). Duty cycles below 100% allow smaller wire sizes and lower winding factors, but do not allow smaller core sizes.
6. To calculate winding factor, multiply the number of turns by the wire area found on page 3-28 to find the total wire area. Divide the total wire area by the core window area to obtain the winding factor of the design. Verify that the winding factor is acceptable by referencing the various winding approaches described on page 2-7.
7. If a significant ripple current will be present, estimate the core losses using the Core Loss Calculation procedure on pages 2-8 through 2-13. If AC core losses will result in too much heating, or efficiency below requirements, then the inductor may be loss-limited rather than saturation-limited. Design options for this core are to consider a larger core, a lower permeability material, a lower loss material or some combination of these three.

Core Selection Example

Determine core size and number of turns to meet the following requirement:

- (a) Minimum inductance with DC bias of 0.6 mH (600 μ H)
- (b) DC current of 5.0 A

1. $LI^2 = 0.6 \times 5.0^2 = 15.0 \text{ mH} \cdot \text{A}^2$
2. Using the Kool M μ LI^2 chart found on page 2-4, locate 15 mH \cdot A² on the bottom axis. Following this coordinate vertically results in the selection of 0077083A7 as an appropriate core for the above requirements.
3. From the 0077083A7 core data page (4-23), the inductance factor (A_L) of this core is 81 nH/T² \pm 8%. The minimum A_L of this core is 74.6 nH/T².
4. The number of turns needed to obtain 600 μ H at no load is 90 turns. To calculate the number of turns required at full load, determine the DC Bias level: $H = N/I_e = \text{A} \cdot \text{T/cm}$ where I_e is the path length in cm. The DC bias is 45.7 A \cdot T/cm, yielding 69% of initial permeability. The adjusted turns are $\frac{90}{0.69} = 131$ Turns.
5. Re-calculate the DC bias level in A \cdot T/cm: The permeability versus DC bias curve shows 54% of initial permeability at 66.6 A \cdot T/cm.
6. Multiply the minimum A_L 74.6 nH/T² by 0.54 to yield effective $A_L = 40.3$ nH/T². The inductance of this core with 131 turns and with 66.6 A \cdot T/cm will be 691 μ H minimum. The minimum inductance requirement of 600 μ H has been achieved with full DC bias.
7. The wire table indicates that 17 AWG is needed to carry 5.0 A with a current carrying capacity of 500 A/cm². 131 turns of 17 AWG (wire area = 1.177 mm²) equals a total wire area of 154.2 mm². The window area of a 0077083A7 is 427 mm². Calculating window fill, 154.2 mm²/427 mm² corresponds to an approximate 36% winding factor. A 0077083A7 with 131 turns of 17 AWG will meet the all requirements for this inductor.

Core Selector Charts

The core selector charts are a quick guide to finding the optimum permeability and smallest core size for DC bias applications. These charts are based on a permeability reduction of not more than 50% with DC bias, typical winding factors of 40% for toroids and 60% for shapes, and an AC current that is small relative to the DC current. These charts are based on the nominal core inductance and a current density 500-600 A/cm².

If a core is being selected for use with a large AC current relative to any DC current, such as a flyback inductor or buck/boost inductor, frequently a larger core will be needed to limit the core losses due to AC flux. In other words, the design becomes loss-limited rather than bias-limited.

For additional power handling capability, stacking of cores will yield a proportional increase in power handling. For example, double stacking of the 55908 core will result doubled power handling capability to about 400 mH \cdot A².

Cores with increased heights are easily ordered. Contact Magnetics for more information.

Core Selector Charts

MPP Toroids

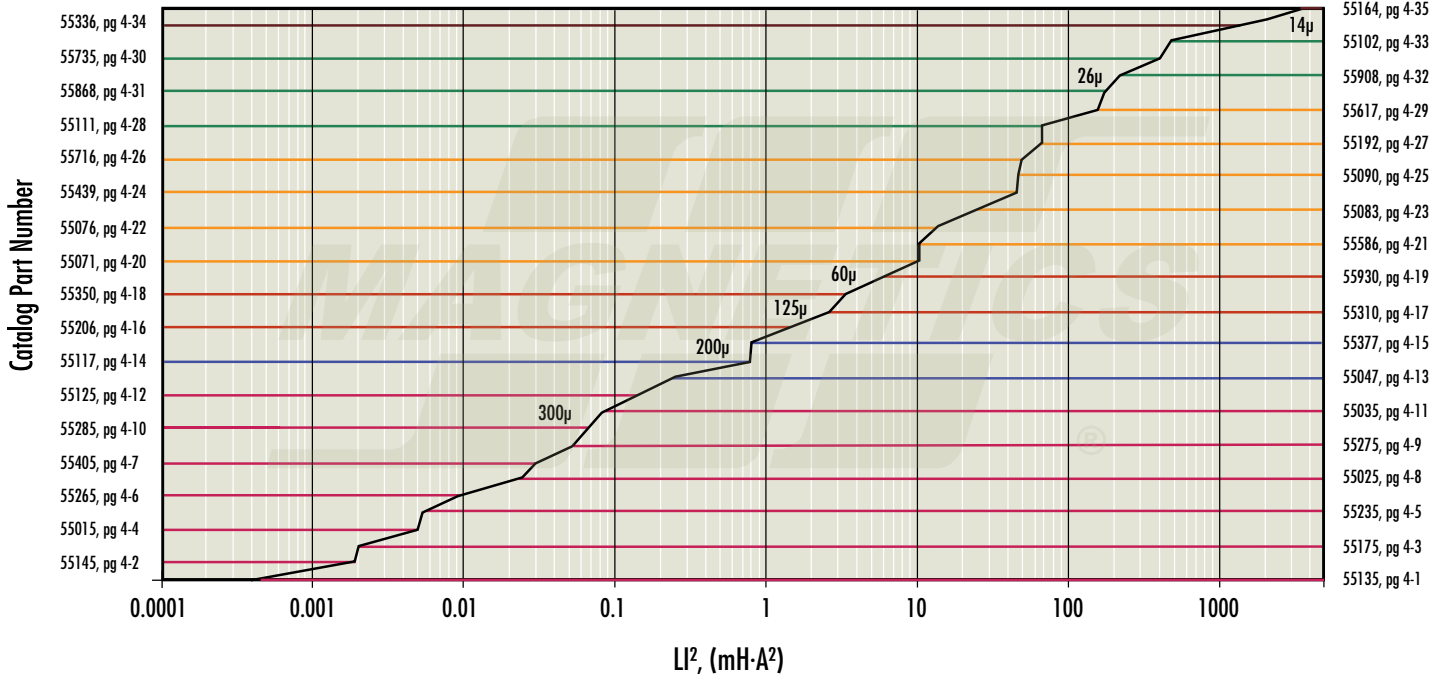

High Flux Toroids

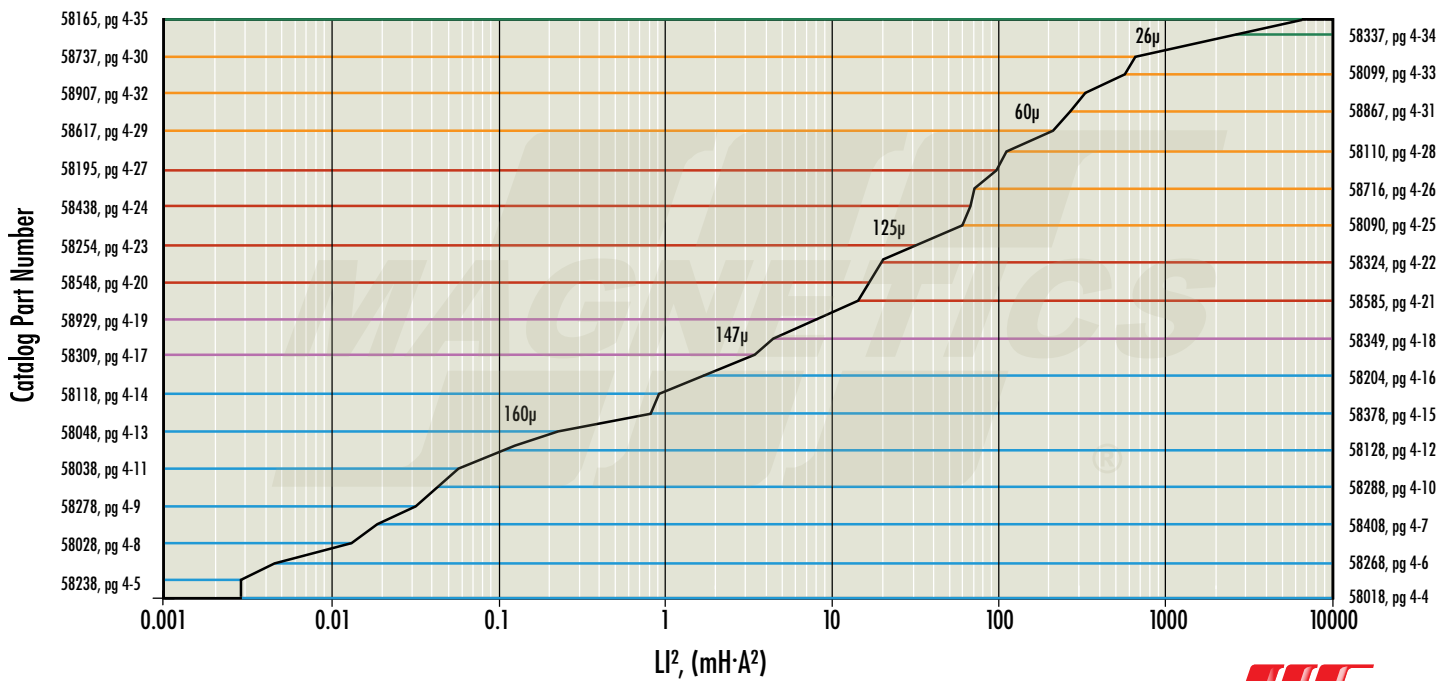

Core Selector Charts

Kool M μ [®] Toroids & Race Tracks

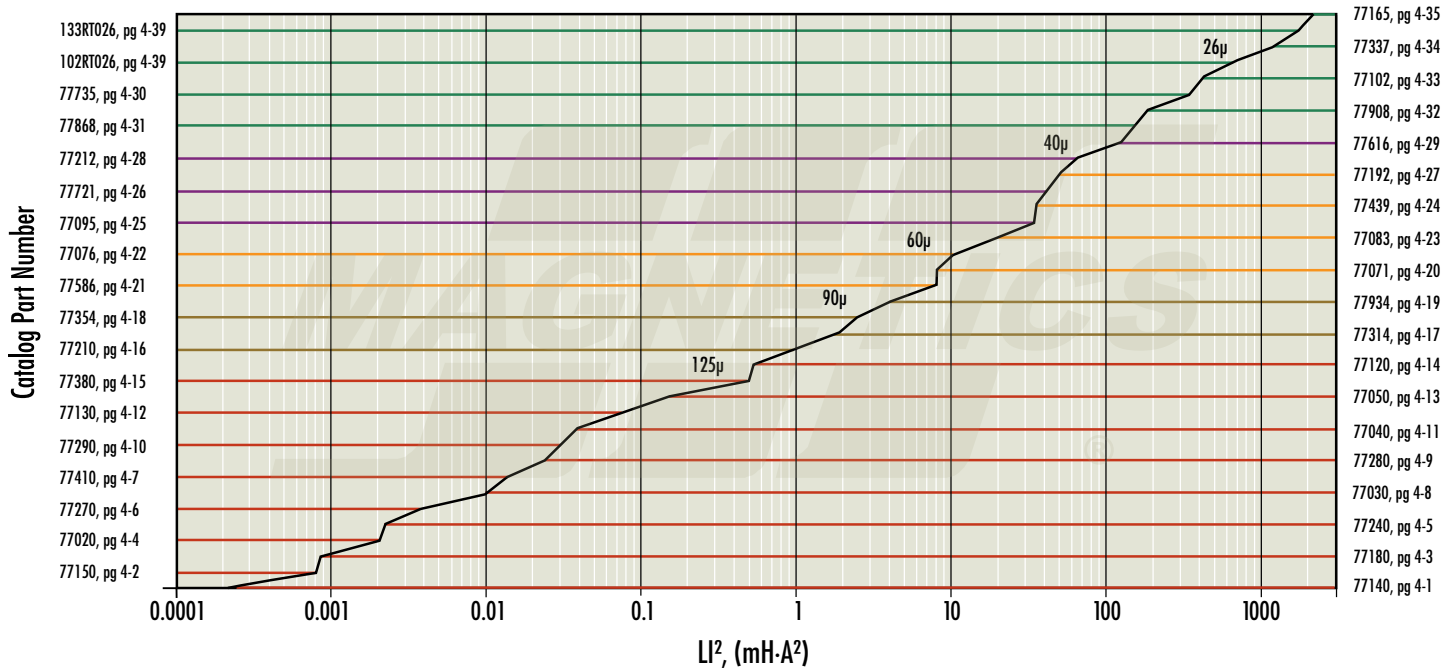

Kool M μ [®] E Cores

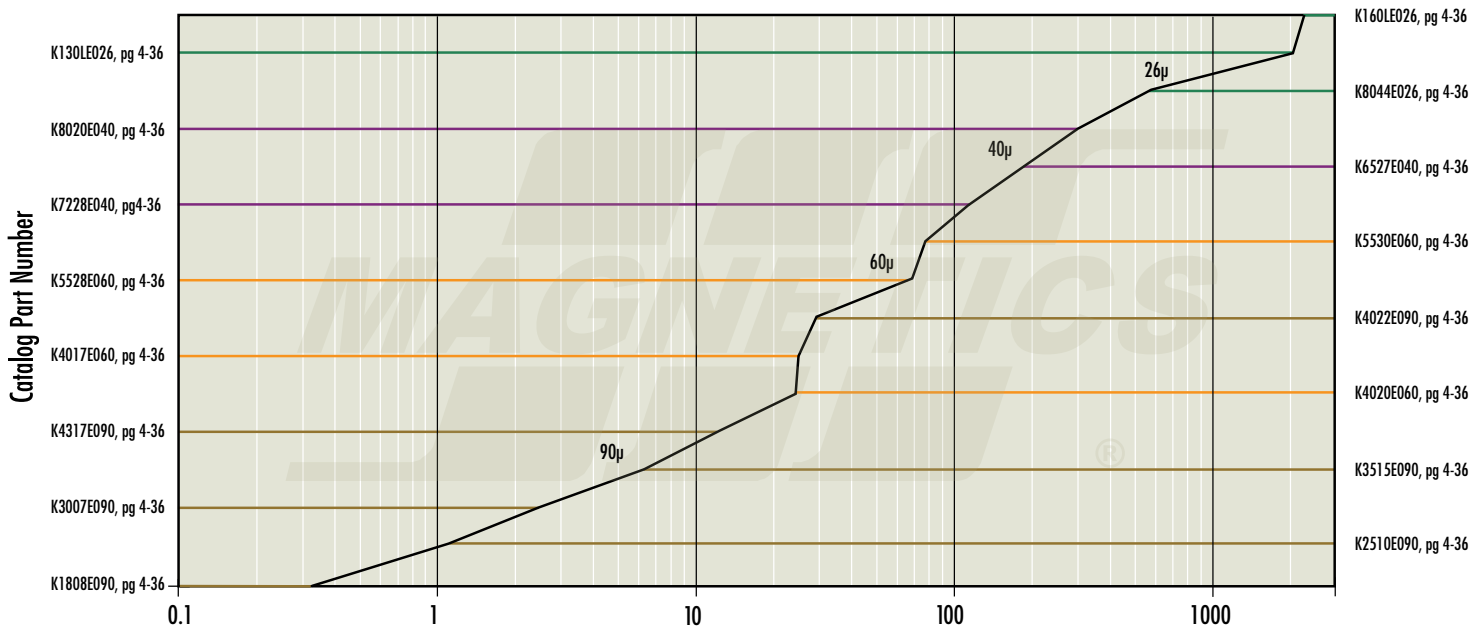

Core Selector Charts

Kool M μ [®] U Cores

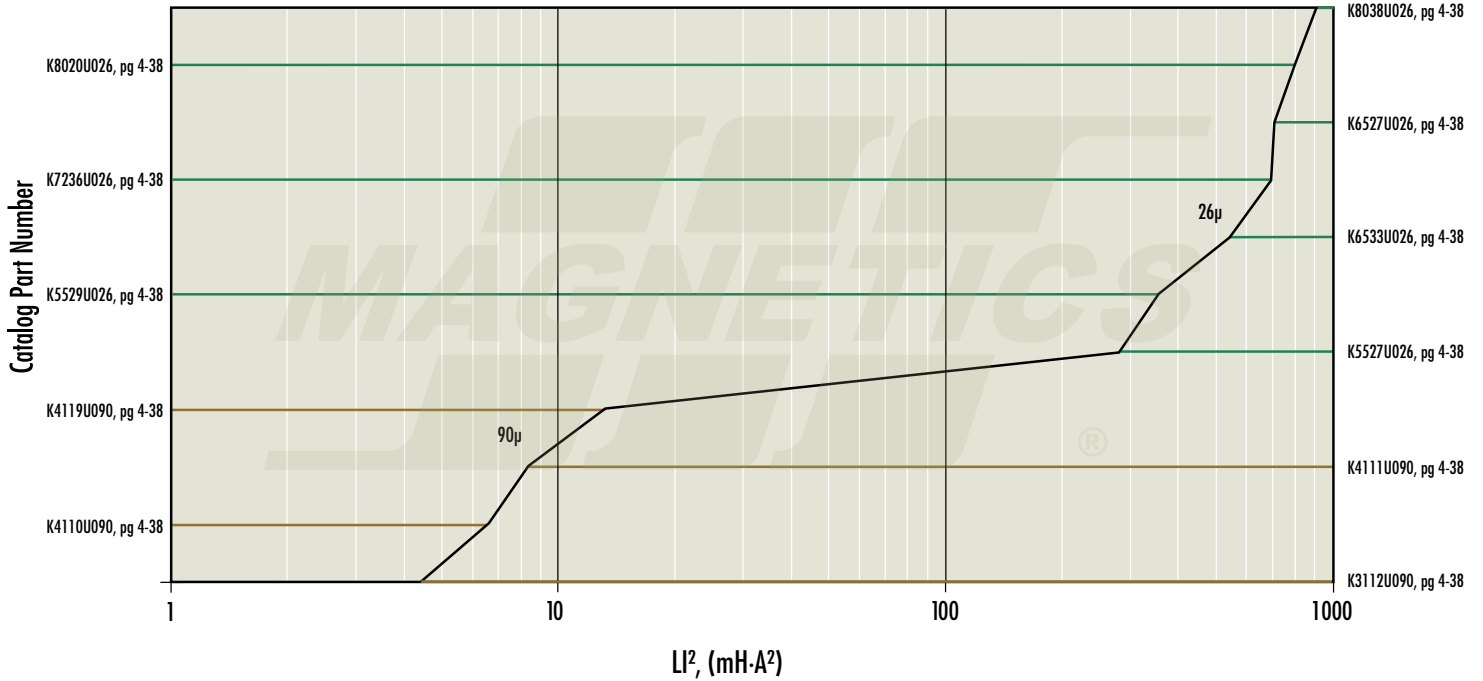

XFLUX[®] Toroids

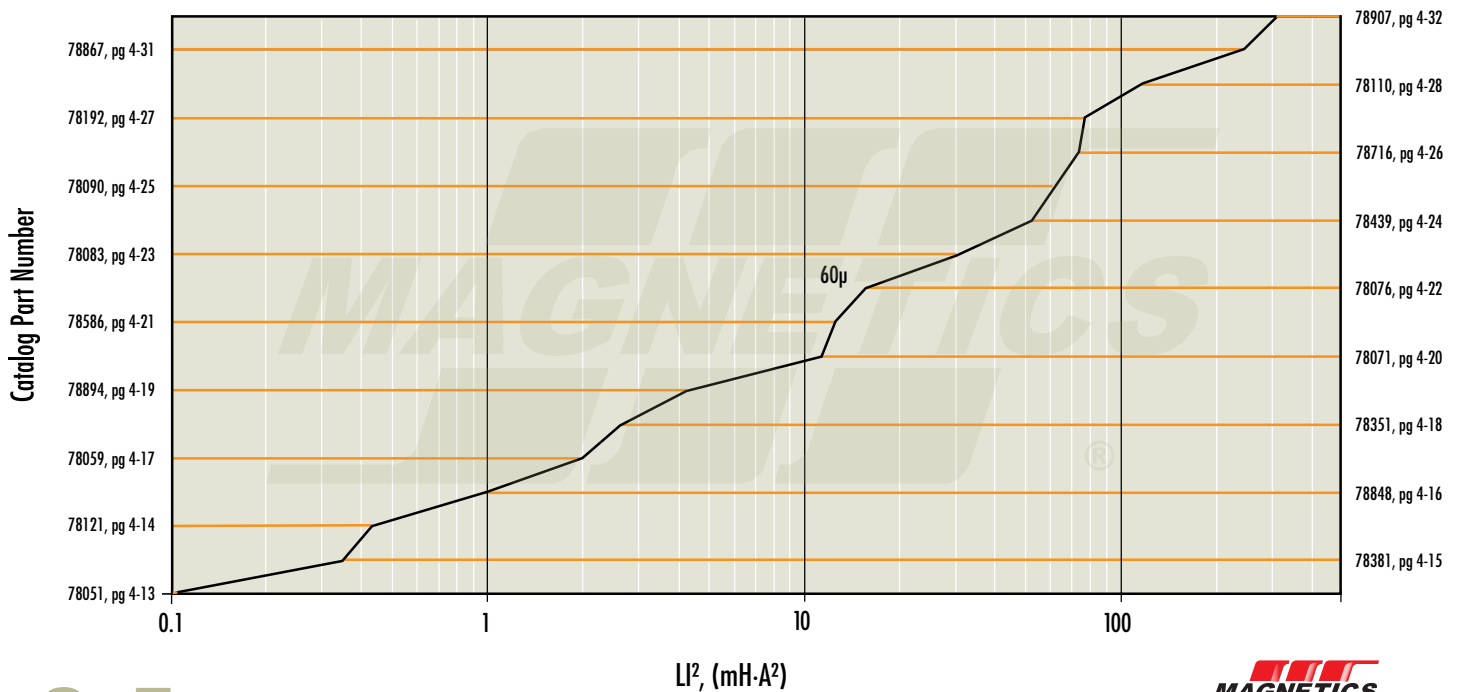

Designing With Magnetics Powder Cores

Winding Factor

Winding factor, also called fill factor, is the ratio of total conductor cross section (usually copper cross section) to the area of the core window. In other words, in a toroid, winding factor is given by:

$$\text{where: } \frac{N \cdot A_w}{W_A}$$

N = Number of turns
A_w = Area of the wire
W_A = Window Area of the core $\frac{\pi}{4} \cdot ID^2$

Toroid Core Winding factors can vary from 20-60%, a typical value in many applications being 35-40%.

In practice, several approaches to toroid winding are used:

- **Single layer:** The number of turns is limited by the inside circumference of the core divided by the wire diameter. Advantages are lower winding capacitance, more repeatable parasitics, good cooling, and low cost. Disadvantages are reduced power handling and higher flux leakage.
- **Low fill:** For manufacturing ease and reduced capacitance, winding factor between single layer and 30% may be used.
- **Full winding:** factors between 30% and 45% are normally a reasonable trade off between fully utilizing the space available for a given core size, while avoiding excessive manufacturing cost.
- **High fill:** Winding factors up to about 65% are achievable, but generally only with special expensive measures, such as completing each coil by hand after the residual hole becomes too small to fit the winding shuttle.

Mean Length of Turn

Winding turn lengths have been computed for each core size, using empirical relationships, for ten winding factors. This permits an estimate of actual length/turn for any winding factor.

MLT (Mean Length Turn) DCR Calculation

Calculating nominal DC Resistance for a single layer winding is straightforward. The mean length of turn (MLT) is simply the length of any turn along the surface of the core. MLT data can be found on each core data page. Then,

$$\text{DCR} = (\text{MLT})(N) (\Omega/\text{length of wire})$$

Even easier, Magnetics has calculated the single layer DCR for a range of wire gauges for each core size. See Winding Tables on pages 6-1 to 6-6.

Calculation Method

Calculate the winding factor for the core, wire gauge, and number of turns selected. On the wire table look up resistance per unit of length for the gauge selected.

On the data page for the core selected, consult the Winding Turn Length chart. Unless the winding factor is exactly one of the values listed, interpolate to find the MLT.

Designing With Magnetics Powder Cores

Wound Coil Dimensions

Wound coil dimensions are listed for 70% winding factor, as these are the largest dimensions necessary for packaging the wound coil. These dimensions are attainable. As a 70% winding factor (no residual hole) yields the same overall coil dimensions as a 100% (unity) winding factor (no interstices). Coil dimensions for coils wound to 40% winding factor can be estimated as follows.

where:

$$OD_{40\%} = 0.5(OD_{core} + OD_{70\%})$$

OD_{core} = core OD after finish
 $OD_{70\%}$ = wound coil OD

where:

$$HT_{40\%} = 0.45(HT_{core} + HT_{70\%})$$

HT_{core} = core OD after finish
 $HT_{70\%}$ = wound coil OD

For other winding factors, OD dimension can be approximated by:

$$r_x = \sqrt{\frac{x}{40} (r_{40\%}^2 - r_{core}^2) + r_{core}^2}$$

where:

r_x = radius at unique winding factor
 x = winding factor
 $OD_x = 2r_x$

Temperature Rise Calculation

Heat to be dissipated in a magnetic component arises from energy losses due to DC resistance in the coil (I^2R); AC copper losses, if high frequency AC current is present; and AC core losses, if AC current is present. (DC current does not result in any core losses, regardless of the magnitude.) Heat dissipation and temperature rise (ΔT) depend on many factors, so there is no simple way to predict ΔT precisely. But the following formula is useful for approximating ΔT for a component in still air.

$$\text{Temperature Rise } (^{\circ}\text{C}) = \left(\frac{\text{Total Power Loss (mW)}}{\text{Surface Area (cm}^2\text{)}} \right)^{0.833}$$

Surface Area is that of the wound component. In this catalog, surface area is presented in two ways:

1. Unwound, coated core
2. Wound core, assuming 40% winding factor

Powder Core Loss Calculation

Core loss is generated by changing magnetic flux field within a material, since no magnetic materials exhibit perfectly efficient magnetic response. Core loss density (PL) is a function of half of the AC flux swing ($\frac{1}{2} \Delta B = B_{pk}$) and frequency (f). It can be approximated from core loss charts or the curve fit loss equation:

$$PL = a B_{pk}^b f^c$$

where a, b, c are constants determined from curve fitting, and B_{pk} is defined as half of the AC flux swing:

$$B_{pk} = \frac{\Delta B}{2} = \frac{B_{AC\ max} - B_{AC\ min}}{2}$$

Units typically used are (mW/cm³) for PL; Tesla(T) for B_{pk} ; and (kHz) for f .
The task of core loss calculation is to determine B_{pk} from known design parameters.

Method 1 – Determine B_{pk} from DC Magnetization Curve. $B_{pk} = f(H)$

Flux density (B) is a non-linear function of magnetizing field (H), which in turn is a function of winding number of turns (N), current (I), and magnetic path length (l_e). The value of B_{pk} can typically be determined by first calculating H at each AC extreme:

$$H_{AC\ max} = \left[\frac{N}{l_e} \left(I_{DC} + \frac{\Delta I}{2} \right) \right]$$

$$H_{AC\ min} = \left[\frac{N}{l_e} \left(I_{DC} - \frac{\Delta I}{2} \right) \right]$$

$$B = f(H)$$

Units typically used are (A-T/cm) for H.

From $H_{AC\ max}$, $H_{AC\ min}$, and the BH curve (or BH curve fit equation), $B_{AC\ max}$, $B_{AC\ min}$ and therefore B_{pk} can be determined.

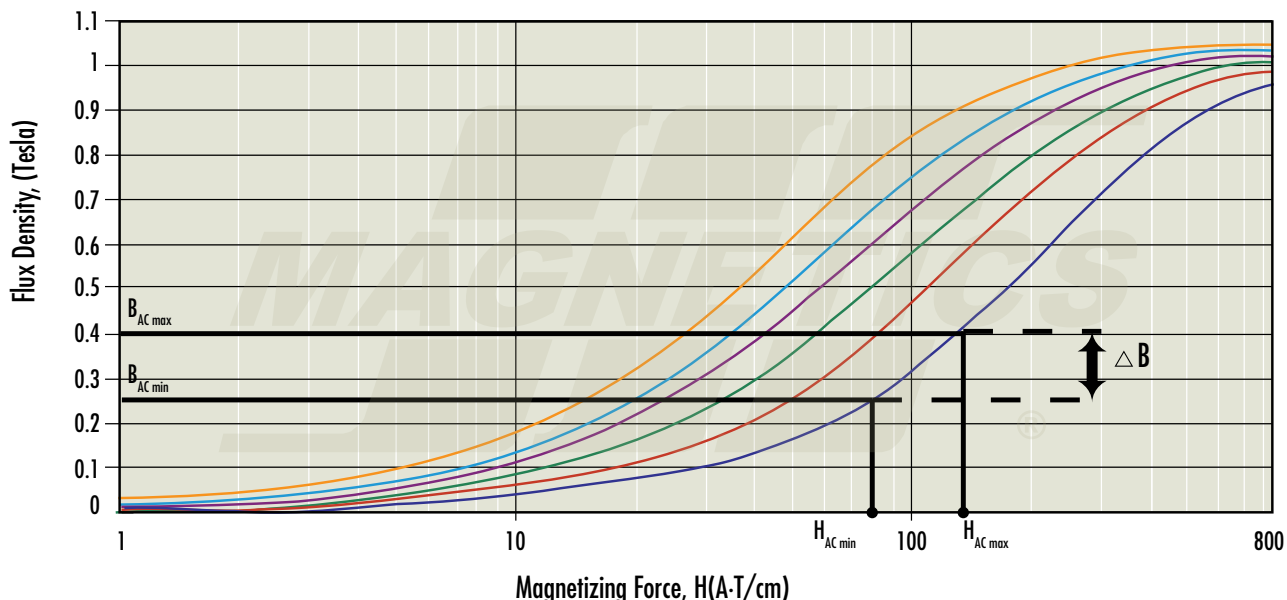

Powder Core Loss Calculation

Example 1 – AC current is 10% of DC current:

Approximate the core loss of an inductor with 20 turns wound on Kool Mμ p/n 77894A7 (60μ , $l_e=6.35\text{cm}$, $A_e=0.654\text{cm}^2$, $A_L=75\text{nH/T}^2$). Inductor current is 20 Amps DC with ripple of 2 Amps peak-peak at 100kHz.

1.) Calculate H and determine B from BH curve or curve fit equation:

$$H_{AC\max} = \frac{20}{6.35} \left(20 + \frac{2}{2}\right) = 66.14 \text{ A}\cdot\text{T}/\text{cm} \rightarrow B_{AC\max} \sim 0.44\text{T}$$

$$H_{AC\min} = \frac{20}{6.35} \left(20 - \frac{2}{2}\right) = 59.84 \text{ A}\cdot\text{T}/\text{cm} \rightarrow B_{AC\min} \sim 0.41\text{T}$$

$$\rightarrow B_{pk} = \frac{\Delta B}{2} = \frac{0.44 - 0.41}{2} = 0.015\text{T}$$

2.) Determine Core Loss density from chart or calculate from loss equation:

$$PL = 193 \times 0.015^{2.01} \times 100^{1.29} \sim 20 \frac{\text{mW}}{\text{cm}^3}$$

3.) Calculate core loss:

$$P_{fe} = PL \times l_e \times A_e \sim 20 \times 6.35 \times 0.654 \sim 80\text{mW}$$

Example 2 – AC current is 40% of DC current:

Approximate the core loss for the same 20-turn inductor, with same inductor current of 20 Amps DC but ripple of 8 Amps peak-peak at 100kHz.

1.) Calculate H and determine B from BH curve:

$$H_{AC\max} = \frac{20}{6.35} \left(20 + \frac{8}{2}\right) = 75.59 \text{ A}\cdot\text{T}/\text{cm} \rightarrow B_{AC\max} \sim 0.48\text{T}$$

$$H_{AC\min} = \frac{20}{6.35} \left(20 - \frac{8}{2}\right) = 50.39 \text{ A}\cdot\text{T}/\text{cm} \rightarrow B_{AC\min} \sim 0.36\text{T}$$

$$\rightarrow B_{pk} = \frac{\Delta B}{2} = \frac{0.48 - 0.36}{2} = 0.06\text{T}$$

2.) Determine Core Loss density from chart or calculate from loss equation:

$$PL = 193 \times 0.06^{2.01} \times 100^{1.29} \sim 300 \frac{\text{mW}}{\text{cm}^3}$$

3.) Calculate core loss:

$$P_{fe} = PL \times l_e \times A_e = 300 \times 6.35 \times 0.654 \sim 1\text{W}$$

Powder Core Loss Calculation

Example 3 – pure AC, no DC:

Approximate the core loss for the same 20-turn inductor, now with 0 Amps DC and 8 Amps peak-peak at 100kHz.

1.) Calculate H and determine B from BH curve:

$$H_{AC\ max} = \left[\frac{20}{6.35} \left(\frac{8}{2} \right) \right] = 12.60\ \text{A}\cdot\text{T}/\text{cm} \rightarrow B_{AC\ max} \sim 0.11\ \text{T}$$

$$H_{AC\ min} = \left[\frac{20}{6.35} \left(-\frac{8}{2} \right) \right] = -12.60\ \text{A}\cdot\text{T}/\text{cm} \rightarrow B_{AC\ min} \sim -0.11\ \text{T}$$

$$\rightarrow B_{pk} = \frac{\Delta B}{2} \sim 0.11\ \text{T}$$

2.) Determine Core Loss density from chart or calculate from loss equation:

$$PL = 193 \times 0.11^{2.01} \times 100^{1.29} \sim 900\ \frac{\text{mW}}{\text{cm}^3}$$

3.) Calculate core loss:

$$P_{fe} = PL \times l_e \times A_e = 900 \times 6.35 \times 0.654 \sim 4\ \text{W}$$

60 μ Kool M μ DC Magnetization Curve

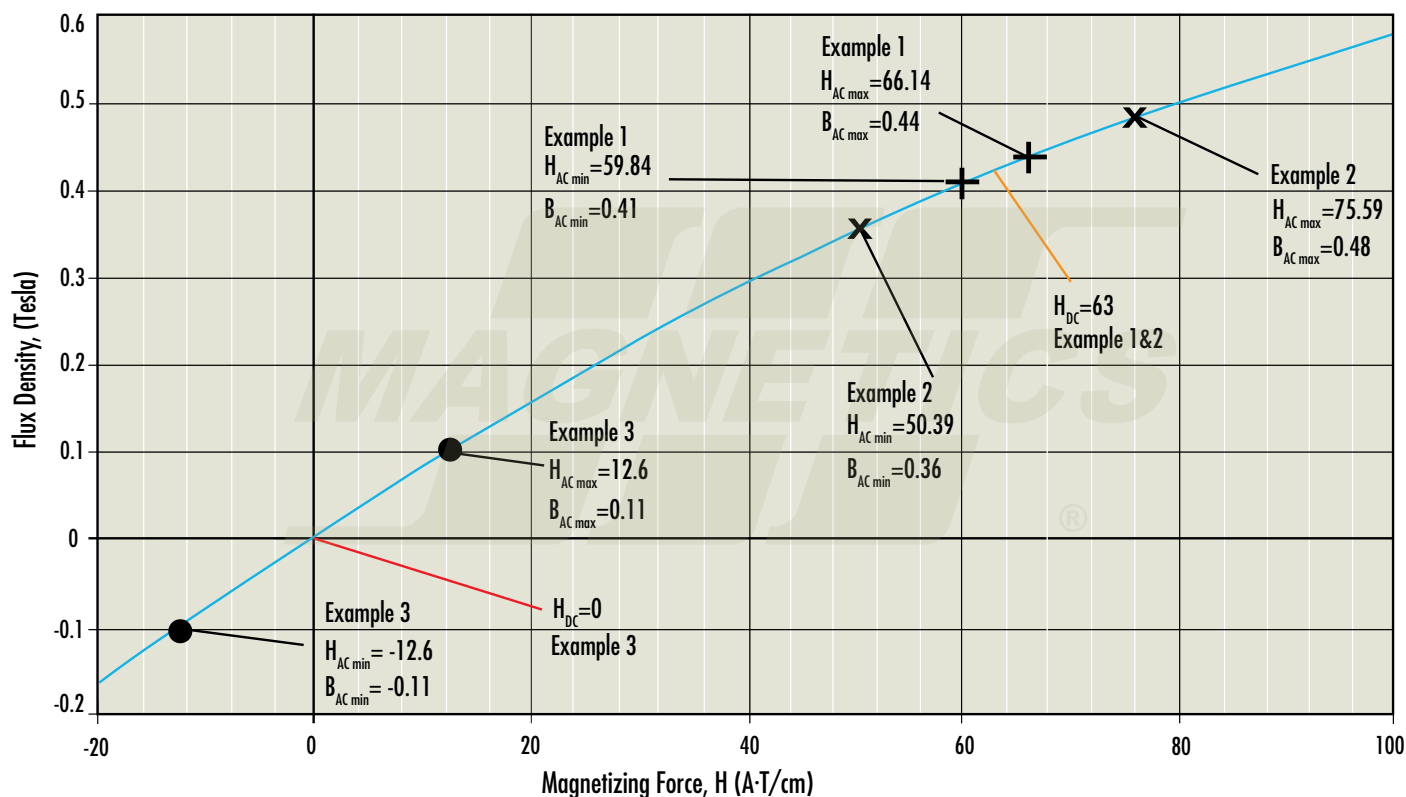

Note the significant influence of DC bias on core loss, comparing Example 3 with Example 2. Lower permeability results in less B_{pk} , even if the current ripple is the same. This effect can be achieved with DC bias, or by selecting a lower permeability material.

Where AC is small, the following methods (2 and 3) can be used to approximate B_{pk} .

Powder Core Loss Calculation

Method 2, Determine B_{pk} from effective perm at DC bias. $B_{pk} = f(\mu_e, \Delta H)$

The instantaneous slope of the BH curve is defined as the absolute permeability, which is the product of permeability of free space ($\mu_0=4\pi \times 10^{-7}$) and the material permeability (μ), which varies along the BH curve. For small AC, this slope can be modeled as a constant throughout AC excitation, with μ approximating the effective perm at DC bias (μ_e):

$$\frac{dB}{dH} = \mu_0 \mu_e \quad \rightarrow \quad \Delta B = \mu_0 \mu_e \Delta H$$

$$\rightarrow \frac{\Delta B}{\Delta H} = \mu_0 \mu_e \quad B_{pk} = \frac{\Delta B}{2} = 0.5 \times \mu_0 \mu_e \Delta H$$

The effective perm with DC bias is more commonly written in terms of % of initial perm and can be obtained from the DC bias curve or curve fit equation:

$$B_{pk} = 0.5 \times \mu_0 \times (\% \mu_i)(\mu_i) \times \Delta H \quad \text{where} \quad \Delta H = \frac{N \Delta I}{l_e}$$

Reworking Example 1 (20 Amps DC, 2 Amps p-p)

$$H_{DC} = \left[\frac{20}{6.35} (20) \right] = 63 \text{ A-T/cm} \rightarrow \text{From chart of curve fit equation, } \% \mu_i = 0.57$$

$$\mu_i = 60$$

$$\Delta H = \frac{N \Delta I}{l_e} = \frac{20(2)}{6.35} = 6.3 \text{ A-T/cm}$$

$$B_{pk} = 0.5(4\pi \times 10^{-7})(0.57)(60)(630) = 0.014\text{T (compare to 0.015T using Method 1)}$$

Reworking Example 2 (20 Amps DC, 8 Amps p-p)

From example 1, $H_{DC} = 63 \text{ A-T/cm}, \% \mu_i = 0.57; \mu_i = 60$

$$\Delta H = \frac{N \Delta I}{l_e} = \frac{20(8)}{6.35} = 25.2 \text{ A-T/cm}$$

$$B_{pk} = 0.5(4\pi \times 10^{-7})(0.57)(60)(2520) = 0.054\text{T (compare to 0.06T using Method 1)}$$

Reworking Example 3 (0 Amps DC, 8 Amps p-p)

From example 2,

$$\Delta H = 2520 \text{ A-T/m}$$

$$H_{DC} = 0 \text{ A-T/cm} \quad \% \mu_i = 1$$

$$B_{pk} = 0.5(4\pi \times 10^{-7})(1)(60)(2520) = 0.095\text{T (compare to 0.11T using Method 1)}$$

Powder Core Loss Calculation

Method 3, Determine B_{pk} from biased inductance. $B_{pk} = f(L, I)$

B can be rewritten in terms of inductance by considering Faraday's equation and its effect on inductor current:

$$\rightarrow V_L = NA \frac{dB}{dt} = L \frac{dI}{dt}$$

$$\rightarrow dB = \frac{L}{NA} dI$$

Where L varies non-linearly with I. For small AC, L is assumed constant throughout AC excitation and approximates biased inductance (L_{DC}).

$$\rightarrow \Delta B = \frac{L_{DC} \Delta I}{NA}$$

$$\rightarrow B_{pk} = \frac{L_{DC} \Delta I}{2NA_e}$$

Another way of looking at this is by rewriting the relationship between B and L as:

$$\rightarrow \frac{dB}{dH} = \frac{L}{NA} \frac{dI}{dH}$$

Substituting (dH/dI) with (N/I_e) and A with A_e :

$$\rightarrow \frac{dB}{dH} = \frac{L I_e}{N^2 A_e}$$

Where L varies non-linearly with H. For small AC, the slope of the BH curve is assumed constant throughout AC excitation, and L approximates the biased inductance (L_{DC}).

$$\rightarrow \frac{\Delta B}{\Delta H} = \frac{L_{DC} I_e}{N^2 A_e}$$

$$\rightarrow B_{pk} = \frac{L_{DC} \Delta I}{2NA_e}$$

$$\rightarrow \Delta B = \frac{L_{DC} I_e}{N^2 A_e} \Delta H = \frac{L_{DC} \Delta I}{NA_e}$$

Powder Core Loss Calculation

Reworking Example 1:

$$L_{nl} \text{ (no load)} = A_L \times N^2 = 75 \text{ nH/T}^2 \times 20^2 = 30 \mu\text{H}$$

$$L_{DC} \text{ (20A)} = (\% \mu_r)(L_{nl}) = (0.57)(30) = 17.1 \mu\text{H}$$

$$\rightarrow B_{pk} = \frac{(17.1 \times 10^{-6})(2)}{2(20)(0.654 \times 10^{-4})} = 0.013\text{T (compare to 0.015T per Method 1, 0.014T per Method 2).}$$

Reworking Example 2:

From example 1, $L_{AC} = 17.1 \mu\text{H}$

$$\rightarrow B_{pk} = \frac{(17.1 \times 10^{-6})(8)}{2(20)(0.654 \times 10^{-4})} = 0.052\text{T (compare to 0.06T per Method 1, 0.054 per Method 2).}$$

Reworking Example 3:

$$L_{DC} = L_{nl} = 30 \mu\text{H}$$

$$\rightarrow B_{pk} = \frac{(30 \times 10^{-6})(8)}{2(20)(0.654 \times 10^{-4})} = 0.092\text{T (compare to 0.11T per Method 1, 0.095T per Method 2).}$$

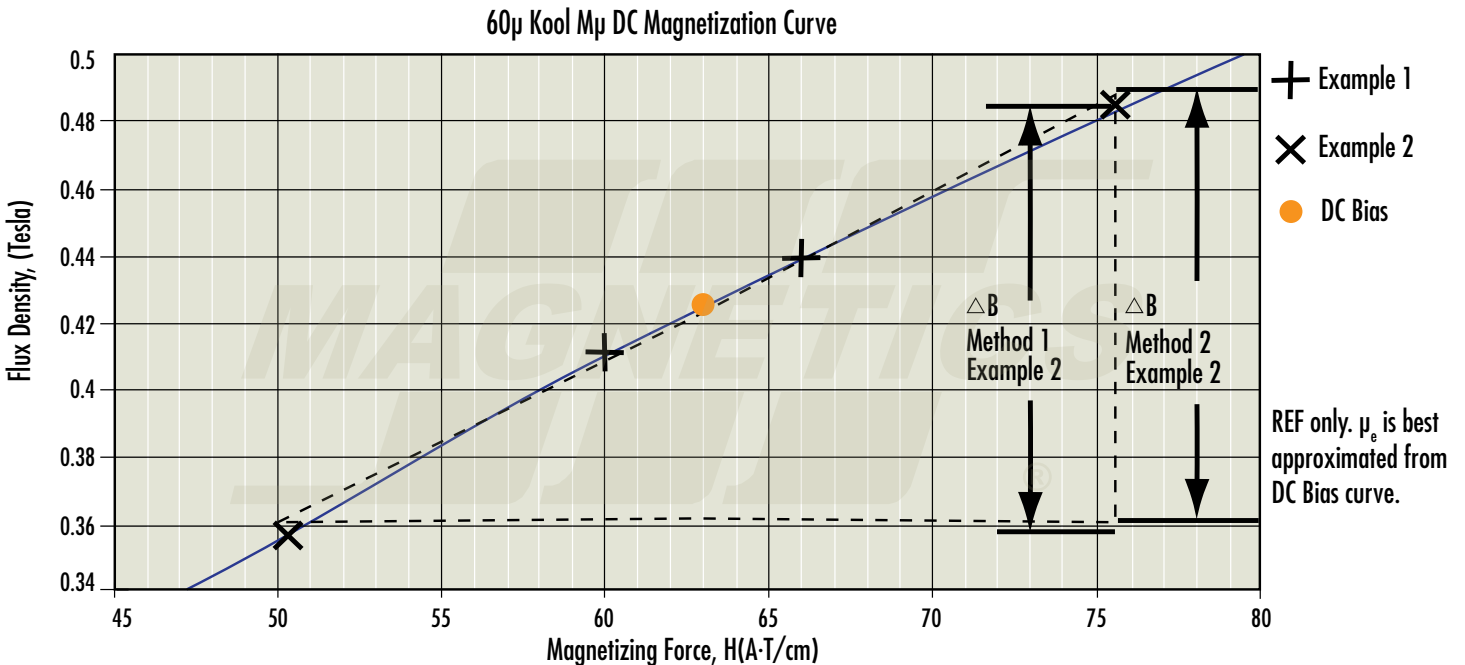

Material Properties

	PERMEABILITY VS. T, B, & f - TYPICAL			
	Permeability (μ)	μ vs. T dynamic range (-50° C TO +100° C) MATERIALS RATED TO 200° C	μ vs. B dynamic range 0 to 400 mT	μ vs. f. flat to...
MPP	14 μ	0.7%	+0.4%	4 MHz
	26 μ	0.9%	+0.4%	3 MHz
	60 μ	1.0%	+0.8%	2 MHz
	125 μ	1.3%	+1.4%	300 kHz
	147 μ , 160 μ , 173 μ	1.5%	+1.9%	200 kHz
	200 μ	1.6%	+2.8%	100 kHz
	300 μ	1.6%	+4.5%	90 kHz
High Flux	550 μ	8.7%	+21.0%	20 kHz
	14 μ	1.5%	+5.0%	3 MHz
	26 μ	2.0%	+9.0%	1.5 MHz
	60 μ	2.6%	+13.5%	1 MHz
	125 μ	3.6%	+19.0%	700 kHz
	147 μ	4.8%	+22.0%	500 kHz
Kool Mμ[®]	160 μ	5.5%	+25.0%	400 kHz
	26 μ	1.7%	+1.0%	2 MHz
	40 μ	2.2%	+1.1%	1 MHz
	60 μ	3.4%	+1.4%	900 kHz
	75 μ	4.5%	+2.0%	500 kHz
	90 μ	5.2%	+2.8%	500 kHz
XFLux[®]	125 μ	8.3%	+3.4%	300 kHz
	60 μ	3.0%	+14.5%	500 kHz

	Curie Temperature	Density	Coefficient of Thermal Expansion
MPP	460°C	8.0 grams/cm ³	12.9 x 10 ⁻⁶ /°C
High Flux	500°C	7.6 grams/cm ³	5.8 x 10 ⁻⁶ /°C
Kool M μ	500°C	5.5 grams/cm ³	10.8 x 10 ⁻⁶ /°C
XFLux	700°C	7.5 grams/cm ³	11.6 x 10 ⁻⁶ /°C

Conversion Tables

To obtain number of	Multiply number of	By
A-T/cm	oersteds	0.795
oersteds	A-T/cm	1.26
tesla	gauss	0.0001
cm ²	in ²	6.452
cm ²	circular mils	5.07 x 10 ⁻⁶
Gauss	mT (milli Tesla)	10
Gauss	Tesla	10,000

Core weights listed in this catalog are for 125μ cores.*

To determine weights for other permeabilities, multiply the 125μ weight by the following factors:

Permeability	14μ	26μ	40μ	60μ	75μ	90μ	125μ	147μ 160μ 173μ	200μ 300μ	550μ
x Factor	0.80	0.86	0.90	0.94	0.96	0.97	1.00	1.02	1.03	1.04

*XF_{LUX}® is based on 60 perm weight.

*MPP, High Flux, and Kool Mμ® in sizes 102, 337, and 165 weight based on 26μ.

Normal Magnetization Curves

MPP

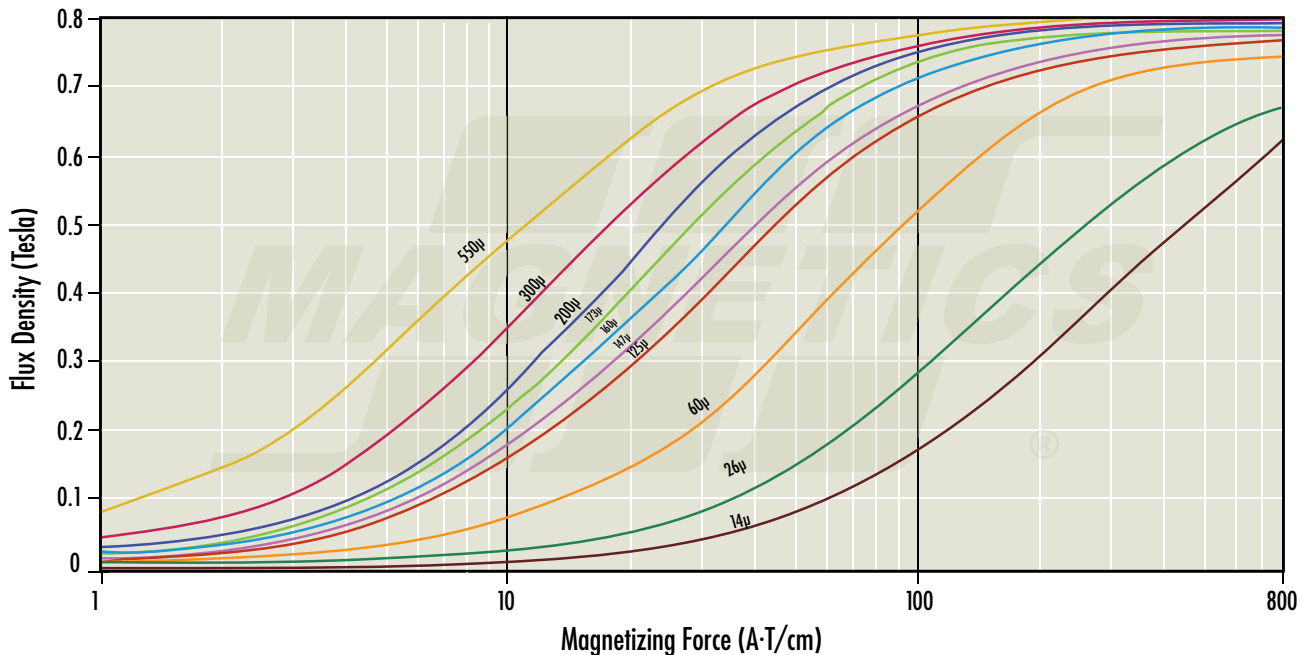

High Flux

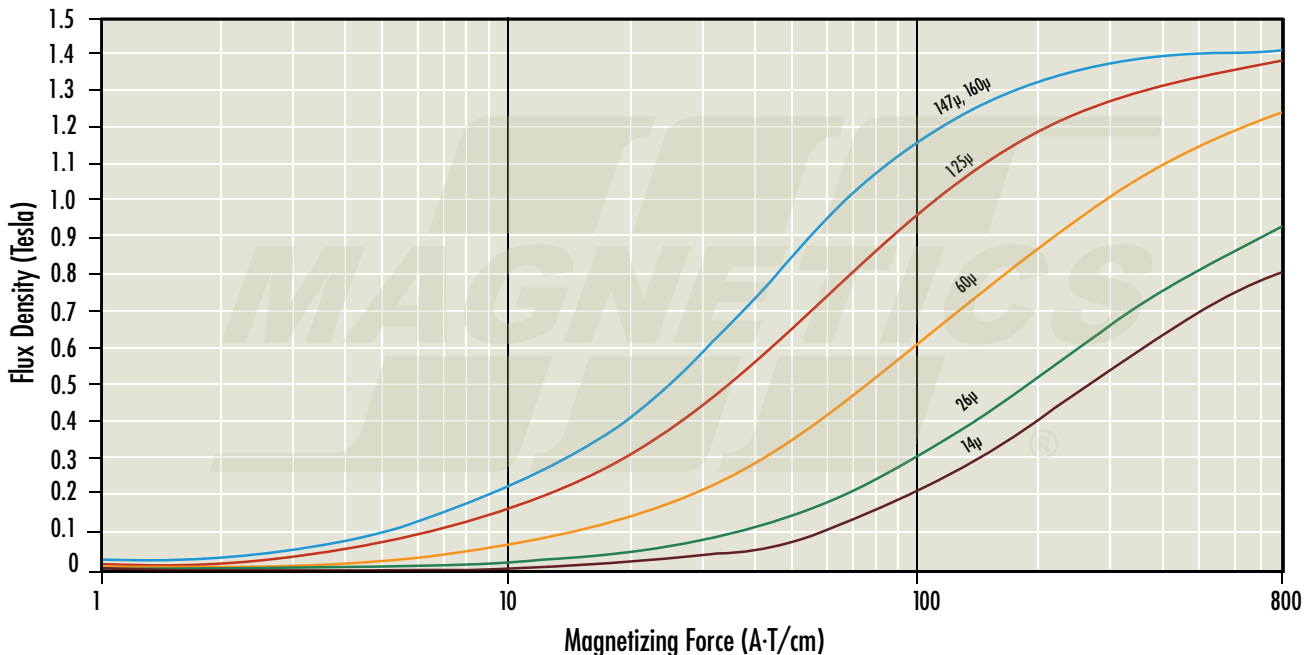

Normal Magnetization Curves

Kool M μ [®]

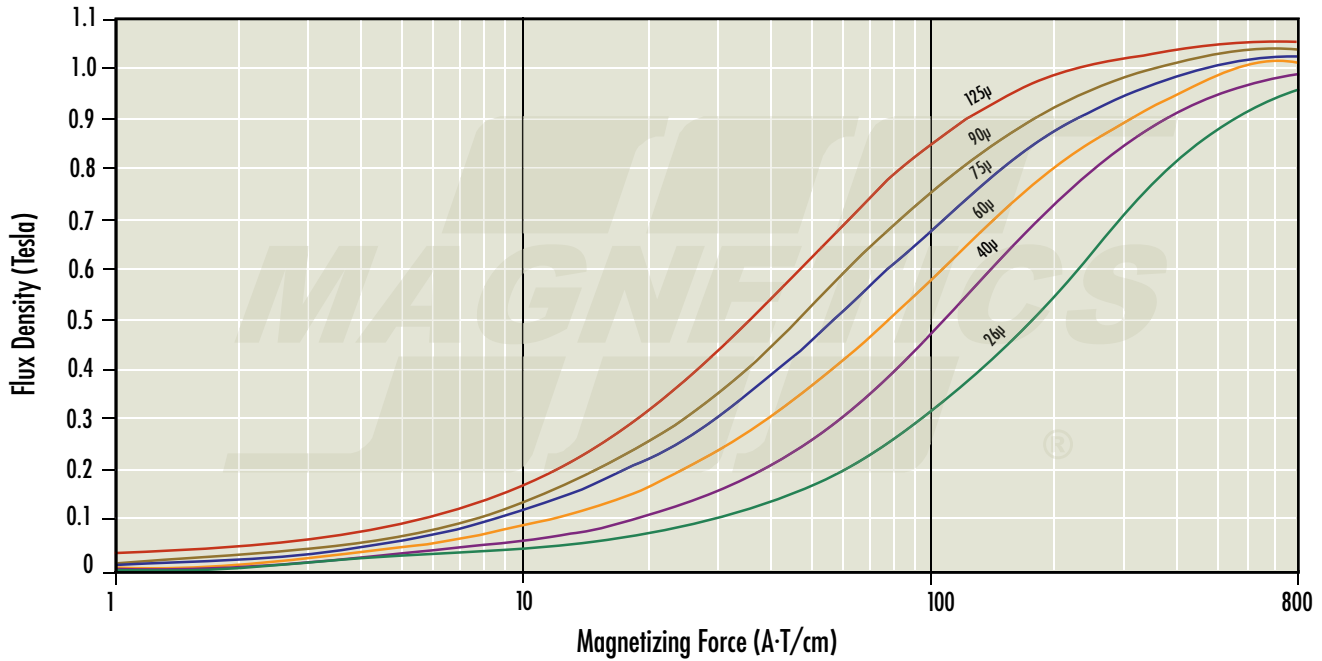

XFLUX[®]

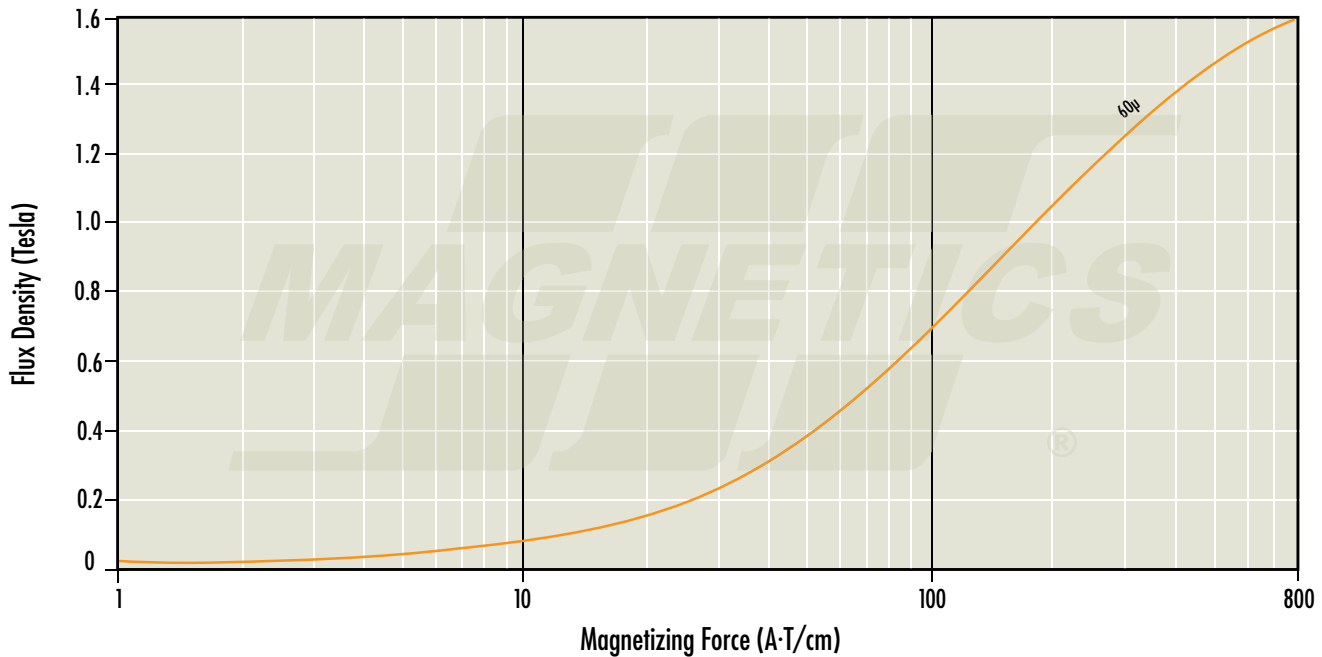

Normal Magnetization Curve

Fit Formula (refer to curves for units)

$$B = \left[\frac{a + bH + cH^2}{1 + dH + eH^2} \right]^x$$

where:

		a	b	c	d	e	x
MPP	14μ	-7.507E+00	6.573E+00	4.619E-01	7.777E+01	4.987E-01	2
	26μ	6.679E-02	1.105E-02	-1.136E-05	1.112E-02	-1.233E-05	2
	60μ	8.146E-02	2.345E-02	6.032E-05	2.476E-02	7.185E-05	2
	125μ	6.420E-04	-6.271E-04	3.253E-04	9.901E-03	5.366E-04	0.5
	147μ	6.530E-04	-7.301E-04	4.516E-04	1.583E-02	7.185E-04	0.5
	160μ	4.470E-04	-5.579E-04	5.211E-04	1.002E-02	8.164E-04	0.5
	173μ	5.450E-04	-7.716E-04	6.506E-04	6.875E-03	1.019E-03	0.5
	200μ	1.001E-03	-1.450E-03	9.127E-04	6.057E-03	1.428E-03	0.5
	300μ	9.400E-04	-1.543E-03	1.990E-03	2.400E-02	3.073E-03	0.5
550μ	7.300E-04	-1.509E-03	6.482E-03	6.371E-02	9.933E-03	0.5	
High Flux	14μ	-5.945E-02	8.703E-03	3.623E-04	5.290E-02	3.474E-04	2
	26μ	-4.067E-02	1.637E-02	3.742E-04	5.316E-02	3.413E-04	2
	60μ	-1.695E-01	1.215E-01	1.213E-02	6.938E-01	1.016E-02	2
	125μ	5.320E-04	-6.811E-04	3.506E-04	1.052E-02	1.694E-04	0.5
	147μ	2.670E-04	-7.829E-04	5.290E-04	2.215E-03	2.606E-04	0.5
	160μ	2.670E-04	-7.829E-04	5.290E-04	2.215E-03	2.606E-04	0.5
Kool Mμ[®]	26μ	5.868E-05	9.362E-05	9.011E-06	-3.682E-04	8.747E-06	0.5
	40μ	8.870E-05	5.592E-05	2.700E-05	2.928E-04	2.574E-05	0.5
	60μ	1.658E-04	2.301E-05	7.297E-05	5.906E-03	6.053E-05	0.5
	75μ	1.433E-05	9.724E-05	1.323E-04	7.255E-03	1.131E-04	0.5
	90μ	5.660E-04	-1.216E-04	1.974E-04	7.278E-03	1.698E-04	0.5
125μ	7.808E-05	5.088E-04	2.595E-04	3.922E-03	2.285E-04	0.5	
XFlux[®]	60μ	-1.695E-01	1.315E-01	1.220E-02	7.434E-01	8.891E-03	2

Core Loss Density Curves

MPP 14 μ

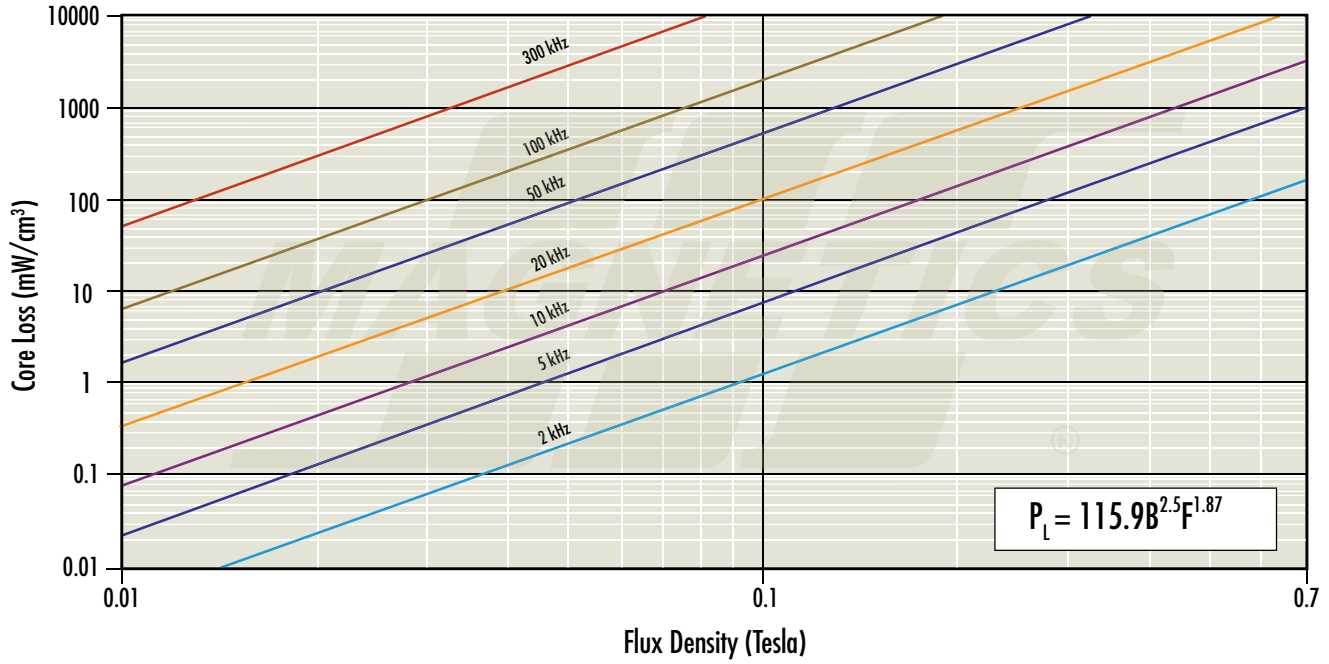

High Flux 14 μ

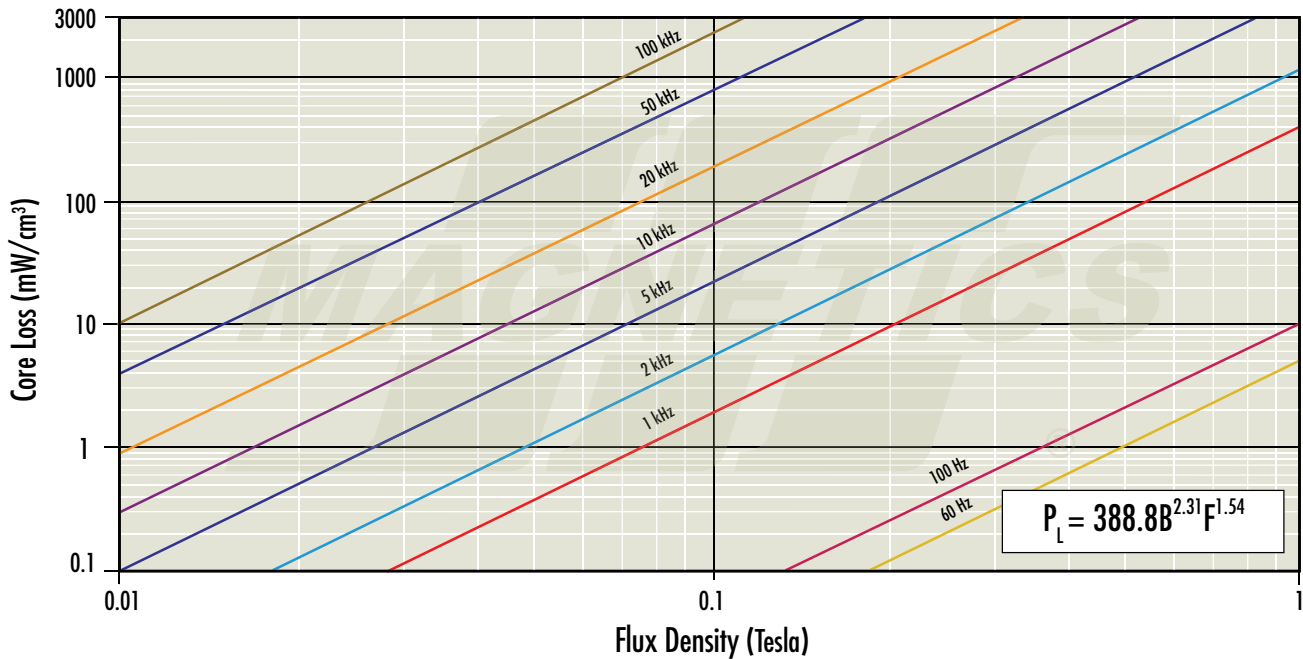

Core Loss Density Curves

MPP 26μ

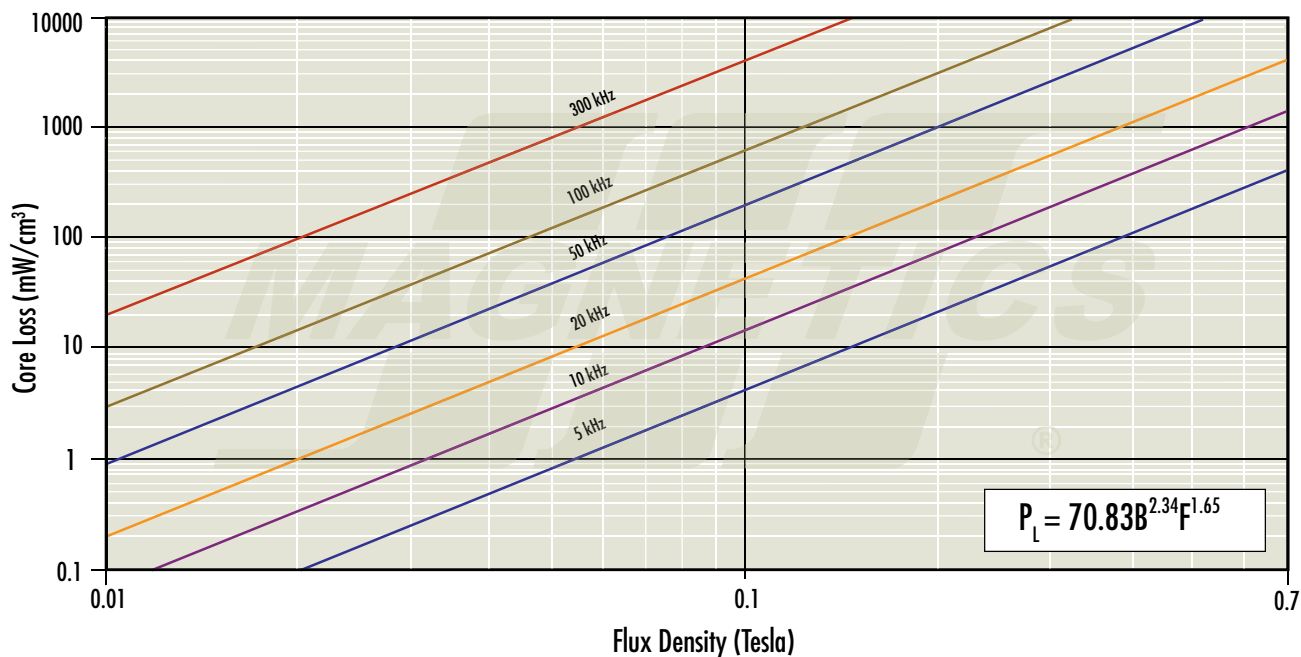

High Flux 26μ

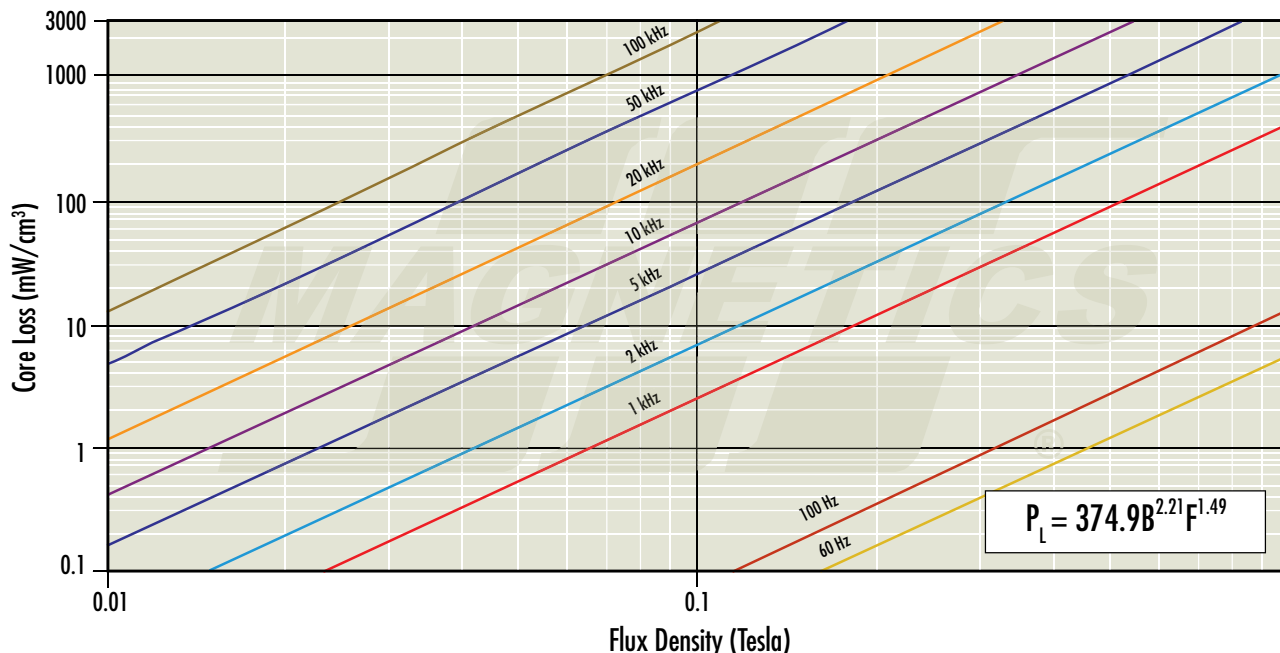

Core Loss Density Curves

MPP 60 μ

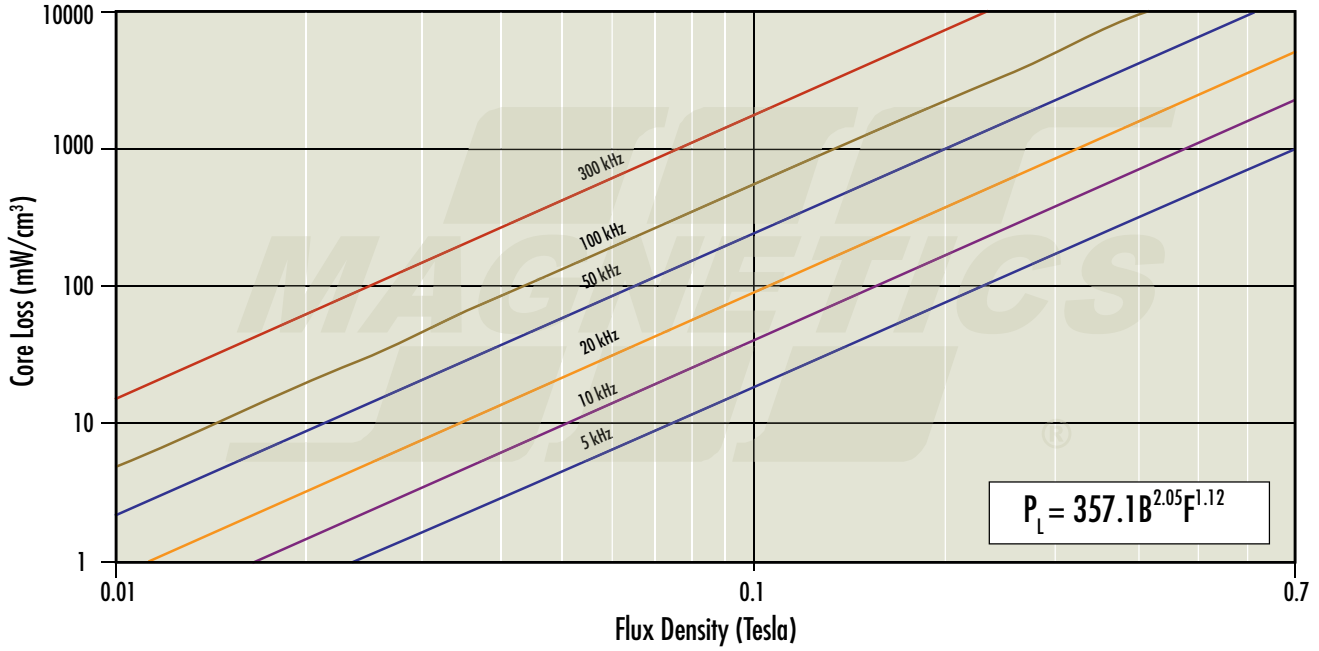

High Flux 60 μ

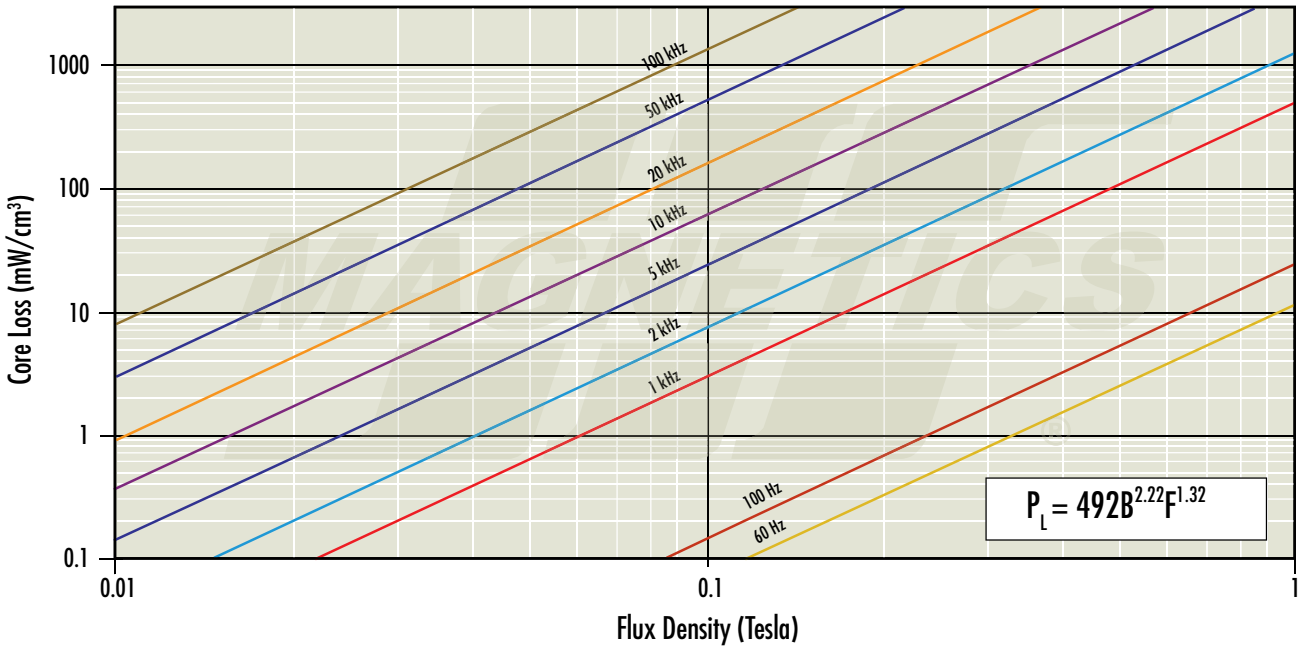

Core Loss Density Curves

MPP 125μ

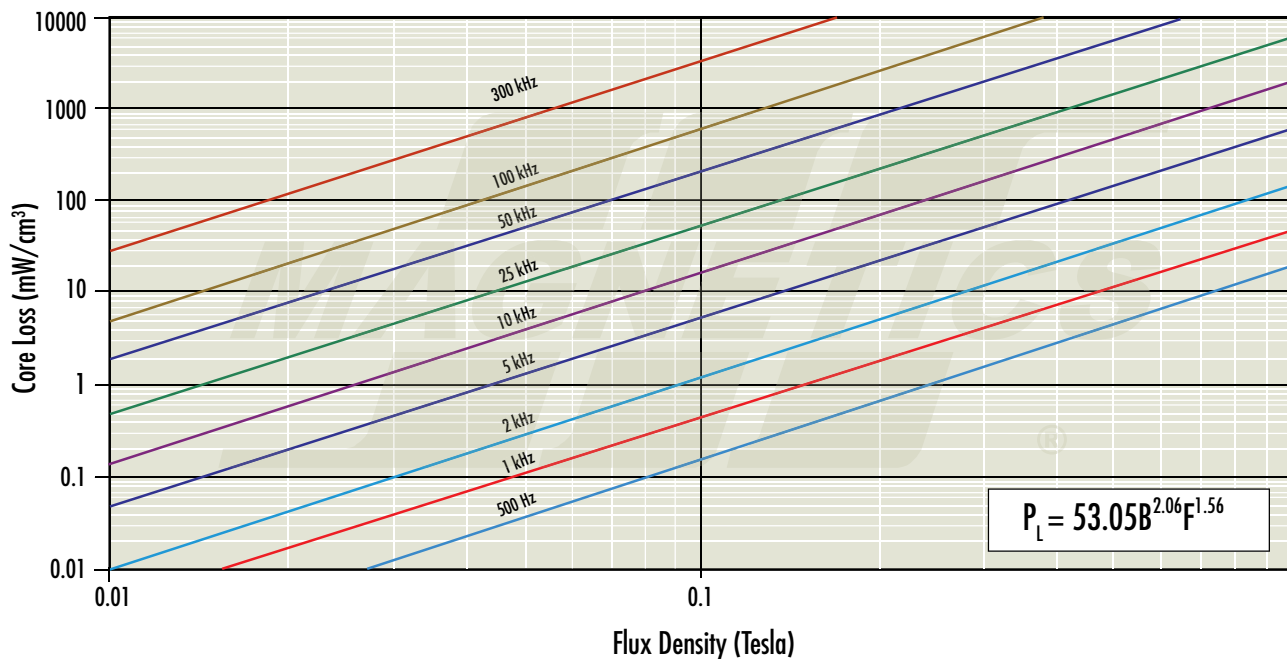

High Flux 125μ

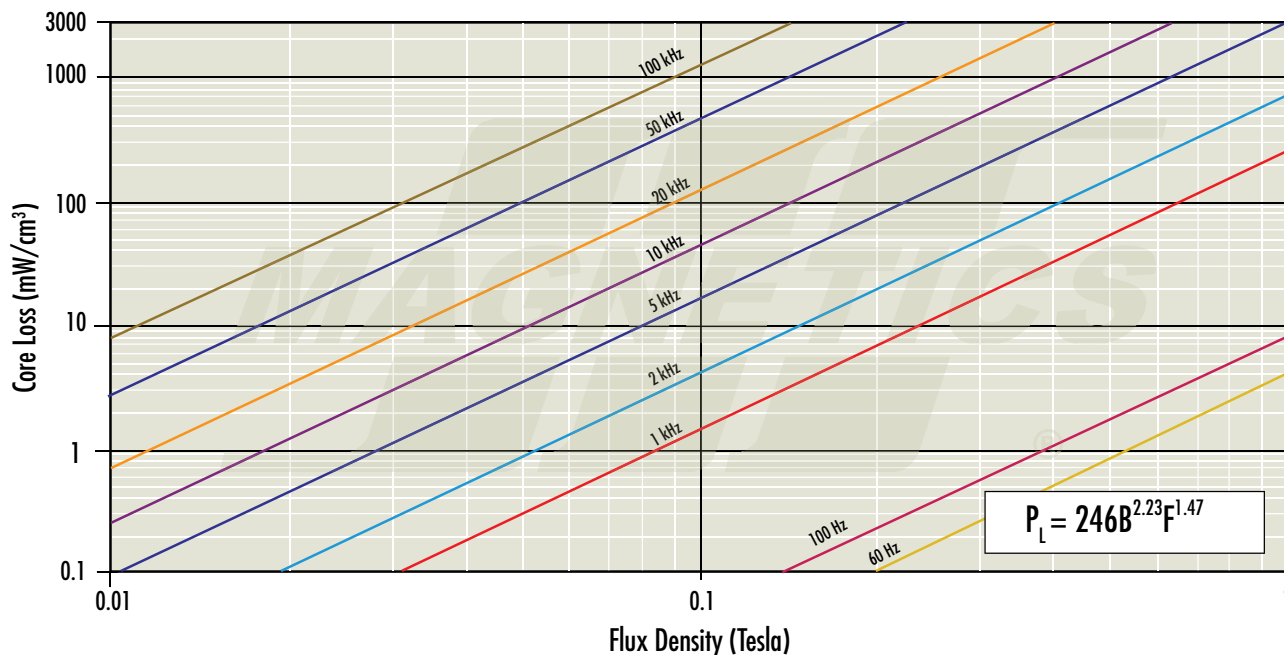

Core Loss Density Curves

MPP 147μ, 160μ, 173μ

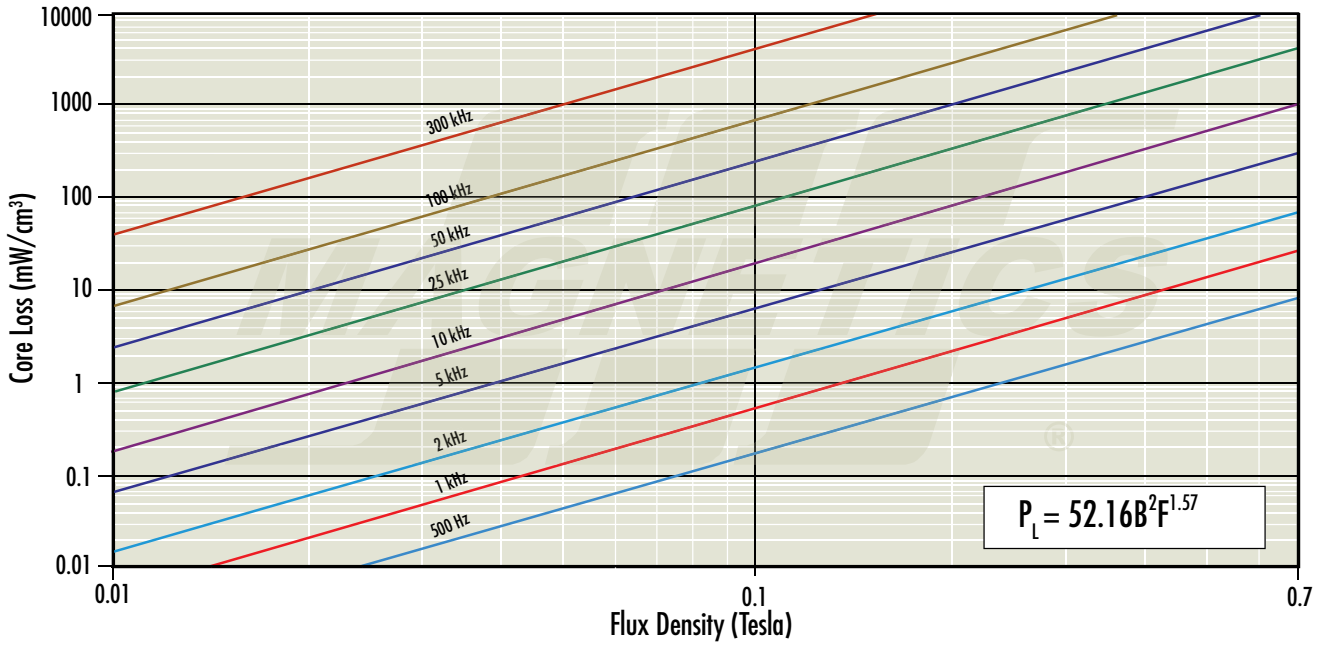

High Flux 147μ, 160μ

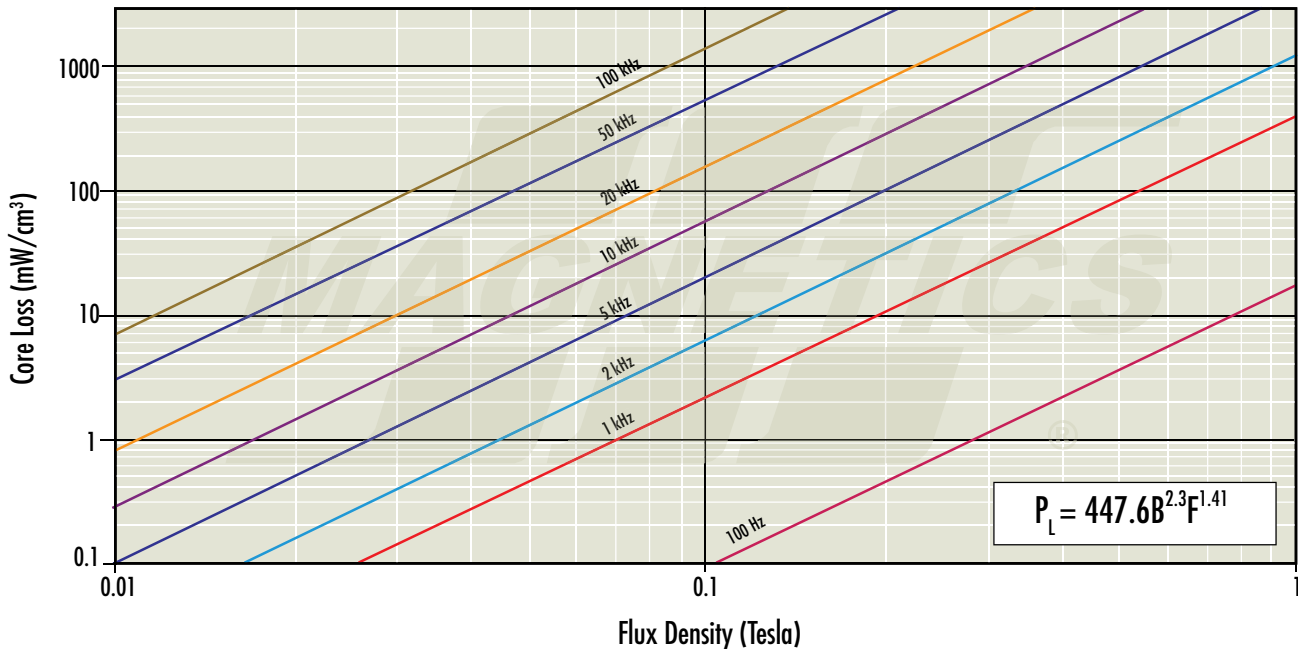

Core Loss Density Curves

MPP 200 μ , 300 μ

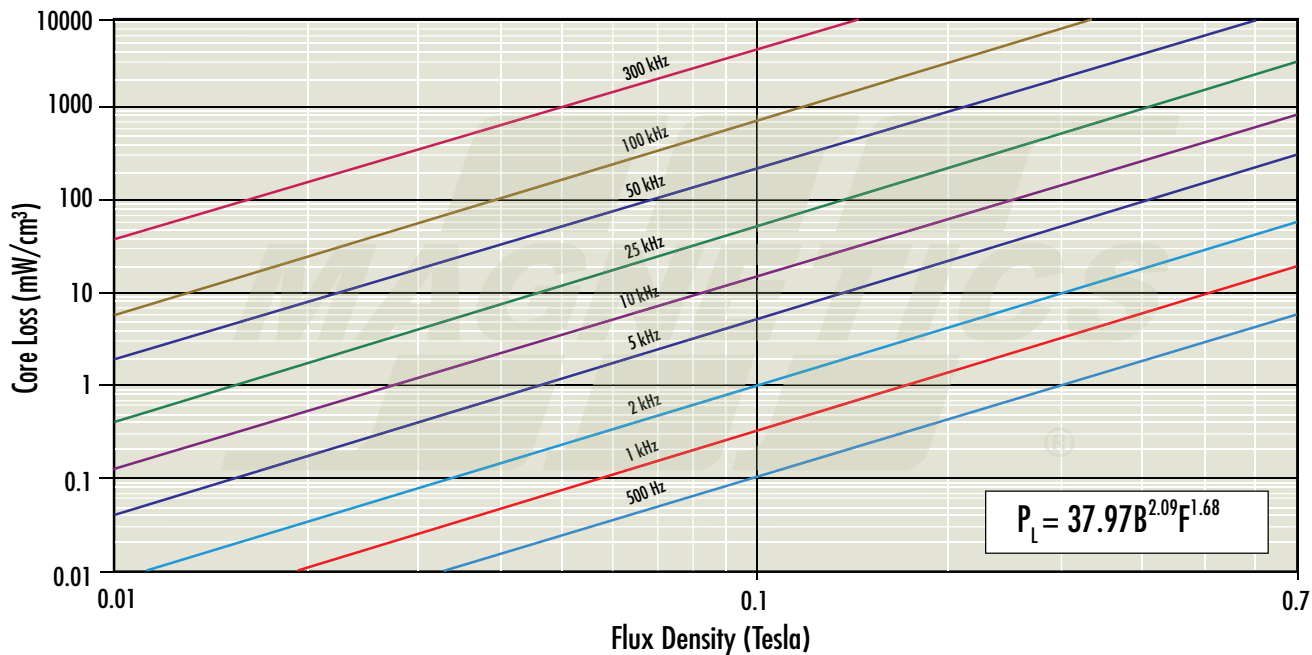

MPP 550 μ

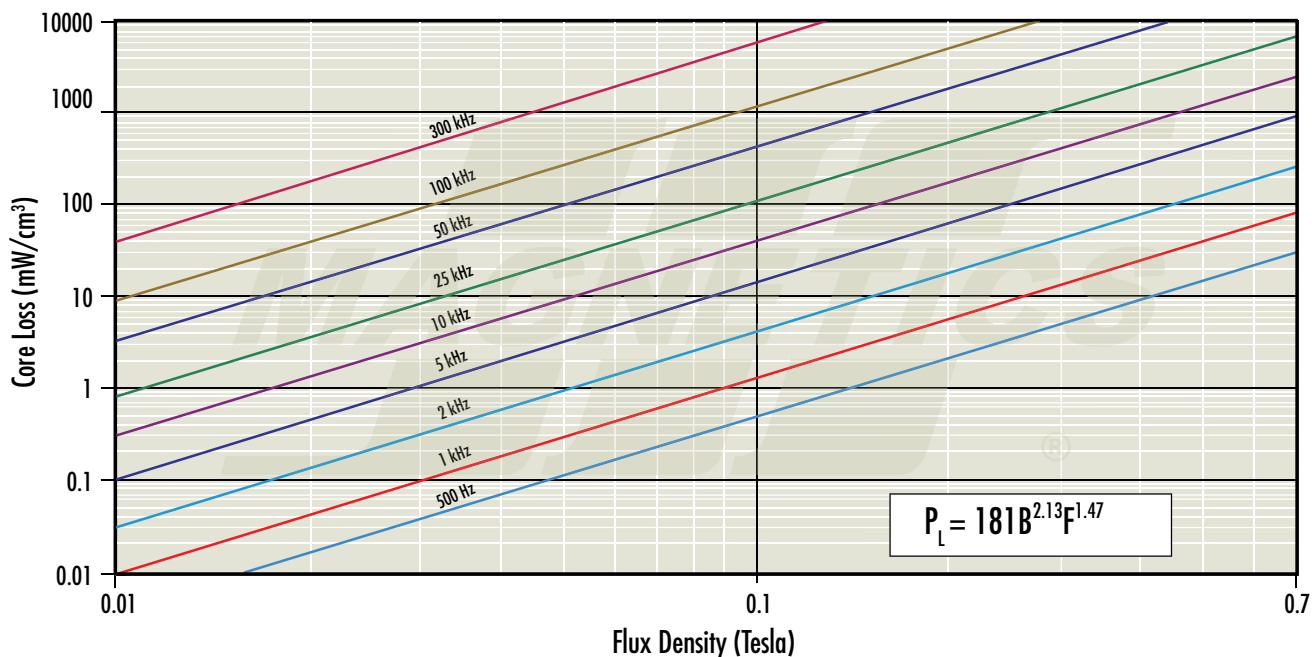

Core Loss Density Curves

Kool M μ [®] 26 μ , 40 μ

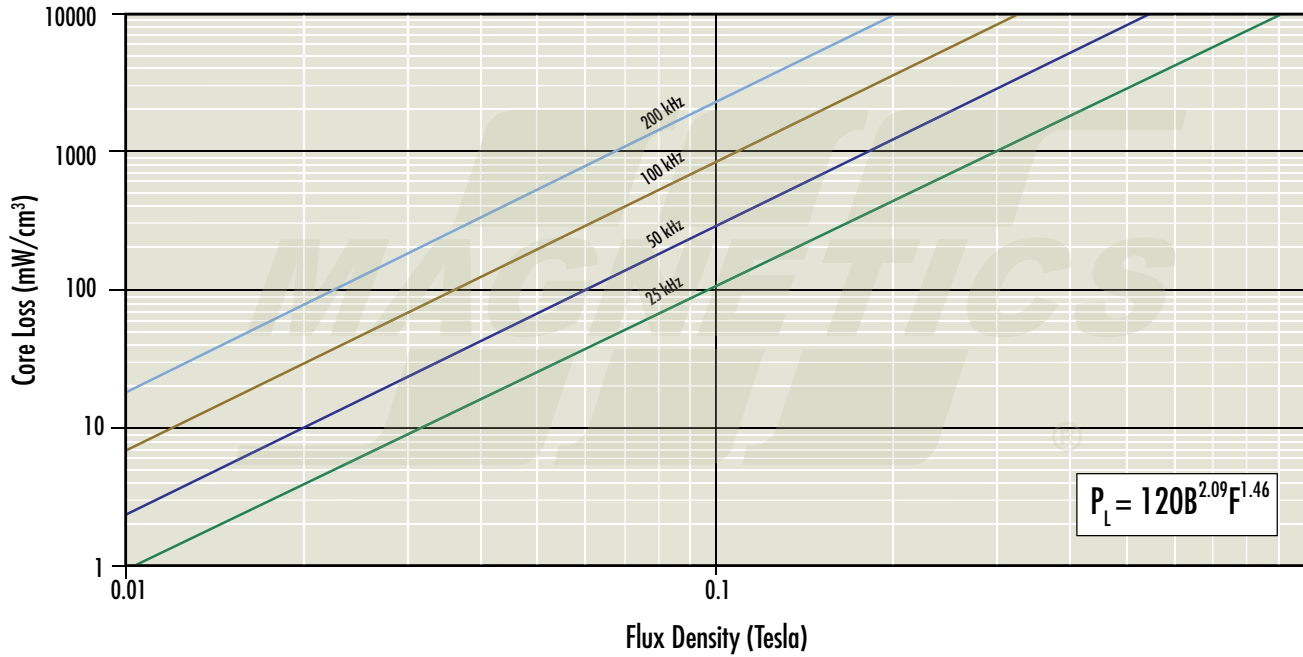

Kool M μ [®] 60 μ , 75 μ , 90 μ

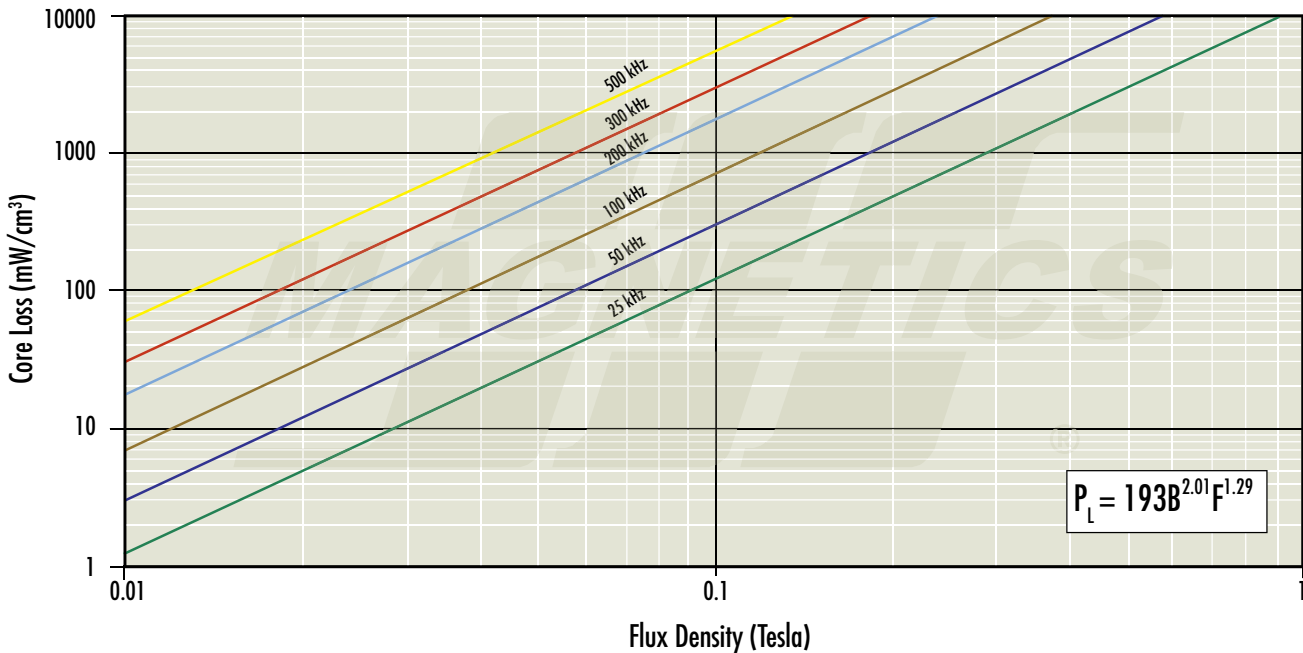

Core Loss Density Curves

Kool M μ [®] 125 μ

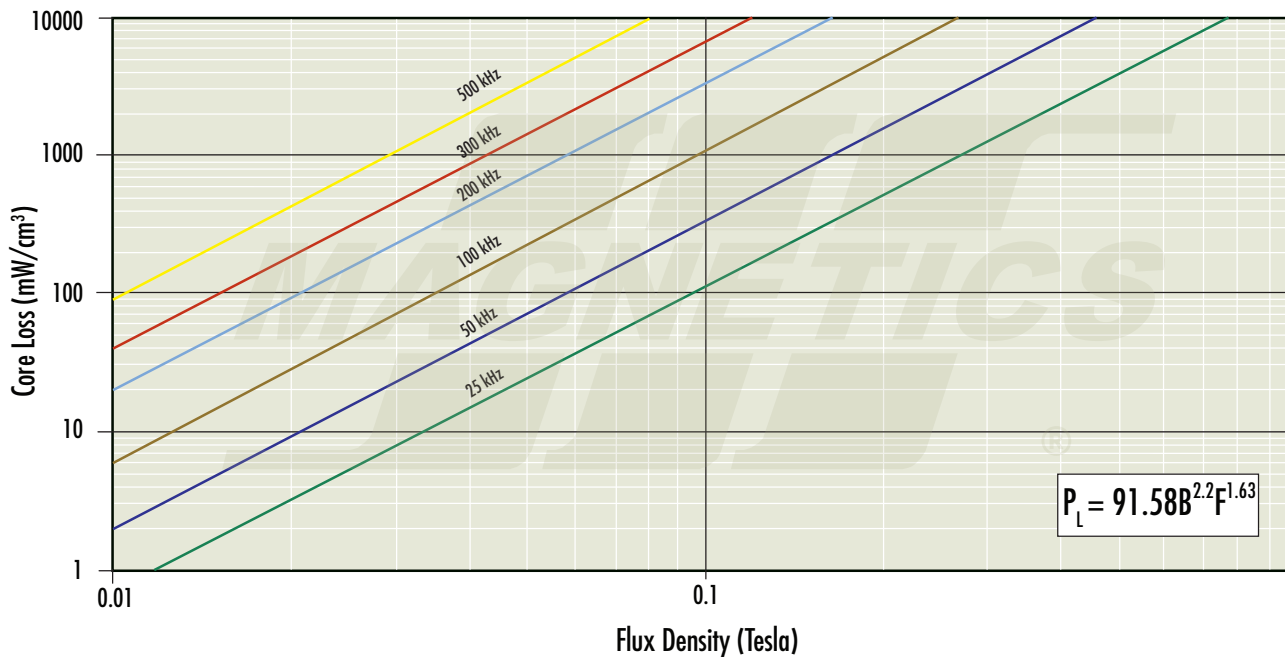

XFLUX[®] 60 μ

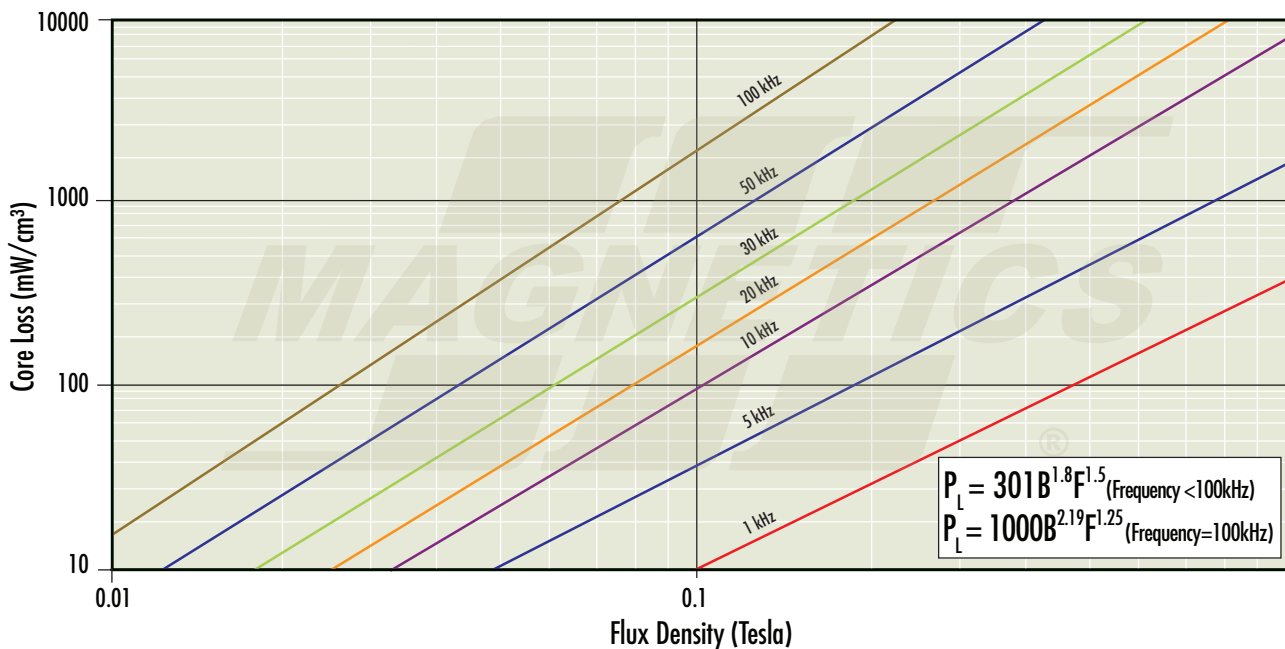

Permeability versus Temperature Curves

MPP (14 μ -300 μ)

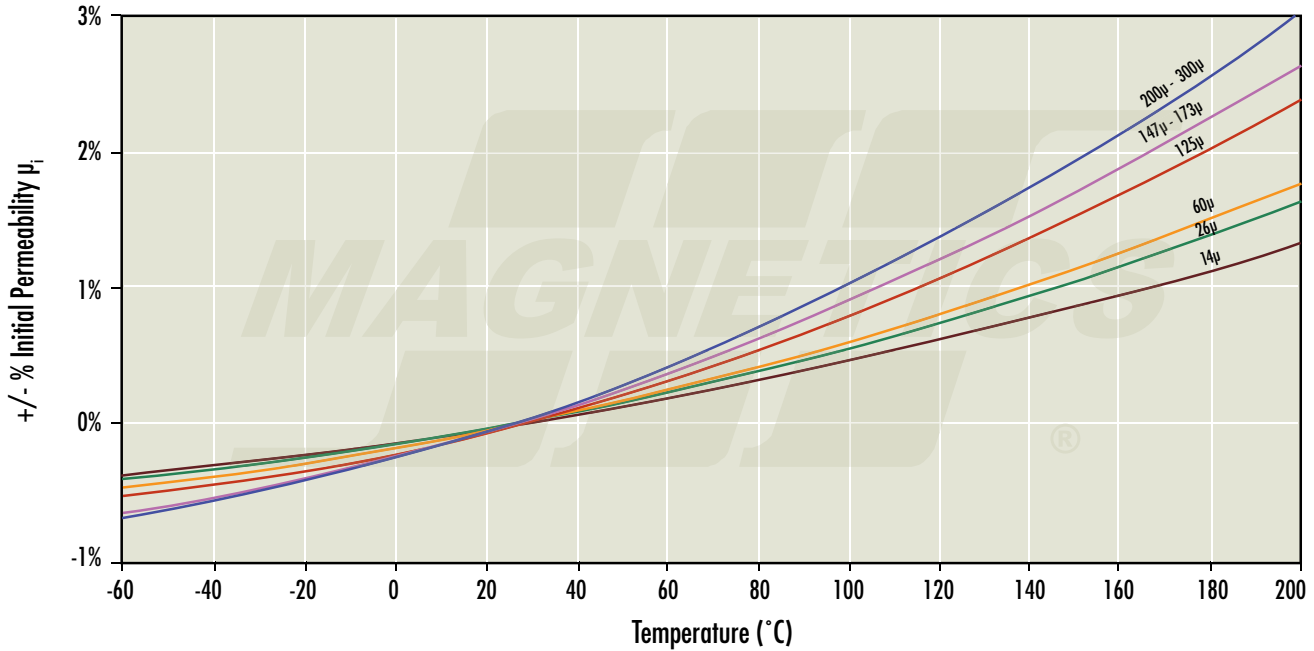

MPP (550 μ)

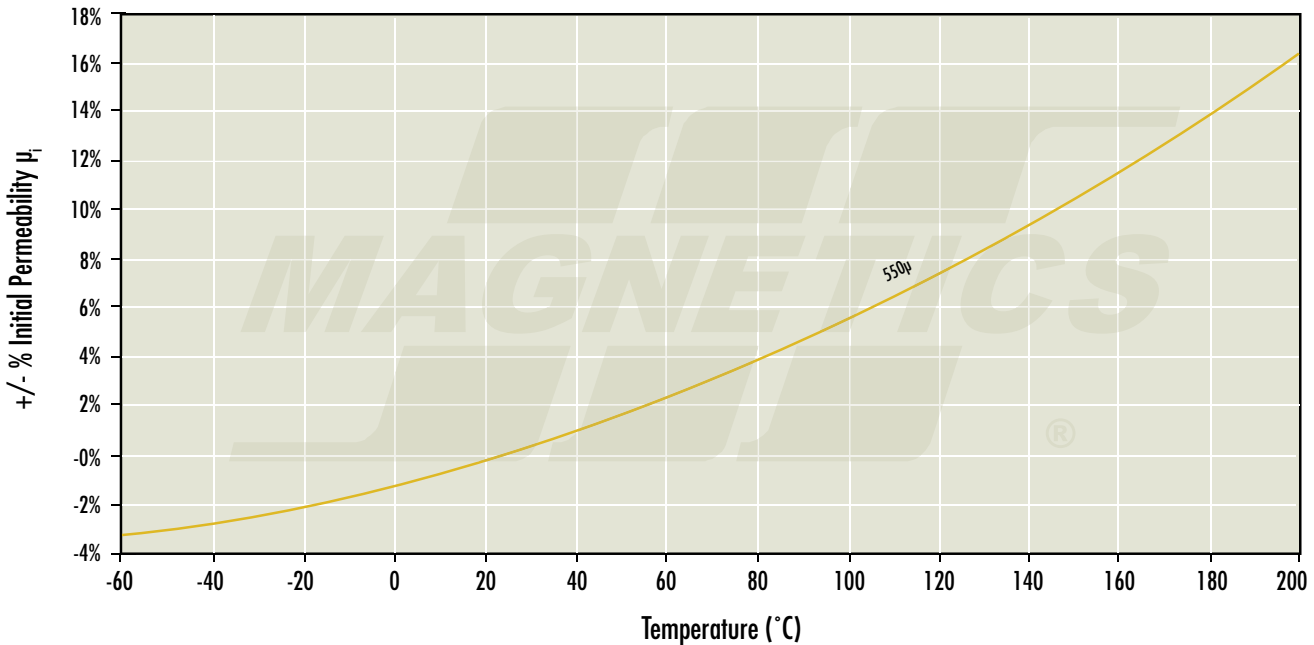

Permeability versus Temperature Curves

High Flux

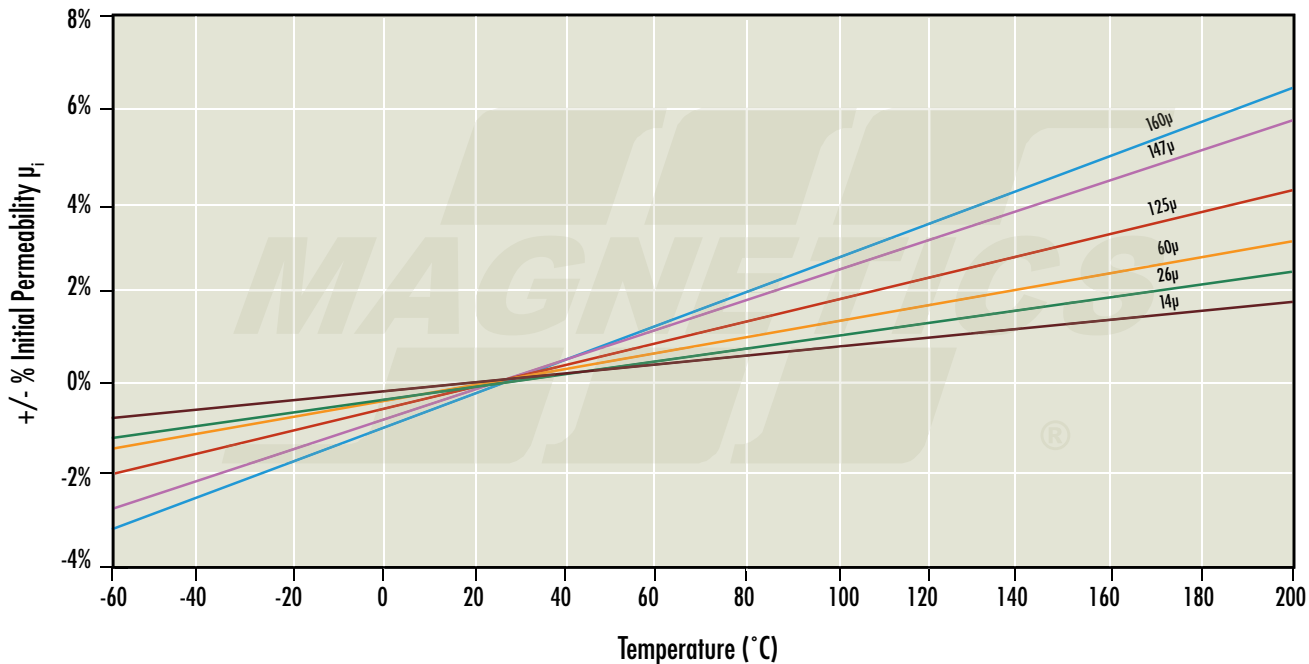

Kool Mµ[®]

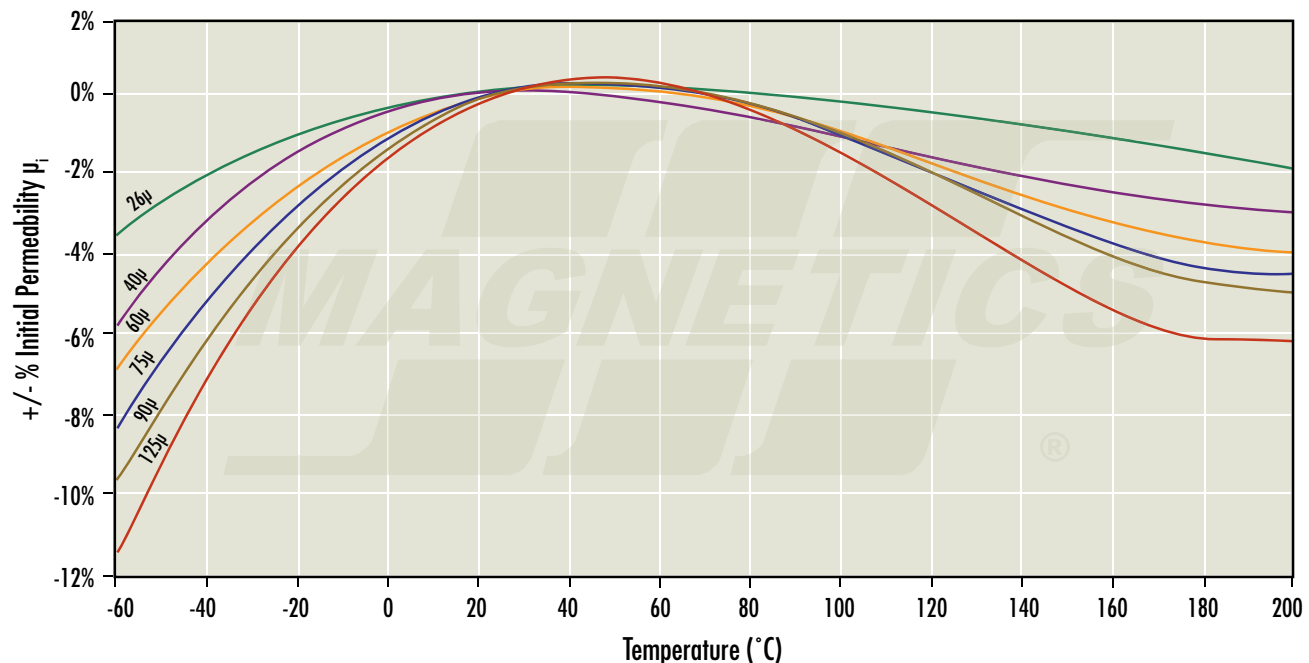

Permeability versus Temperature Curves

XFLUX[®]

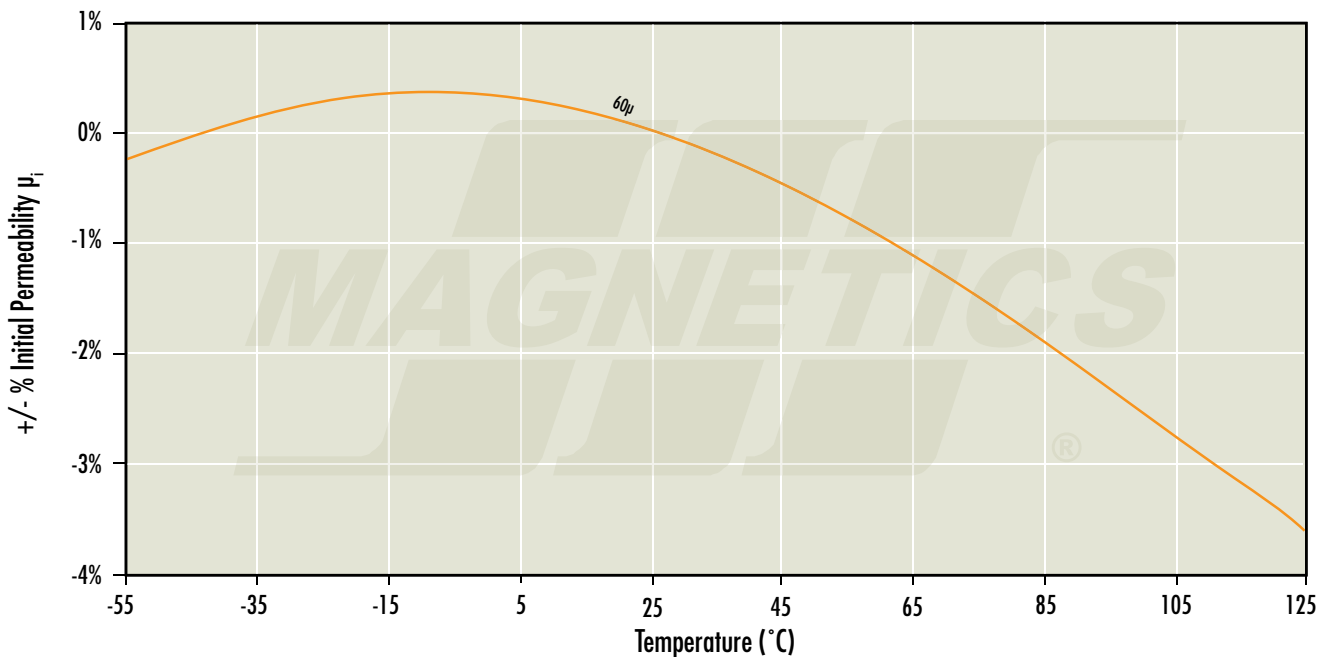

Permeability versus Temperature Curves

Fit Formula (refer to curves for units)

$$\mu \text{ (per unit)} = a + bT + cT^2$$

where:

		a	b	c
MPP	14 μ	-1.300E-03	4.750E-05	1.300E-07
	26 μ	-1.431E-03	5.265E-05	1.837E-07
	60 μ	-1.604E-03	5.945E-05	1.875E-07
	125 μ	-1.939E-03	7.013E-05	2.967E-07
	147 μ	-2.308E-03	8.497E-05	2.943E-07
	160	-2.308E-03	8.497E-05	2.943E-07
	173 μ	-2.308E-03	8.497E-05	2.943E-07
	200 μ	-2.528E-03	9.211E-05	3.601E-07
	300 μ	-2.528E-03	9.211E-05	3.601E-07
High Flux	550 μ	-1.309E-02	4.716E-04	2.086E-06
	14 μ	-2.500E-03	9.670E-05	5.560E-08
	26 μ	-3.300E-03	1.290E-04	3.800E-08
	60 μ	-4.400E-03	1.740E-04	4.090E-08
	125 μ	-6.000E-03	2.400E-04	3.220E-08
	147 μ	-7.900E-03	3.140E-04	7.310E-08
	160 μ	-9.200E-03	3.670E-04	1.750E-08

$$\mu \text{ (per unit)} = a + bT + cT^2 + dT^3 + eT^4$$

where:

		a	b	c	d	e
Kool Mμ[®]	26 μ	-4.289E-03	2.521E-04	-3.557E-06	1.384E-08	-2.066E-11
	40 μ	-5.034E-03	3.521E-04	-6.797E-06	3.193E-08	-4.916E-11
	60 μ	-8.841E-03	5.197E-04	-7.064E-06	1.667E-08	8.820E-12
	75 μ	-1.174E-02	6.653E-04	-8.195E-06	1.411E-08	3.032E-11
	90 μ	-1.369E-02	7.705E-04	-9.385E-06	1.812E-08	2.524E-11
	125 μ	-1.647E-02	9.306E-04	-1.132E-05	1.623E-08	5.722E-11
XFLux[®]	60 μ	3.200E-03	-5.250E-05	-2.830E-06	1.270E-09	3.770E-11

Permeability versus DC Bias Curves

MPP

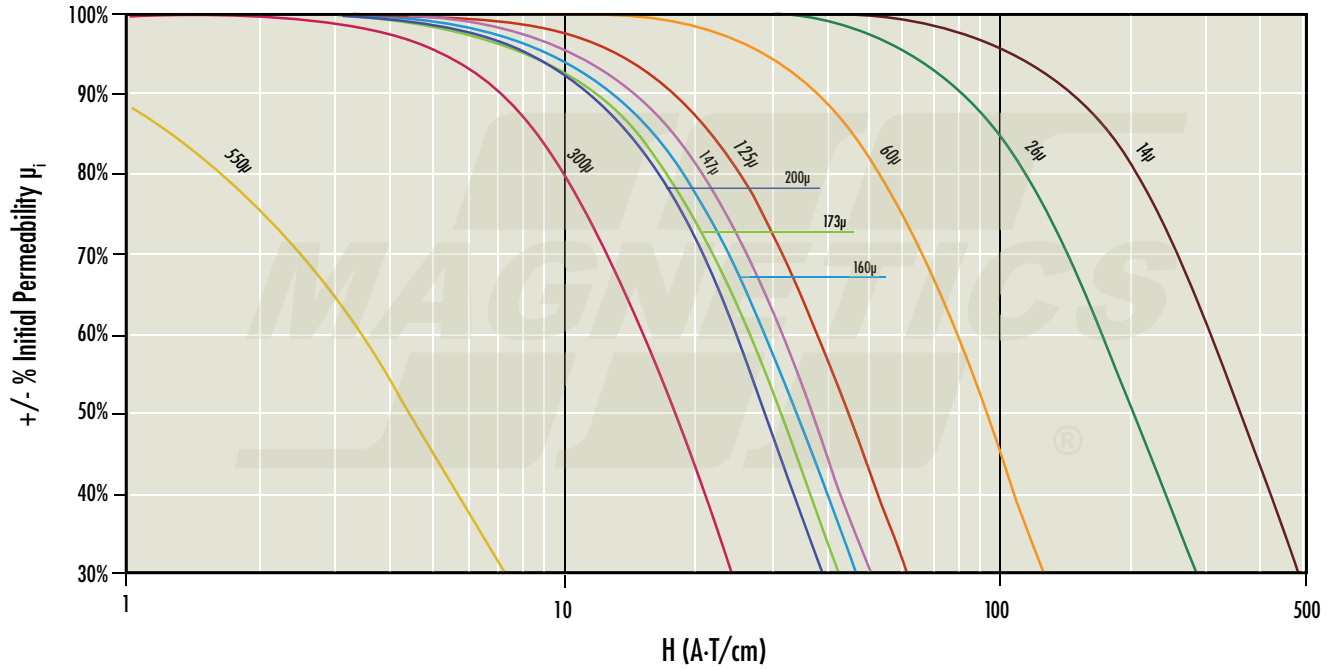

High Flux

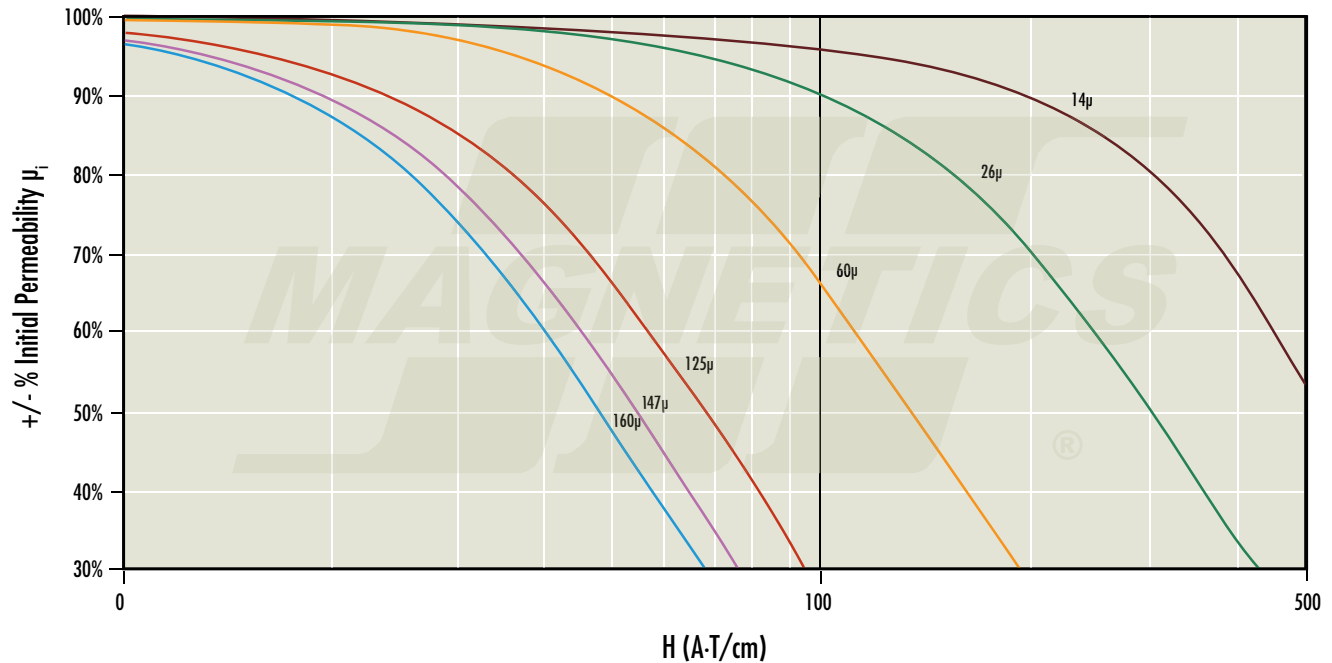

Permeability versus DC Bias Curves

Kool M μ [®]

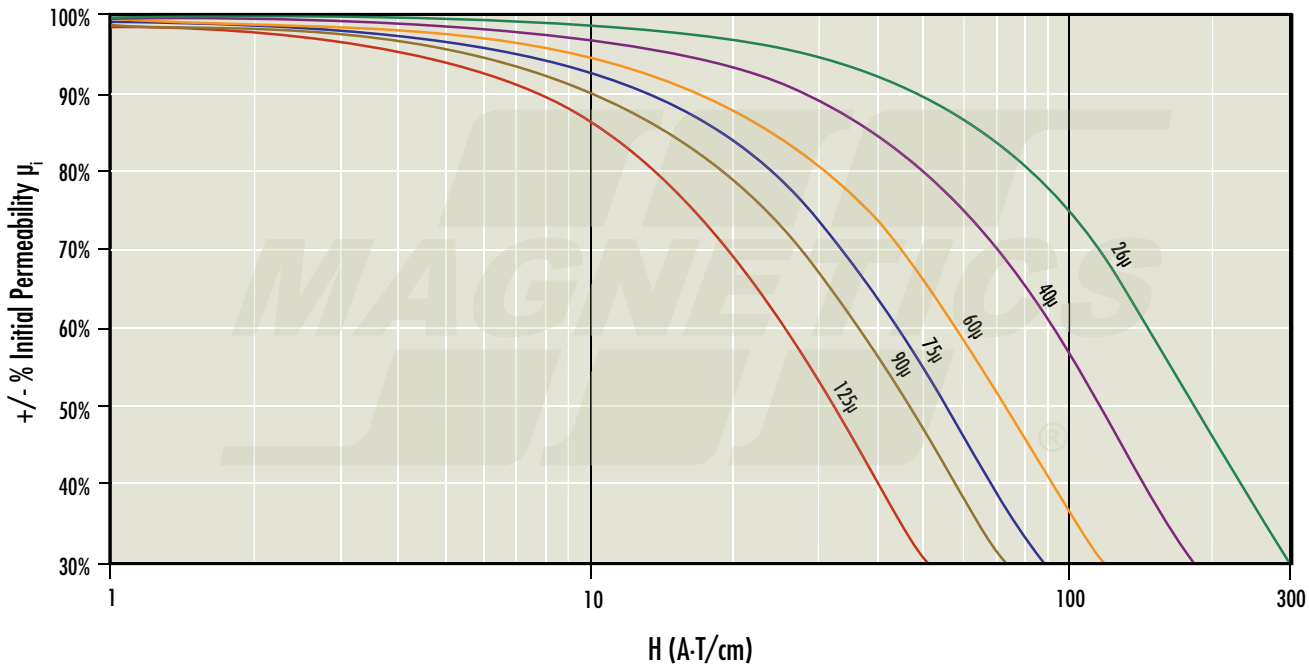

XFLUX[®]

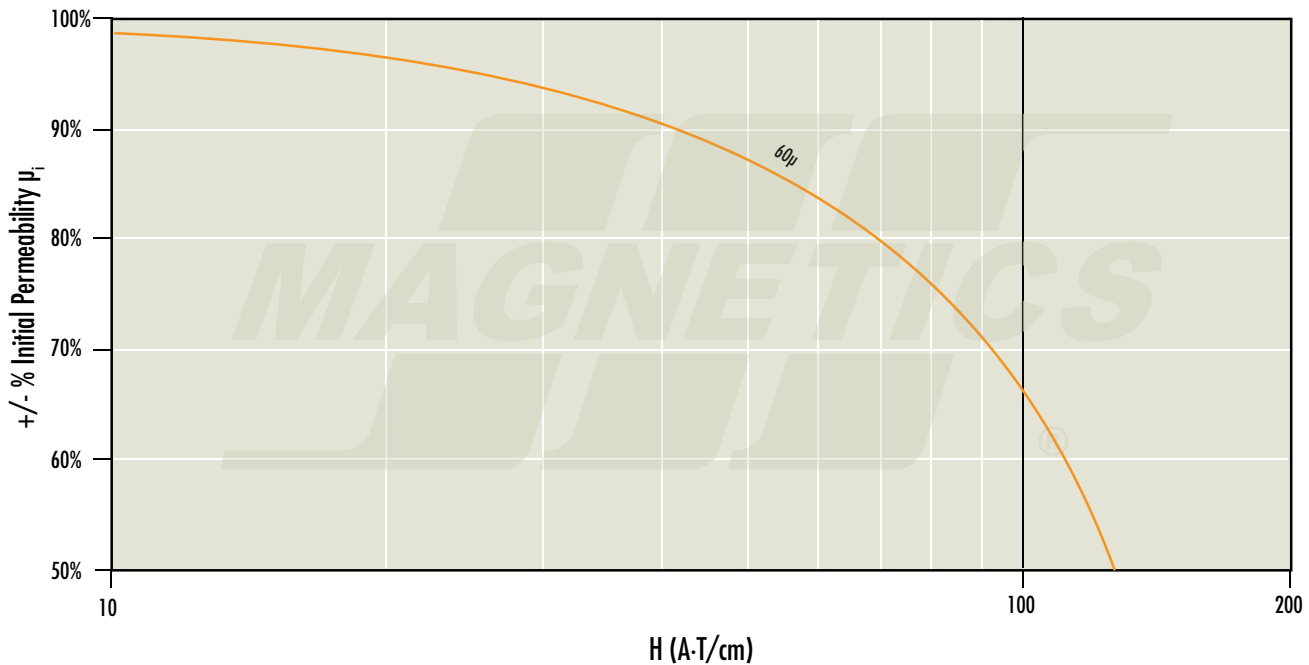

Permeability versus DC Bias Curves

Fit Formula (refer to curves for units)

$$\mu \text{ (per unit)} = a + bT + cT^2 + dT^3 + eT^4$$

where:

		a	b	c	d	e
MPP	14 μ	9.985E-01	4.257E-04	-9.611E-06	1.491E-08	-6.250E-12
	26 μ	9.985E-01	1.142E-03	-3.762E-05	1.222E-07	-1.218E-10
	60 μ	9.971E-01	2.276E-03	-1.623E-04	1.048E-06	-2.013E-09
	125 μ	9.966E-01	3.597E-03	-6.530E-04	8.855E-06	-3.569E-08
	147 μ	9.968E-01	4.036E-03	-9.462E-04	1.560E-05	-7.660E-08
	160 μ	9.973E-01	3.442E-03	-1.060E-03	1.897E-05	-1.004E-07
	173 μ	9.987E-01	2.500E-03	-1.152E-03	2.220E-05	-1.305E-07
	200 μ	9.958E-01	5.128E-03	-1.499E-03	3.055E-05	-1.850E-07
	300 μ	9.942E-01	9.403E-03	-4.140E-03	1.407E-04	-1.425E-06
	550 μ	1.025E+00	-1.462E-01	5.685E-03	1.753E-04	-1.038E-05
High Flux	14 μ	1	-3.954E-04	4.270E-07	-6.515E-09	6.938E-12
	26 μ	1	-8.078E-05	-1.111E-05	2.344E-08	-1.392E-11
	60 μ	1	9.701E-04	-7.570E-05	3.849E-07	-5.977E-10
	125 μ	1	1.236E-04	-2.238E-04	2.065E-06	-5.613E-09
	147 μ	1	3.976E-04	-3.580E-04	4.116E-06	-1.382E-08
	160 μ	1	3.016E-03	-5.897E-04	8.228E-06	-3.502E-08
Kool Mμ[®]	26 μ	1	-1.248E-03	-2.020E-05	8.354E-08	-9.503E-11
	40 μ	1	-2.799E-03	-3.312E-05	2.126E-07	-3.466E-10
	60 μ	1	-4.445E-03	-8.763E-05	9.446E-07	-2.616E-09
	75 μ	1	-6.120E-03	-1.380E-04	1.943E-06	-6.956E-09
	90 μ	1	-9.031E-03	-1.218E-04	2.254E-06	-9.287E-09
	125 μ	1	-9.918E-03	-5.044E-04	1.267E-05	-8.284E-08
XFlux[®]	60 μ	1	-1.200E-03	-3.000E-05	1.000E-07	-1.000E-10

Permeability versus AC Flux Curves

MPP (14 μ - 300 μ)

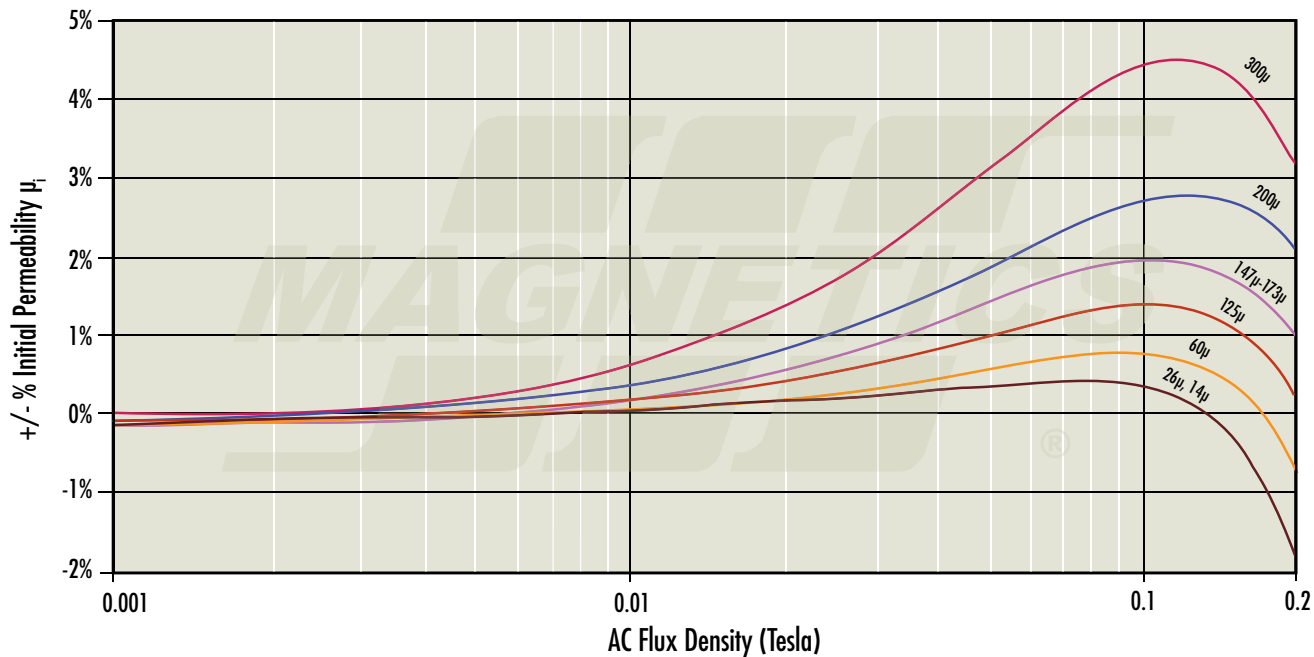

MPP (550 μ)

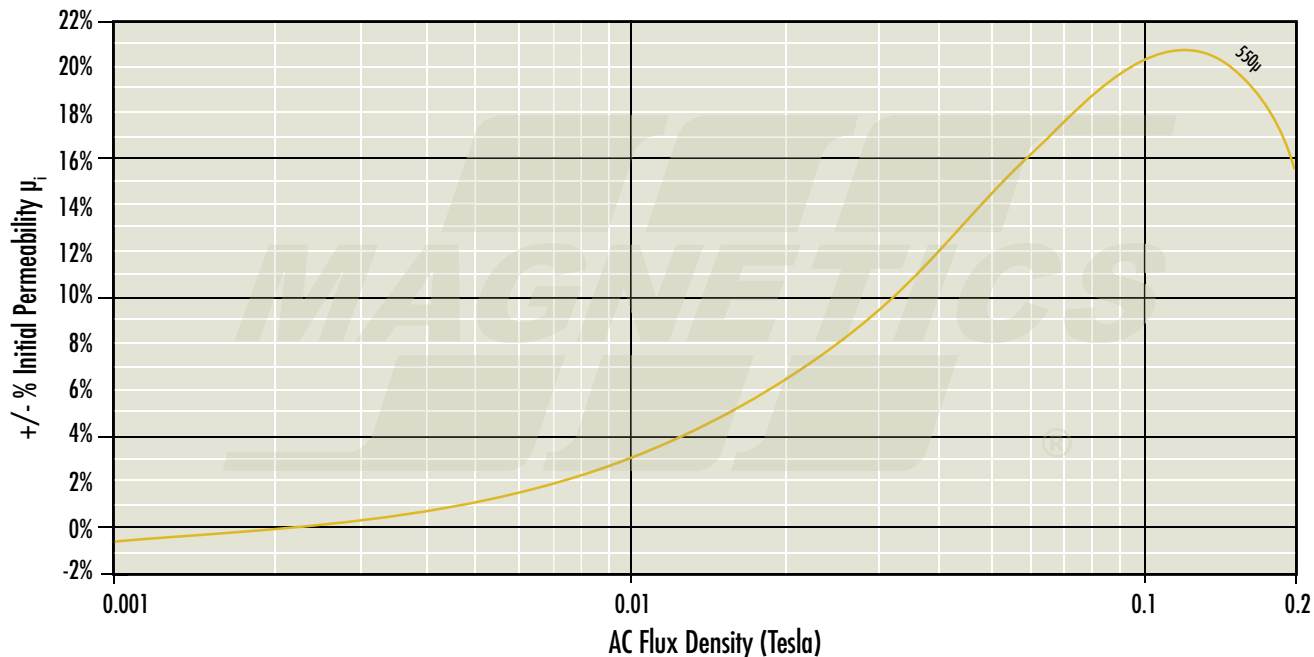

Permeability versus AC Flux Curves

High Flux

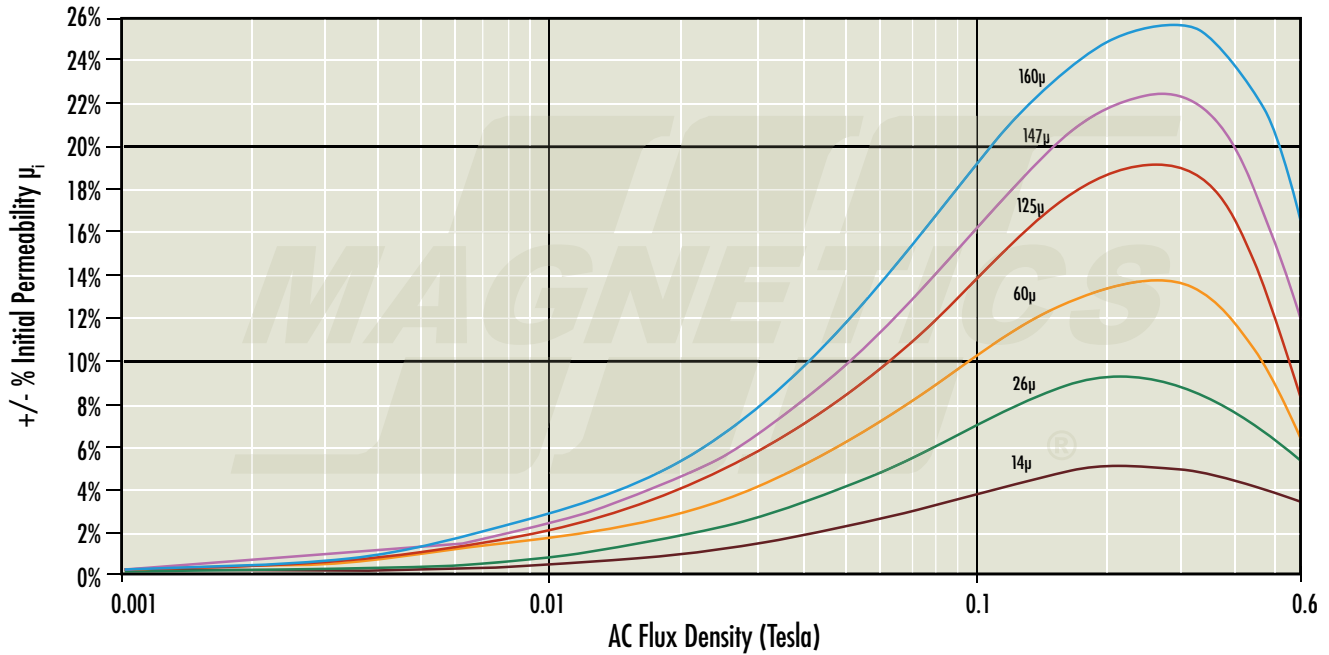

Kool Mμ[®]

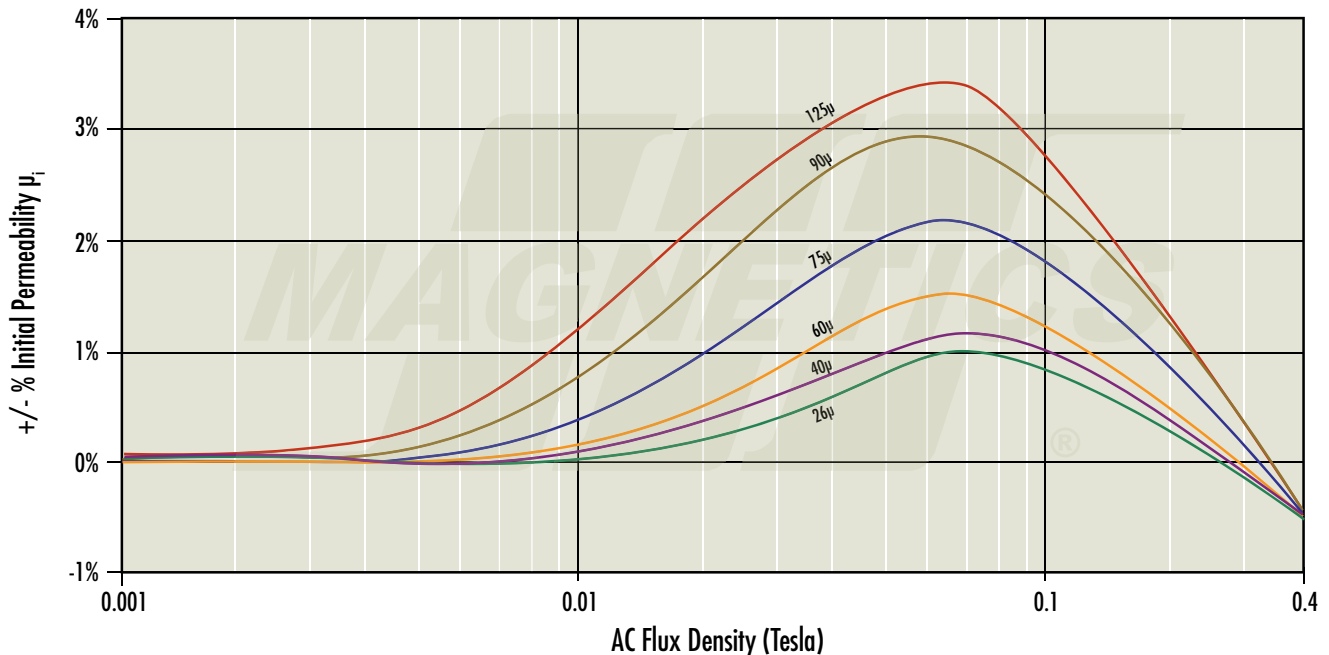

Permeability versus AC Flux Curves

XFLUX[®]

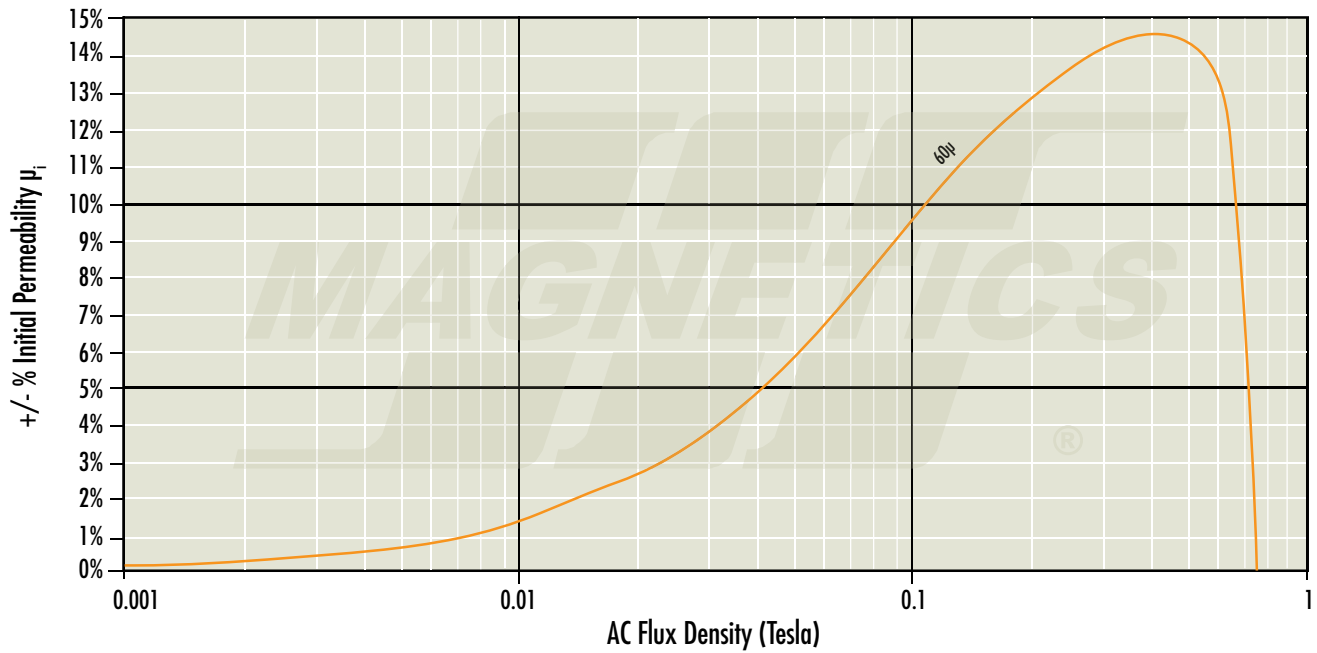

Permeability versus AC Flux Curves

Fit Formula (refer to curves for units)

MPP and High Flux:

$$\mu_{\text{eff}} / \mu_i = (a + bB + cB^2 + dB^3 + eB^4)$$

where:

		a	b	c	d	e
MPP	14μ	-5.000E-04	1.186E-01	-5.096E-01	-2.727E+00	-
	26μ	-5.000E-04	1.186E-01	-5.096E-01	-2.727E+00	-
	60μ	-1.000E-03	1.708E-01	-6.675E-01	-1.792E+00	-
	125μ	-1.000E-03	2.960E-01	-1.561E+00	8.254E-01	-
	147μ	-2.000E-03	4.393E-01	-2.591E+00	3.446E+00	-
	160μ	-2.000E-03	4.393E-01	-2.591E+00	3.446E+00	-
	173μ	-2.000E-03	4.393E-01	-2.591E+00	3.446E+00	-
	200μ	-1.000E-03	5.145E-01	-2.688E+00	3.308E+00	-
	300μ	-2.000E-03	9.038E-01	-5.112E+00	7.055E+00	-
	550μ	-9.000E-03	4.042E+00	-2.240E+01	3.123E+01	-
High Flux	14μ	-1.000E-03	5.458E-01	-1.930E+00	2.598E+00	-1.228E+00
	26μ	-2.000E-03	1.020E+00	-3.696E+00	5.099E+00	-2.529E+00
	60μ	0	1.476E+00	-5.695E+00	9.395E+00	-6.182E+00
	125μ	0	1.934E+00	-6.792E+00	1.014E+01	-6.347E+00
	147μ	0	2.350E+00	-8.895E+00	1.465E+01	-9.716E+00
	160μ	-2.000E-03	2.910E+00	-1.224E+01	2.263E+01	-1.590E+01
Kool M_μ®	26μ	-1.300E-03	4.711E-01	-5.779E+00	2.102E+01	-2.121E+01
	40μ	-2.000E-03	5.866E-01	-7.404E+00	2.883E+01	-3.397E+01
	60μ	-1.900E-03	7.340E-01	-9.824E+00	4.486E+01	-7.157E+01
	75μ	-2.800E-03	1.024E+00	-1.333E+01	5.704E+01	-8.069E+01
	90μ	-2.800E-03	1.430E+00	-2.092E+01	1.115E+02	-2.135E+02
	125μ	-2.400E-03	1.740E+00	-2.662E+01	1.531E+02	-3.170E+02
XFlux®	60μ	0	1.380E+00	-5.300E+00	9.350E+00	-6.250E+00

Permeability versus Frequency Curves

MPP

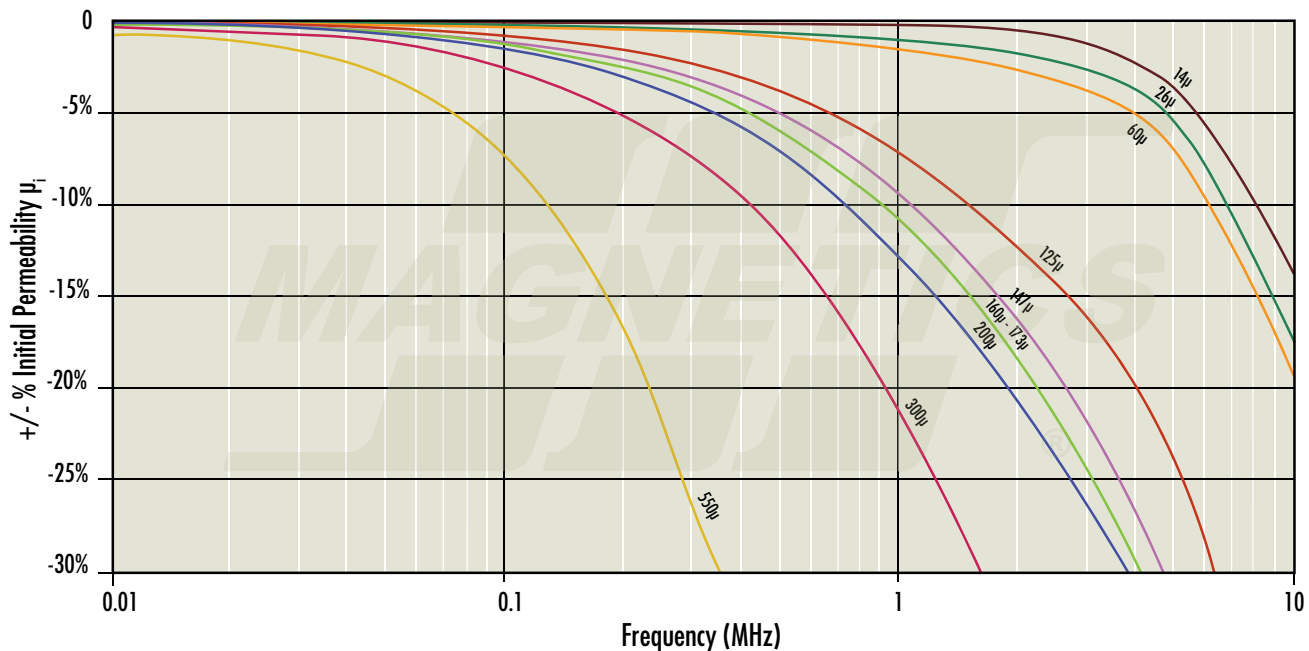

High Flux

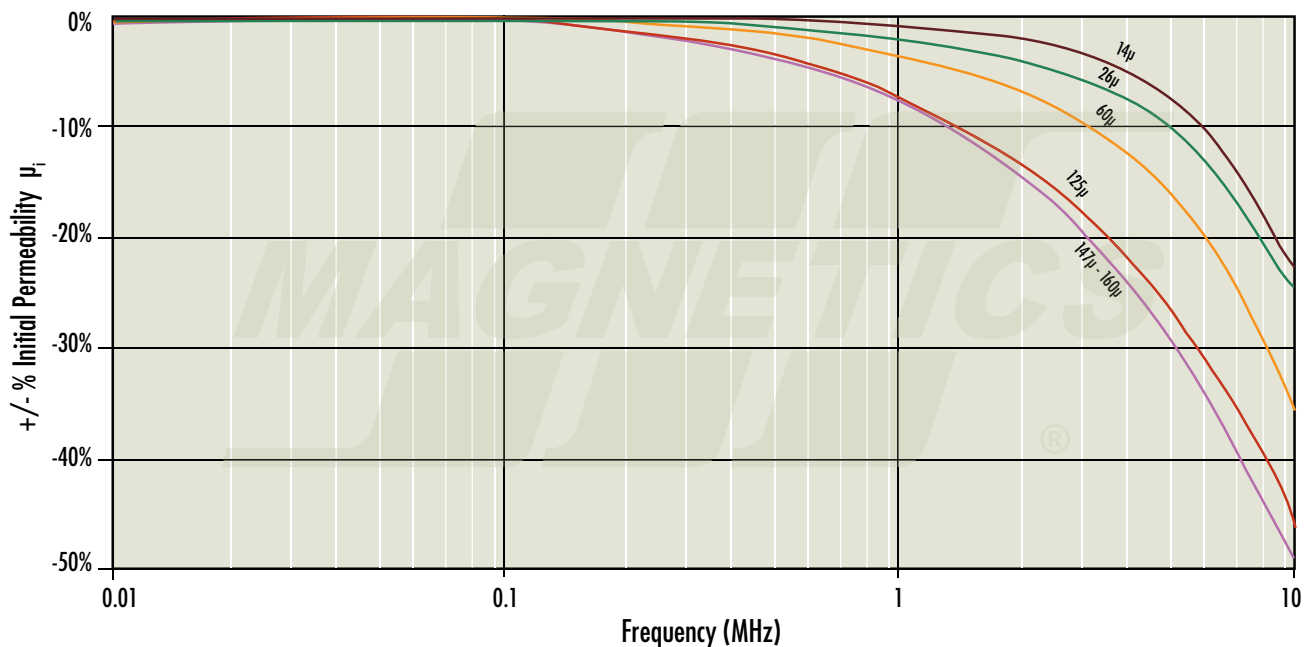

Permeability versus Frequency Curves

Kool M μ [®]

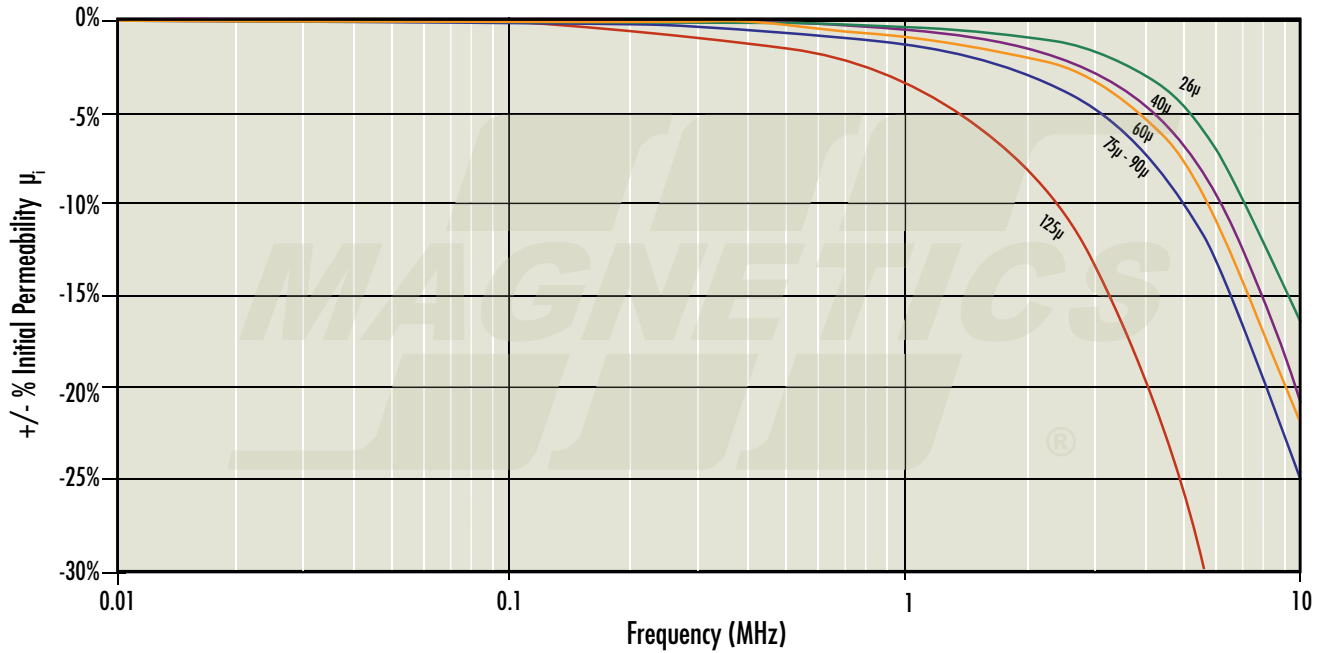

XFLUX[®]

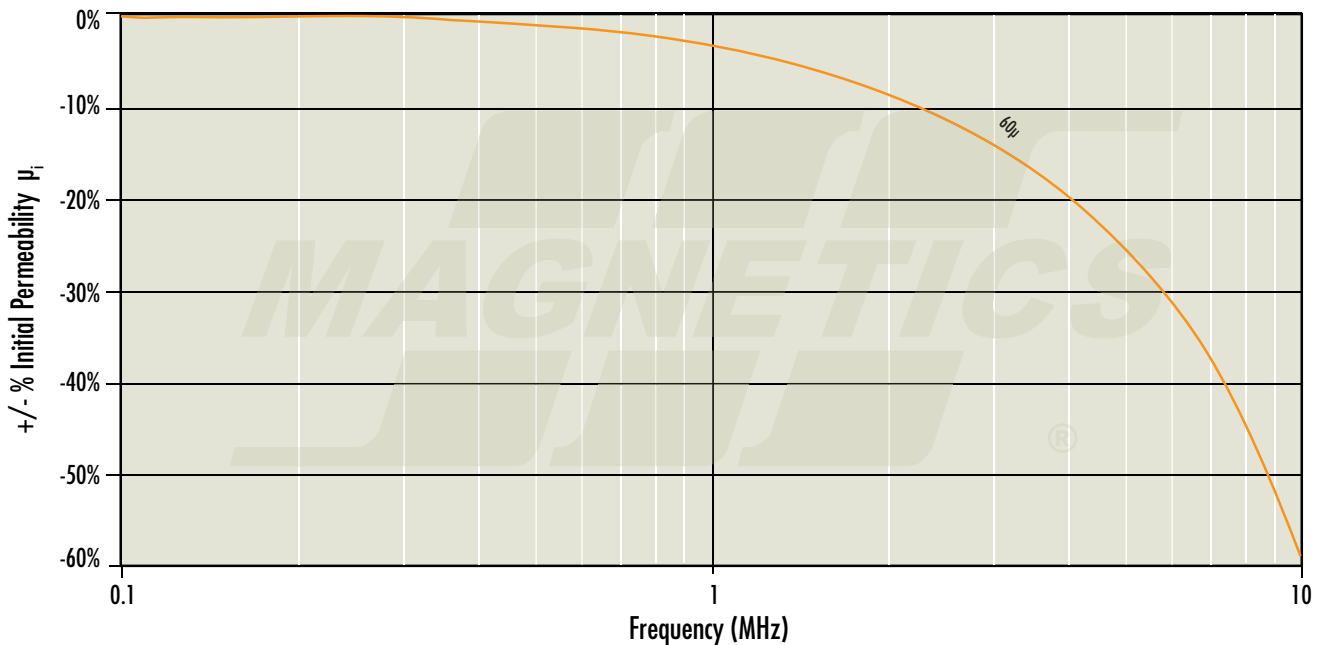

Permeability versus Frequency Curves

Fit Formula (refer to curves for units)

$$\mu \text{ (per unit)} = a + bT + cT^2 + dT^3 + eT^4$$

where:

		a	b	c	d	e
MPP	14 μ	0	-2.320E-03	7.630E-04	-5.070E-04	3.170E-05
	26 μ	0	-1.560E-02	5.190E-03	-1.160E-03	6.230E-05
	60 μ	0	-1.820E-02	4.320E-03	-9.780E-04	5.360E-05
	125 μ	0	-8.430E-02	1.590E-02	-2.270E-03	1.080E-04
	147 μ	0	-1.110E-01	2.040E-02	-2.810E-03	1.300E-04
	160 μ	0	-1.290E-01	2.390E-02	-3.080E-03	1.410E-04
	173 μ	0	-1.290E-01	2.390E-02	-3.080E-03	1.410E-04
	200 μ	0	-1.610E-01	3.820E-02	-5.170E-03	2.160E-04
	300 μ	0	-2.590E-01	5.570E-02	-6.530E-03	2.780E-04
550 μ	0	-4.590E-01	-3.3	8.14	-5.73	
High Flux	14 μ	0	-1.070E-02	5.960E-04	-4.920E-04	3.070E-05
	26 μ	0	-2.560E-02	3.430E-03	-7.340E-04	3.990E-05
	60 μ	0	-3.870E-02	3.050E-03	-5.490E-04	2.690E-05
	125 μ	0	-8.600E-02	1.140E-02	-1.370E-03	6.050E-05
	147 μ	0	-8.170E-02	7.330E-03	-6.400E-04	2.390E-05
	160 μ	0	-8.590E-02	7.220E-03	-5.530E-04	1.880E-05
Kool Mμ[®]	26 μ	0	-5.500E-03	1.400E-03	-6.200E-04	3.700E-05
	40 μ	0	-7.300E-03	8.400E-04	-5.900E-04	3.700E-05
	60 μ	0	-1.100E-02	1.600E-03	-7.100E-04	4.400E-05
	75 μ	0	-2.000E-02	3.500E-03	-9.500E-04	5.500E-05
	90 μ	0	-1.500E-02	6.900E-04	-4.800E-04	3.100E-05
	125 μ	0	-3.000E-02	-5.500E-03	2.400E-04	4.500E-06
XFlux[®]	60 μ	0	-1.090E-01	1.570E-02	-1.640E-03	5.790E-05

Wire Table

AWG Wire Size	Resistance Ω /meter (x.305= Ω /ft)	Wire O.D. (cm) Heavy Build	Wire Area sq. cm ² (x0.001)	Current Capacity, Amps (listed by columns of Amps/cm ²)				
				200	400	500	600	800
6	.00130	.421	139.2	26.6	53.2	66.5	79.8	106
7	.00163	.376	111.0	21.1	42.2	52.8	63.3	84.4
8	.00206	.336	88.7	16.7	33.5	41.8	50.2	66.9
9	.00260	.299	70.2	13.3	26.5	33.2	39.8	53.1
10	.00328	.267	56.0	10.5	21.0	26.3	31.6	42.1
11	.00414	.238	44.5	8.34	16.7	20.8	25.0	33.3
12	.00521	.213	35.6	6.62	13.2	16.5	19.8	26.5
13	.00656	.1902	28.4	5.25	10.5	13.1	15.8	21.0
14	.00828	.1715	23.1	4.16	8.33	10.4	12.5	16.7
15	.01044	.1529	18.4	3.30	6.61	8.26	9.91	13.2
16	.01319	.1369	14.72	2.62	5.23	6.54	7.85	10.5
17	.01658	.1224	11.77	2.08	4.16	5.20	6.24	8.32
18	.02095	.1095	9.42	1.65	3.29	4.11	4.94	6.58
19	.02640	.098	7.54	1.31	2.61	3.27	3.92	5.22
20	.03323	.0879	6.07	1.04	2.08	2.59	3.11	4.15
21	.04190	.0785	4.84	0.823	1.65	2.06	2.47	3.29
22	.05315	.0701	3.86	0.649	1.30	1.62	1.95	2.59
23	.06663	.0632	3.14	0.518	1.04	1.29	1.55	2.07
24	.08422	.0566	2.52	0.409	0.819	1.0236	1.23	1.64
25	.10620	.0505	2.00	0.325	0.649	0.812	0.974	1.30
26	.13458	.0452	1.60	0.256	0.512	0.641	0.769	1.02
27	.16873	.0409	1.31	0.204	0.409	0.511	0.613	0.817
28	0.214	.0366	1.05	0.161	0.322	0.402	0.483	0.644
29	0.266	.033	.855	0.129	0.259	0.324	0.388	0.518
30	0.340	.0295	.683	0.101	0.203	0.253	0.304	0.405
31	0.429	.0267	.560	0.0803	0.161	0.201	0.241	0.321
32	0.532	.0241	.456	0.0649	0.130	0.162	0.195	0.259
33	0.675	.0216	.366	0.0511	0.102	0.128	0.153	0.204
34	0.857	.01905	.285	0.0402	0.0804	0.101	0.121	0.161
35	1.085	.01702	.228	0.0318	0.0636	0.0795	0.0953	0.127
36	1.361	.01524	.182	0.0253	0.0507	0.0633	0.0760	0.101
37	1.680	.01397	.153	0.0205	0.0410	0.0513	0.0616	0.0821
38	2.13	.01245	.122	0.0162	0.0324	0.0405	0.0486	0.0649
39	2.78	.01092	.094	0.0124	0.0248	0.0310	0.0372	0.0497
40	3.54	.00965	.073	0.00974	0.0195	0.0243	0.0292	0.0390
41	4.34	.00864	.059	0.00795	0.0159	0.0199	0.0238	0.0318
42	5.44	.00762	.046	0.00633	0.0127	0.0158	0.0190	0.0253
43	7.03	.00686	.037	0.00490	0.00981	0.0123	0.0147	0.0196
44	8.51	.00635	.032	0.00405	0.00811	0.0101	0.0122	0.0162
45	10.98	.00546	.023	0.00314	0.00628	0.00785	0.00942	0.0126
46	13.80	.00498	.019	0.00250	0.00500	0.00624	0.00749	0.00999
47	17.36	.00452	.016	0.00199	0.00397	0.00497	0.00596	0.00795
48	22.1	.00394	.012	0.00156	0.00312	0.00390	0.00467	0.00623
49	27.6	.00353	.010	0.00125	0.00250	0.00312	0.00375	0.00499

Notes



3.56 mm OD

Core Dimensions	OD(max)	ID(min)	HT(max)
Before Finish (nominal)	3.56 mm/0.140 in	1.78 mm/0.070 in	1.52 mm/0.060 in
After Finish (limits)	4.20 mm/0.165 in	1.27 mm/0.050 in	2.16 mm/0.085 in

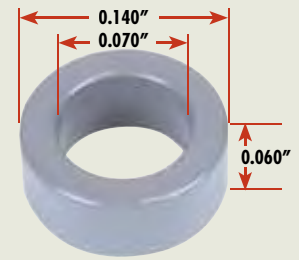

Permeability (μ)	$A_L \pm 8\%$ Kool M μ $A_L \pm 15\%$	Part Number			
		MPP	High Flux	Kool M μ [®]	XFLUX [®]
60	13	-	-	77141	-
75	16	-	-	77445	-
90	19	-	-	77444	-
125	26	55140	-	77140	-
147	31	55139	-	-	-
160	33	55138	-	-	-
173	36	55134	-	-	-
200	42	55137	-	-	-
300	62	55135	-	-	-

Physical Characteristics	
Window Area	1.27 mm ²
Cross Section	1.30 mm ²
Path Length	8.06 mm
Volume	10.5 mm ³
Weight- MPP	0.094 g
Weight- High Flux	-
Weight- Kool M μ	0.065 g
Weight - XFLUX	-
Area Product	1.65 mm ⁴

Wound Coil Dimensions	
Max OD (70%)	4.95 mm
Max HT (70%)	2.74 mm

Winding Turn Length * Reference General Winding Data pages	
WINDING FACTOR	LENGTH/TURN (mm)
0%	7.24
20%	7.56
25%	7.65
30%	7.70
35%	7.81
40%	7.89
45%	7.98
50%	8.08
60%	8.27
70%	8.48

Surface Area	
Unwound Core	48.4 mm ²
40% Winding Factor	65.2 mm ²

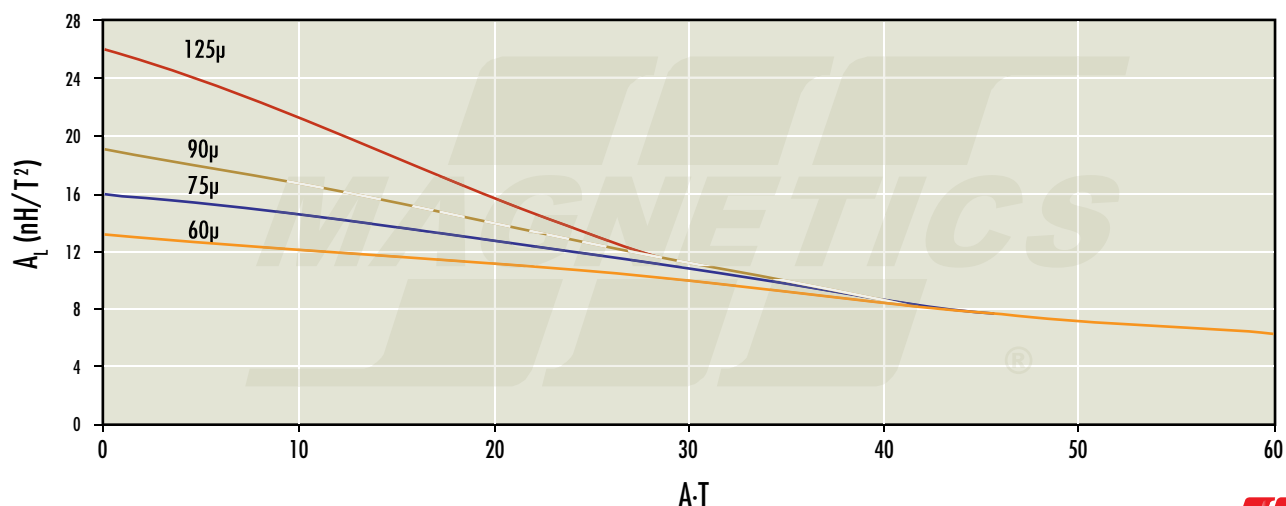
Kool M μ A_L vs. DC Bias

3.94 mm OD

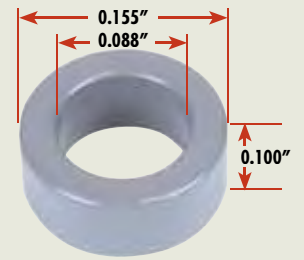

Core Data

Core Dimensions	OD(max)	ID(min)	HT(max)
Before Finish (nominal)	3.94 mm/0.155 in	2.24 mm/0.088 in	2.54 mm/0.100 in
After Finish (limits)	4.58 mm/0.180 in	1.72 mm/0.068 in	3.18 mm/0.125 in

Permeability (μ)	$A_L \pm 8\%$ Kool M μ $A_L \pm 15\%$	Part Number			
		MPP	High Flux	Kool M μ [®]	XFLUX [®]
60	17	-	-	77151	-
75	21	-	-	77155	-
90	25	-	-	77154	-
125	35	55150	-	77150	-
147	41	55149	-	-	-
160	45	55148	-	-	-
173	48	55144	-	-	-
200	56	55147	-	-	-
300	84	55145	-	-	-

Physical Characteristics	
Window Area	2.32 mm ²
Cross Section	2.11 mm ²
Path Length	9.42 mm
Volume	19.9 mm ³
Weight- MPP	0.17 g
Weight- High Flux	-
Weight- Kool M μ	0.12 g
Weight - XFLUX	-
Area Product	4.90 mm ⁴

Winding Turn Length * Reference General Winding Data pages	
WINDING FACTOR	LENGTH/TURN (mm)
0%	9.20
20%	9.64
25%	9.76
30%	9.84
35%	9.98
40%	10.1
45%	10.2
50%	10.3
60%	10.6
70%	10.9

Wound Coil Dimensions	
Max OD (70%)	5.77 mm
Max HT (70%)	4.75 mm

Surface Area	
Unwound Core	76.1 mm ²
40% Winding Factor	120 mm ²

Kool M μ A_L vs. DC Bias

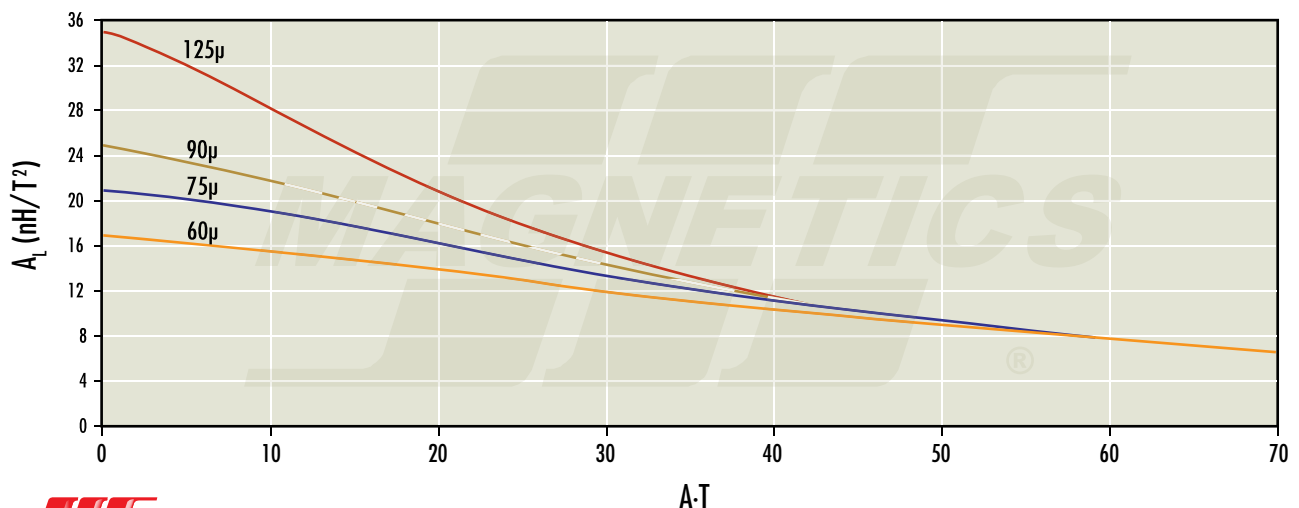

4.65 mm OD

Core Dimensions	OD(max)	ID(min)	HT(max)
Before Finish (nominal)	4.65 mm/0.183 in	2.36 mm/0.093 in	2.54 mm/0.100 in
After Finish (limits)	5.29 mm/0.208 in	1.85 mm/0.073 in	3.18 mm/0.125 in

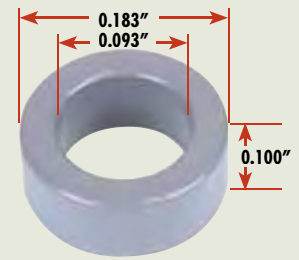

Permeability (μ)	$A_L \pm 8\%$ Kool M μ $A_L \pm 15\%$	Part Number			
		MPP	High Flux	Kool M μ [®]	XFLUX [®]
60	20	55181	-	77181	-
75	25	-	-	77185	-
90	30	-	-	77184	-
125	42	55180	-	77180	-
147	49	55179	-	-	-
160	53	55178	-	-	-
173	57	55174	-	-	-
200	67	55177	-	-	-
300	99	55175	-	-	-

Physical Characteristics	
Window Area	2.69 mm ²
Cross Section	2.85 mm ²
Path Length	10.6 mm
Volume	30.3 mm ³
Weight- MPP	0.25 g
Weight- High Flux	-
Weight- Kool M μ	0.18 g
Weight - XFLUX	-
Area Product	7.66 mm ⁴

Wound Coil Dimensions	
Max OD (70%)	6.65 mm
Max HT (70%)	4.94 mm

Winding Turn Length <small>* Reference General Winding Data pages</small>	
WINDING FACTOR	LENGTH/TURN (mm)
0%	9.79
20%	10.3
25%	10.4
30%	10.5
35%	10.6
40%	10.7
45%	10.9
50%	11.0
60%	11.3
70%	11.6

Surface Area	
Unwound Core	111 mm ²
40% Winding Factor	150 mm ²

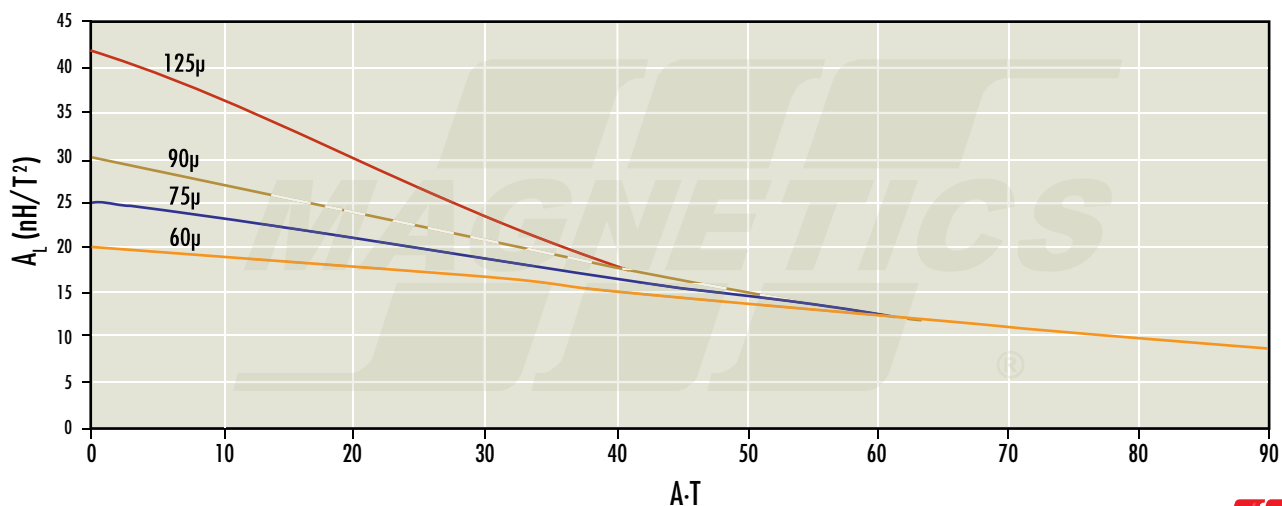
Kool M μ A_L vs. DC Bias

6.35 mm OD

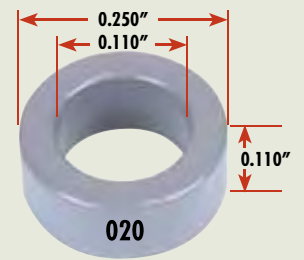

Core Dimensions	OD(max)	ID(min)	HT(max)
Before Finish (nominal)	6.35 mm/0.250 in	2.79 mm/0.110 in	2.79 mm/0.110 in
After Finish (limits)	6.99 mm/0.275 in	2.28 mm/0.090 in	3.43 mm/0.135 in

Permeability (μ)	$A_L \pm 8\%$ Kool M μ $A_L \pm 12\%$	Part Number			
		MPP	High Flux	Kool M μ [®]	XFLUX [®]
14	6	55023	58023	-	-
26	10	55022	58022	-	-
60	24	55021	58021	77021	-
75	30	-	-	77825	-
90	36	-	-	77824	-
125	50	55020	58020	77020	-
147	59	55019	58019	-	-
160	64	55018	58018	-	-
173	69	55014	-	-	-
200	80	55017	-	-	-
300	120	55015	-	-	-
550	220	55016	-	-	-

Physical Characteristics	
Window Area	4.08 mm ²
Cross Section	4.70 mm ²
Path Length	13.6 mm
Volume	64.0 mm ³
Weight- MPP	0.59 g
Weight- High Flux	0.55 g
Weight- Kool M μ	0.39 g
Weight - XFLux	-
Area Product	19.2 mm ⁴

Winding Turn Length * Reference General Winding Data pages	
WINDING FACTOR	LENGTH/TURN (mm)
0%	11.6
20%	12.2
25%	12.3
30%	12.4
35%	12.6
40%	12.8
45%	12.9
50%	13.1
60%	13.4
70%	13.9

Wound Coil Dimensions	
Max OD (70%)	8.81 mm
Max HT (70%)	5.38 mm

Surface Area	
Unwound Core	168 mm ²
40% Winding Factor	220 mm ²

Kool M μ A_L vs. DC Bias

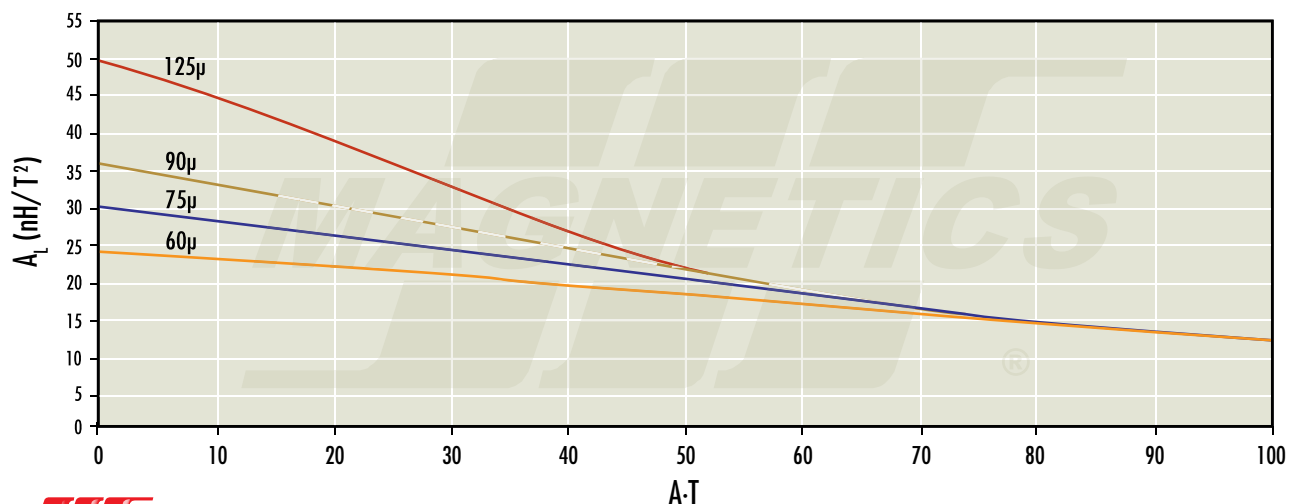

6.60 mm OD

Core Dimensions	OD(max)	ID(min)	HT(max)
Before Finish (nominal)	6.60 mm/0.260 in	2.67 mm/0.105 in	2.54 mm/0.100 in
After Finish (limits)	7.24 mm/0.285 in	2.15 mm/0.085 in	3.18 mm/0.125 in

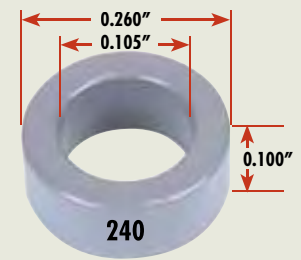

Permeability (μ)	$A_L \pm 8\%$ Kool M μ $A_L \pm 12\%$	Part Number			
		MPP	High Flux	Kool M μ [®]	XFLUX [®]
14	6	55243	58243	-	-
26	11	55242	58242	-	-
60	26	55241	58241	77241	-
75	32	-	-	77245	-
90	39	-	-	77244	-
125	54	55240	58240	77240	-
147	64	55239	58239	-	-
160	69	55238	58238	-	-
173	75	55234	-	-	-
200	86	55237	-	-	-
300	130	55235	-	-	-
550	242	55236	-	-	-

Physical Characteristics	
Window Area	3.63 mm ²
Cross Section	4.76 mm ²
Path Length	13.6 mm
Volume	64.9 mm ³
Weight- MPP	0.58 g
Weight- High Flux	0.55 g
Weight- Kool M μ	0.40 g
Weight - XFLUX	-
Area Product	17.3 mm ⁴

Wound Coil Dimensions	
Max OD (70%)	9.12 mm
Max HT (70%)	5.13 mm

Winding Turn Length * Reference General Winding Data pages	
WINDING FACTOR	LENGTH/TURN (mm)
0%	11.4
20%	12.0
25%	12.2
30%	12.3
35%	12.4
40%	12.6
45%	12.7
50%	12.9
60%	13.2
70%	13.6

Surface Area	
Unwound Core	170 mm ²
40% Winding Factor	230 mm ²

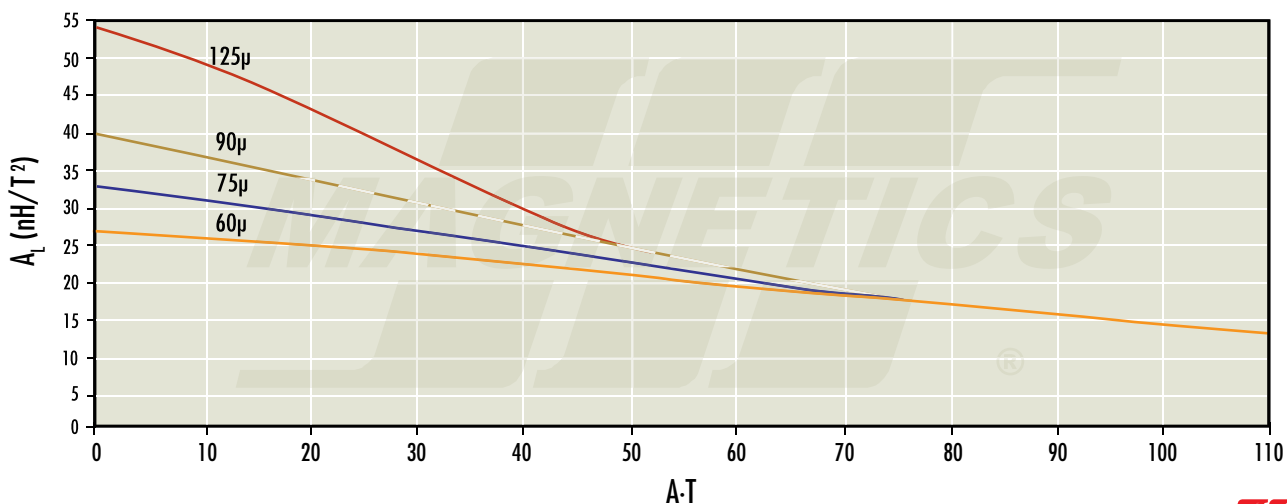
Kool M μ A_L vs. DC Bias

6.60 mm OD

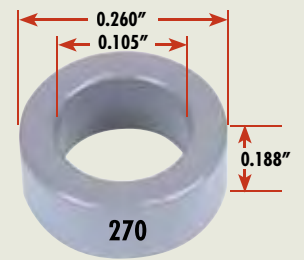

Core Dimensions	OD(max)	ID(min)	HT(max)
Before Finish (nominal)	6.60 mm/0.260 in	2.67 mm/0.105 in	4.78 mm/0.188 in
After Finish (limits)	7.24 mm/0.285 in	2.15 mm/0.085 in	5.42 mm/0.213 in

Permeability (μ)	$A_L \pm 8\%$ Kool M μ $A_L \pm 12\%$	Part Number			
		MPP	High Flux	Kool M μ [®]	XFLUX [®]
14	12	55273	58273	-	-
26	21	55272	58272	-	-
60	50	55271	58271	77271	-
75	62	-	-	77875	-
90	74	-	-	77874	-
125	103	55270	58270	77270	-
147	122	55269	58269	-	-
160	132	55268	58268	-	-
173	144	55264	-	-	-
200	165	55267	-	-	-
300	247	55265	-	-	-
550	466	55266	-	-	-

Physical Characteristics	
Window Area	3.63 mm ²
Cross Section	9.20 mm ²
Path Length	13.6 mm
Volume	125 mm ³
Weight- MPP	1.1 g
Weight- High Flux	1.0 g
Weight- Kool M μ	0.77 g
Weight - XFLUX	-
Area Product	33.4 mm ⁴

Winding Turn Length * Reference General Winding Data pages	
WINDING FACTOR	LENGTH/TURN (mm)
0%	16.2
20%	16.7
25%	16.9
30%	17.0
35%	17.1
40%	17.3
45%	17.4
50%	17.6
60%	17.9
70%	18.3

Wound Coil Dimensions	
Max OD (70%)	9.17 mm
Max HT (70%)	7.42 mm

Surface Area	
Unwound Core	242 mm ²
40% Winding Factor	290 mm ²

Kool M μ A_L vs. DC Bias

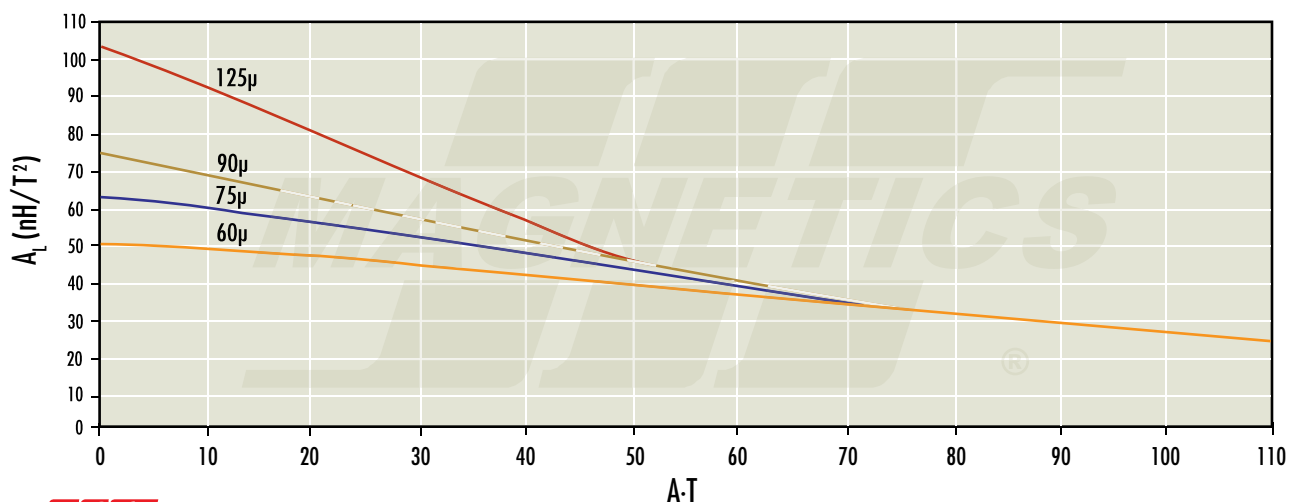

6.86 mm OD

Core Dimensions	OD(max)	ID(min)	HT(max)
Before Finish (nominal)	6.86 mm/0.270 in	3.96 mm/0.156 in	5.08 mm/0.200 in
After Finish (limits)	7.50 mm/0.295 in	3.45 mm/0.136 in	5.72 mm/0.225 in

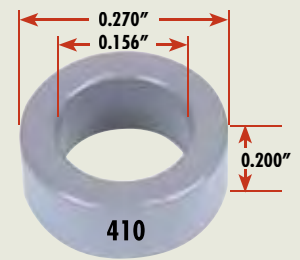

Permeability (μ)	$A_L \pm 8\%$ Kool M μ $A_L \pm 12\%$	Part Number			
		MPP	High Flux	Kool M μ [®]	XFLUX [®]
14	8	55413	58413	-	-
26	14	55412	58412	-	-
60	33	55411	58411	77411	-
75	42	-	-	77415	-
90	50	-	-	77414	-
125	70	55410	58410	77410	-
147	81	55409	58409	-	-
160	89	55408	58408	-	-
173	95	55404	-	-	-
200	112	55407	-	-	-
300	166	55405	-	-	-

Physical Characteristics	
Window Area	9.35 mm ²
Cross Section	7.25 mm ²
Path Length	16.5 mm
Volume	120 mm ³
Weight- MPP	1.0 g
Weight- High Flux	0.94 g
Weight- Kool M μ	0.74 g
Weight - XFLUX	-
Area Product	67.8 mm ⁴

Wound Coil Dimensions	
Max OD (70%)	9.60 mm
Max HT (70%)	10.0 mm

Winding Turn Length * Reference General Winding Data pages	
WINDING FACTOR	LENGTH/TURN (mm)
0%	15.5
20%	16.4
25%	16.6
30%	16.8
35%	17.0
40%	17.3
45%	17.5
50%	17.8
60%	18.3
70%	18.9

Surface Area	
Unwound Core	270 mm ²
40% Winding Factor	320 mm ²

Kool M μ A_L vs. DC Bias

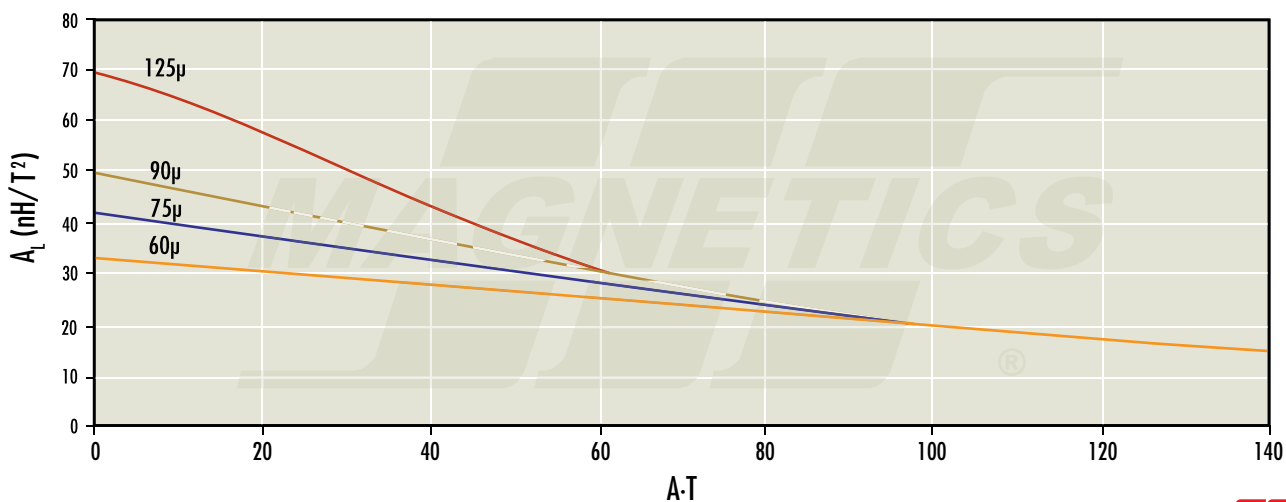

7.87 mm OD

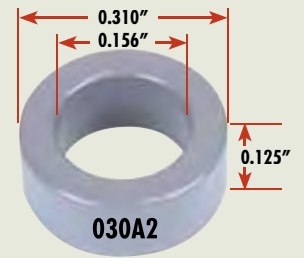

Core Dimensions	OD(max)	ID(min)	HT(max)
Before Finish (nominal)	7.87 mm/0.310 in	3.96 mm/0.156 in	3.18 mm/0.125 in
After Finish (limits)	8.51 mm/0.335 in	3.45 mm/0.136 in	3.81 mm/0.150 in

Permeability (μ)	$A_L \pm 8\%$ Kool M μ $A_L \pm 12\%$	Part Number			
		MPP	High Flux	Kool M μ [®]	XFLUX [®]
14	6	55033	58033	-	-
26	11	55032	58032	-	-
60	25	55031	58031	77031	-
75	31	-	-	77835	-
90	37	-	-	77834	-
125	52	55030	58030	77030	-
147	62	55029	58029	-	-
160	66	55028	58028	-	-
173	73	55024	-	-	-
200	83	55027	-	-	-
300	124	55025	-	-	-
550	229	55026	-	-	-

Physical Characteristics	
Window Area	9.35 mm ²
Cross Section	5.99 mm ²
Path Length	17.9 mm
Volume	107 mm ³
Weight- MPP	0.92 g
Weight- High Flux	0.87 g
Weight- Kool M μ	0.68 g
Weight - XFLUX	-
Area Product	56.0 mm ⁴

Winding Turn Length * Reference General Winding Data pages	
WINDING FACTOR	LENGTH/TURN (mm)
0%	12.7
20%	13.6
25%	13.8
30%	14.0
35%	14.3
40%	14.5
45%	14.7
50%	15.0
60%	15.5
70%	16.1

Wound Coil Dimensions	
Max OD (70%)	11.0 mm
Max HT (70%)	6.73 mm

Surface Area	
Unwound Core	238 mm ²
40% Winding Factor	320 mm ²

Kool M μ A_L vs. DC Bias

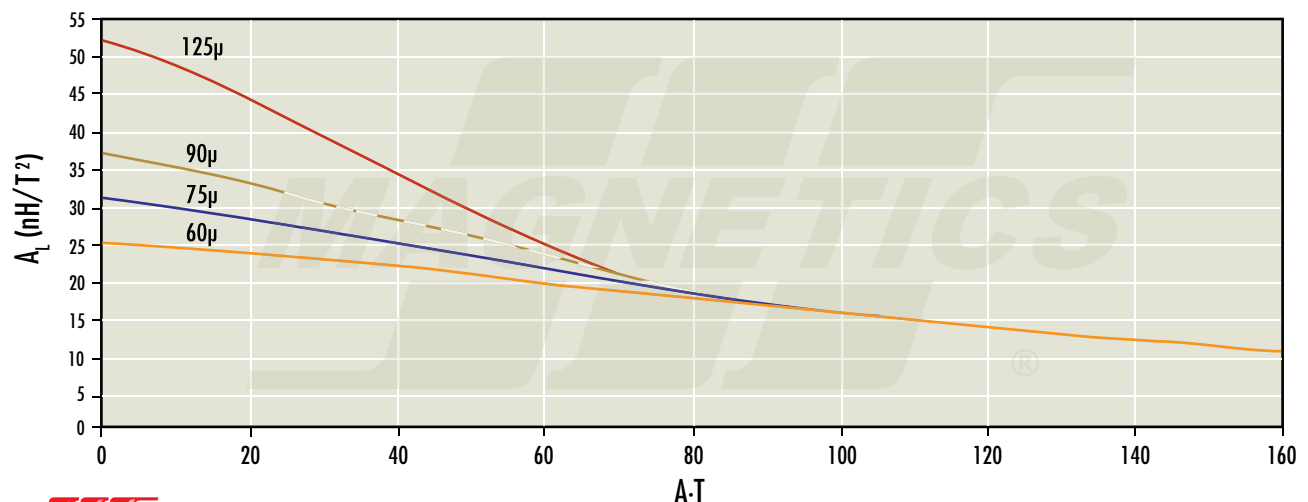

9.65 mm OD

Core Dimensions	OD(max)	ID(min)	HT(max)
Before Finish (nominal)	9.65 mm/0.380 in	4.78 mm/0.188 in	3.18 mm/0.125 in
After Finish (limits)	10.3 mm/0.405 in	4.26 mm/0.168 in	3.81 mm/0.150 in

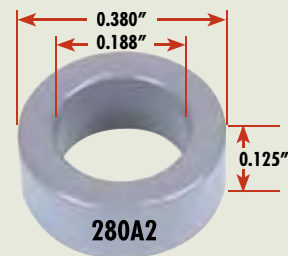

Permeability (μ)	$A_L \pm 8\%$ Kool M μ $A_L \pm 12\%$	Part Number			
		MPP	High Flux	Kool M μ [®]	XFLUX [®]
14	6	55283	58283	-	-
26	11	55282	58282	-	-
60	25	55281	58281	77281	-
75	32	-	-	77885	-
90	38	-	-	77884	-
125	53	55280	58280	77280	-
147	63	55279	58279	-	-
160	68	55278	58278	-	-
173	74	55274	-	-	-
200	84	55277	-	-	-
300	128	55275	-	-	-
550	232	55276	-	-	-

Physical Characteristics	
Window Area	14.3 mm ²
Cross Section	7.52 mm ²
Path Length	21.8 mm
Volume	164 mm ³
Weight- MPP	1.4 g
Weight- High Flux	1.3 g
Weight- Kool M μ	1.0 g
Weight - XFLUX	-
Area Product	107 mm ⁴

Wound Coil Dimensions	
Max OD (70%)	13.4 mm
Max HT (70%)	7.44 mm

Winding Turn Length <small>* Reference General Winding Data pages</small>	
WINDING FACTOR	LENGTH/TURN (mm)
0%	13.6
20%	14.7
25%	15.0
30%	15.3
35%	15.6
40%	15.9
45%	16.2
50%	16.5
60%	17.2
70%	17.9

Surface Area	
Unwound Core	312 mm ²
40% Winding Factor	440 mm ²

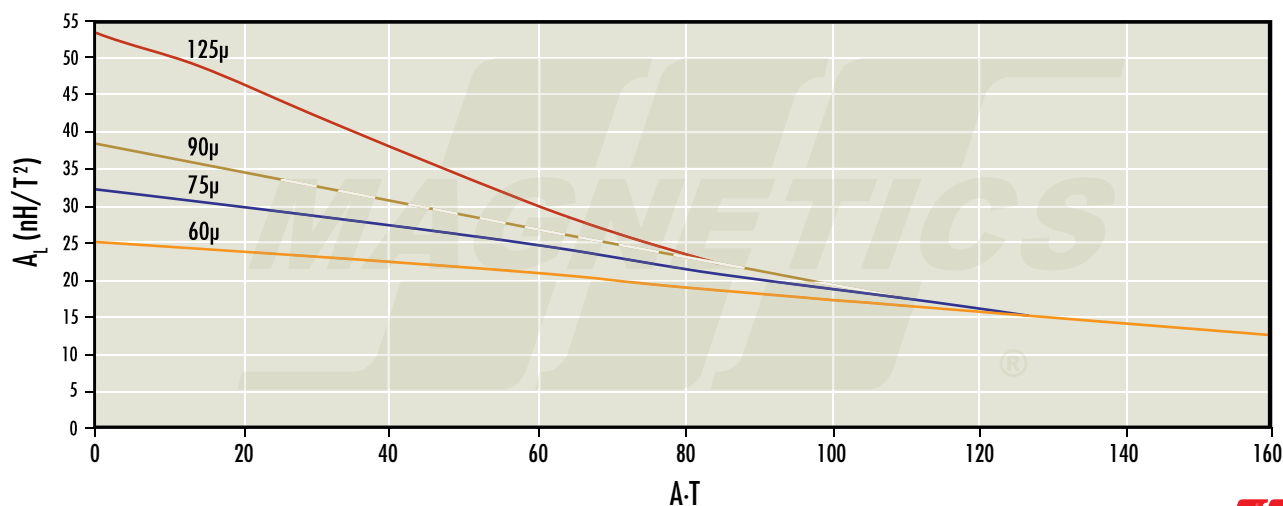
Kool M μ A_L vs. DC Bias

9.65 mm OD

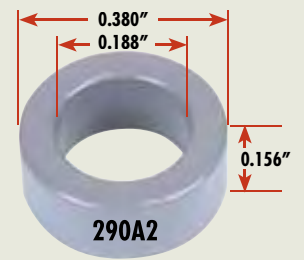

Core Dimensions	OD(max)	ID(min)	HT(max)
Before Finish (nominal)	9.65 mm/0.380 in	4.78 mm/0.188 in	3.96 mm/0.156 in
After Finish (limits)	10.3 mm/0.405 in	4.26 mm/0.168 in	4.60 mm/0.181 in

Permeability (μ)	$A_L \pm 8\%$ Kool M μ $A_L \pm 12\%$	Part Number			
		MPP	High Flux	Kool M μ [®]	XFLUX [®]
14	7	55293	58293	-	-
26	14	55292	58292	-	-
60	32	55291	58291	77291	-
75	40	-	-	77295	-
90	48	-	-	77294	-
125	66	55290	58290	77290	-
147	78	55289	58289	-	-
160	84	55288	58288	-	-
173	92	55284	-	-	-
200	105	55287	-	-	-
300	159	55285	-	-	-
550	290	55286	-	-	-

Physical Characteristics	
Window Area	14.3 mm ²
Cross Section	9.45 mm ²
Path Length	21.8 mm
Volume	206 mm ³
Weight- MPP	1.8 g
Weight- High Flux	1.7 g
Weight- Kool M μ	1.4 g
Weight - XFLUX	-
Area Product	135 mm ⁴

Winding Turn Length * Reference General Winding Data pages	
WINDING FACTOR	LENGTH/TURN (mm)
0%	15.2
20%	16.4
25%	16.6
30%	16.9
35%	17.2
40%	17.4
45%	17.8
50%	18.1
60%	18.7
70%	19.5

Wound Coil Dimensions	
Max OD (70%)	13.4 mm
Max HT (70%)	8.20 mm

Surface Area	
Unwound Core	346 mm ²
40% Winding Factor	470 mm ²

Kool M μ A_L vs. DC Bias

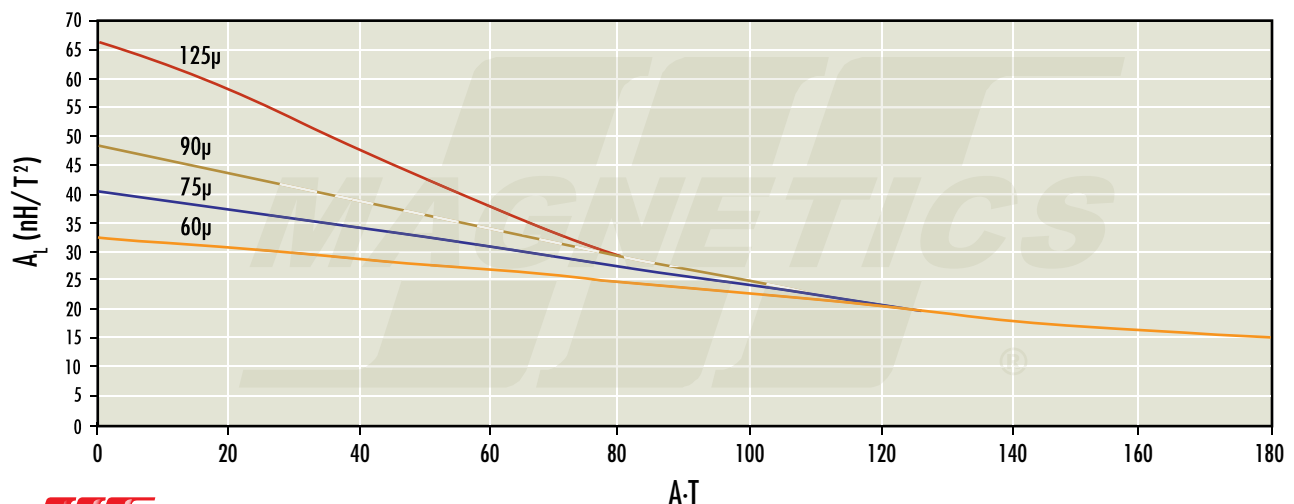

10.2 mm OD

Core Dimensions	OD(max)	ID(min)	HT(max)
Before Finish (nominal)	10.2 mm/0.400 in	5.08 mm/0.200 in	3.96 mm/0.156 in
After Finish (limits)	10.8 mm/0.425 in	4.57 mm/0.180 in	4.60 mm/0.181 in

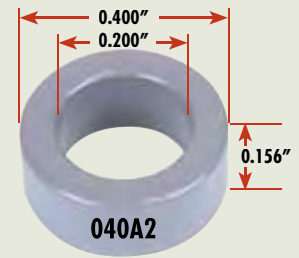

Permeability (μ)	$A_L \pm 8\%$ Kool M μ $A_L \pm 12\%$	Part Number			
		MPP	High Flux	Kool M μ [®]	XFLUX [®]
14	7	55043	58043	-	-
26	14	55042	58042	-	-
60	32	55041	58041	77041	-
75	40	-	-	77845	-
90	48	-	-	77844	-
125	66	55040	58040	77040	-
147	78	55039	58039	-	-
160	84	55038	58038	-	-
173	92	55034	-	-	-
200	105	55037	-	-	-
300	159	55035	-	-	-
550	290	55036	-	-	-

Physical Characteristics	
Window Area	16.4 mm ²
Cross Section	9.57 mm ²
Path Length	23.0 mm
Volume	220 mm ³
Weight- MPP	1.9 g
Weight- High Flux	1.8 g
Weight- Kool M μ	1.5 g
Weight - XFLUX	-
Area Product	156 mm ⁴

Wound Coil Dimensions	
Max OD (70%)	14.1 mm
Max HT (70%)	8.46 mm

Winding Turn Length * Reference General Winding Data pages	
WINDING FACTOR	LENGTH/TURN (mm)
0%	15.4
20%	16.6
25%	16.9
30%	17.1
35%	17.5
40%	17.8
45%	18.1
50%	18.4
60%	19.2
70%	20.0

Surface Area	
Unwound Core	370 mm ²
40% Winding Factor	510 mm ²

Kool M μ A_L vs. DC Bias

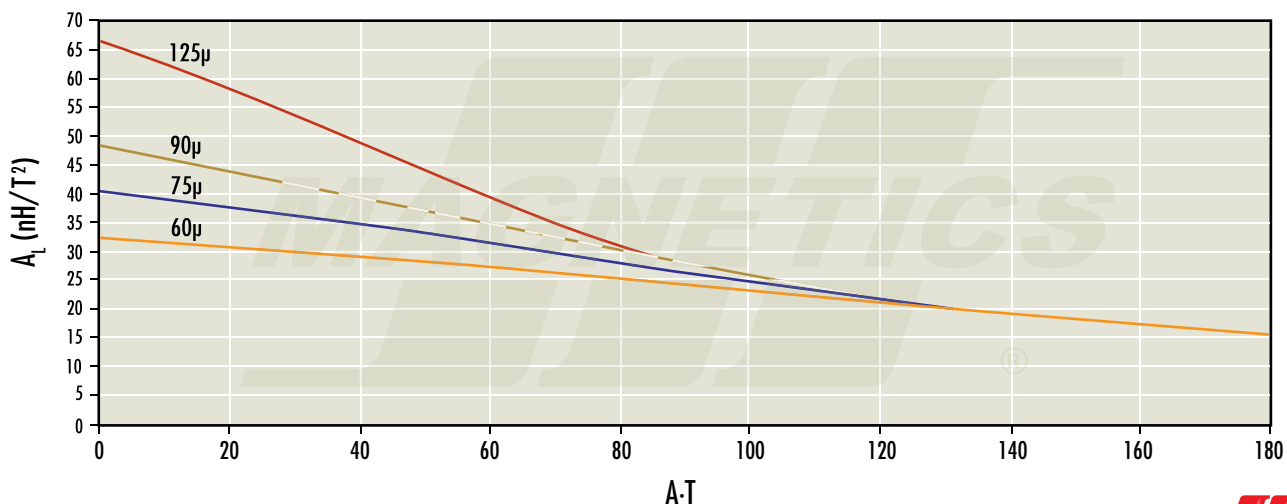

11.2 mm OD

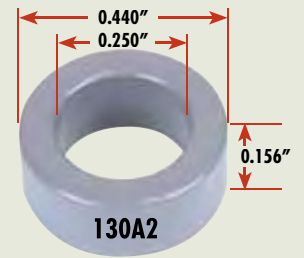

Core Dimensions	OD(max)	ID(min)	HT(max)
Before Finish (nominal)	11.2 mm/0.440 in	6.35 mm/0.250 in	3.96 mm/0.156 in
After Finish (limits)	11.9 mm/0.465 in	5.84 mm/0.230 in	4.60 mm/0.181 in

Permeability (μ)	$A_L \pm 8\%$ Kool M μ $A_L \pm 12\%$	Part Number			
		MPP	High Flux	Kool M μ [®]	XFLUX [®]
14	6	55133	58133	-	-
26	11	55132	58132	-	-
60	26	55131	58131	77131	-
75	32	-	-	77335	-
90	38	-	-	77334	-
125	53	55130	58130	77130	-
147	63	55129	58129	-	-
160	68	55128	58128	-	-
173	74	55124	-	-	-
200	85	55127	-	-	-
300	127	55125	-	-	-

Physical Characteristics	
Window Area	26.8 mm ²
Cross Section	9.06 mm ²
Path Length	26.9 mm
Volume	244 mm ³
Weight- MPP	2.1 g
Weight- High Flux	2.0 g
Weight- Kool M μ	1.5 g
Weight - XFLUX	-
Area Product	243 mm ⁴

Winding Turn Length * Reference General Winding Data pages	
WINDING FACTOR	LENGTH/TURN (mm)
0%	15.2
20%	16.7
25%	17.0
30%	17.4
35%	17.8
40%	18.1
45%	18.6
50%	19.0
60%	19.9
70%	20.9

Wound Coil Dimensions	
Max OD (70%)	15.7 mm
Max HT (70%)	8.97 mm

Surface Area	
Unwound Core	431 mm ²
40% Winding Factor	604 mm ²

Kool M μ A_L vs. DC Bias

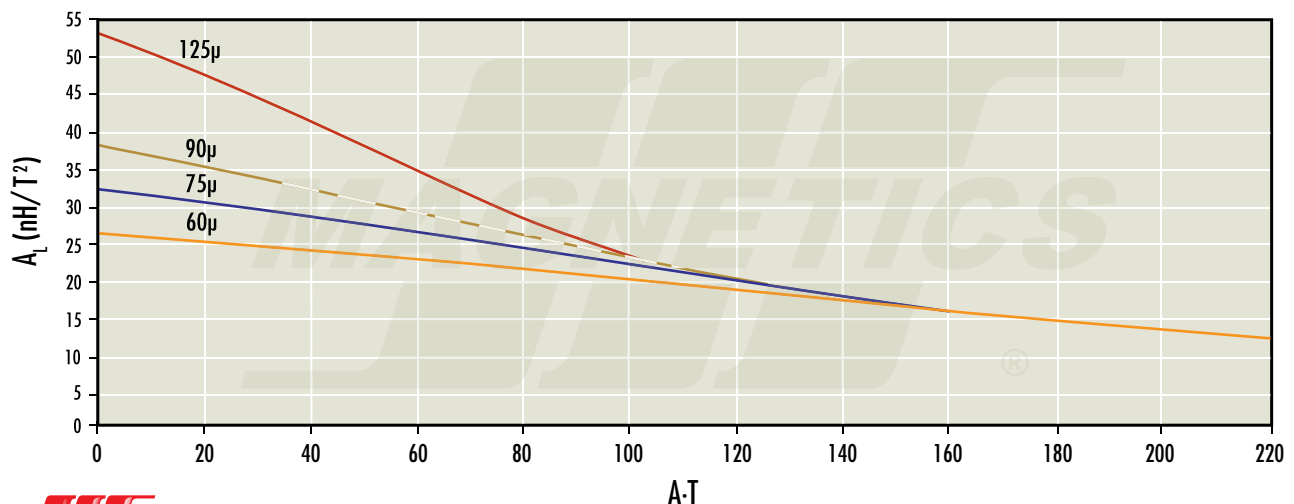

12.7 mm OD

Core Dimensions	OD(max)	ID(min)	HT(max)
Before Finish (nominal)	12.7 mm/0.500 in	7.62 mm/0.300 in	4.75 mm/0.187 in
After Finish (limits)	13.5 mm/0.530 in	6.98 mm/0.275 in	5.52 mm/0.217 in

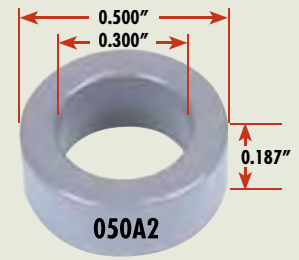

Permeability (μ)	$A_L \pm 8\%$	Part Number			
		MPP	High Flux	Kool M μ [®]	XFLUX [®]
14	6.4	55053	58053	-	-
26	12	55052	58052	-	-
60	27	55051	58051	77051	78051
75	34	-	-	77055	-
90	40	-	-	77054	-
125	56	55050	58050	77050	-
147	67	55049	58049	-	-
160	72	55048	58048	-	-
173	79	55044	-	-	-
200	90	55047	-	-	-
300	134	55045	-	-	-
550	255	55046	-	-	-

Physical Characteristics	
Window Area	38.3 mm ²
Cross Section	10.9 mm ²
Path Length	31.2 mm
Volume	340 mm ³
Weight- MPP	3.1 g
Weight- High Flux	2.9 g
Weight- Kool M μ	2.2 g
Weight - XFLUX	2.5 g
Area Product	417 mm ⁴

Wound Coil Dimensions	
Max OD (70%)	18.2 mm
Max HT (70%)	11.5 mm

Winding Turn Length * Reference General Winding Data pages	
WINDING FACTOR	LENGTH/TURN (mm)
0%	17.5
20%	19.3
25%	19.8
30%	20.1
35%	20.7
40%	21.1
45%	21.7
50%	22.1
60%	23.2
70%	24.5

Surface Area	
Unwound Core	561 mm ²
40% Winding Factor	813 mm ²

Kool M μ A_L vs. DC Bias

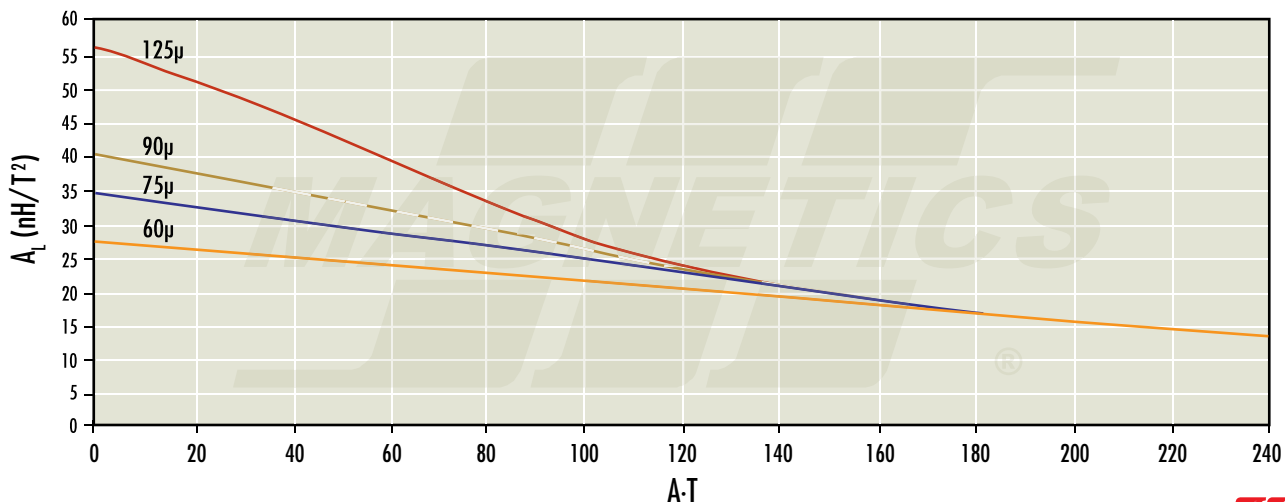

16.6 mm OD

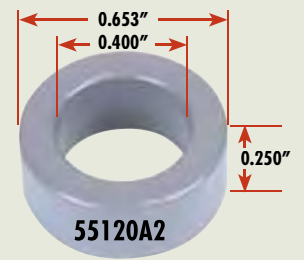

Core Dimensions	OD(max)	ID(min)	HT(max)
Before Finish (nominal)	16.6 mm/0.653 in	10.2 mm/0.400 in	6.35 mm/0.250 in
After Finish (limits)	17.3 mm/0.680 in	9.52 mm/0.375 in	7.12 mm/0.280 in

Permeability (μ)	$A_L \pm 8\%$	Part Number			
		MPP	High Flux	Kool M μ [®]	XFLUX [®]
14	8	55123	58123	-	-
26	15	55122	58122	-	-
60	35	55121	58121	77121	78121
75	43	-	-	77225	-
90	52	-	-	77224	-
125	72	55120	58120	77120	-
147	88	55119	58119	-	-
160	92	55118	58118	-	-
173	104	55114	-	-	-
200	115	55117	-	-	-
300	173	55115	-	-	-
550	317	55116	-	-	-

Physical Characteristics	
Window Area	71.2 mm ²
Cross Section	19.2 mm ²
Path Length	41.2 mm
Volume	791 mm ³
Weight- MPP	6.8 g
Weight- High Flux	6.3 g
Weight- Kool M μ	5.0 g
Weight - XFLUX	5.6 g
Area Product	1,370 mm ⁴

Winding Turn Length * Reference General Winding Data pages	
WINDING FACTOR	LENGTH/TURN (mm)
0%	22.1
20%	24.6
25%	25.2
30%	25.6
35%	26.4
40%	27.0
45%	27.7
50%	28.4
60%	29.8
70%	31.5

Wound Coil Dimensions	
Max OD (70%)	23.7 mm
Max HT (70%)	15.2 mm

Surface Area	
Unwound Core	922 mm ²
40% Winding Factor	1,360 mm ²

Kool M μ A_L vs. DC Bias

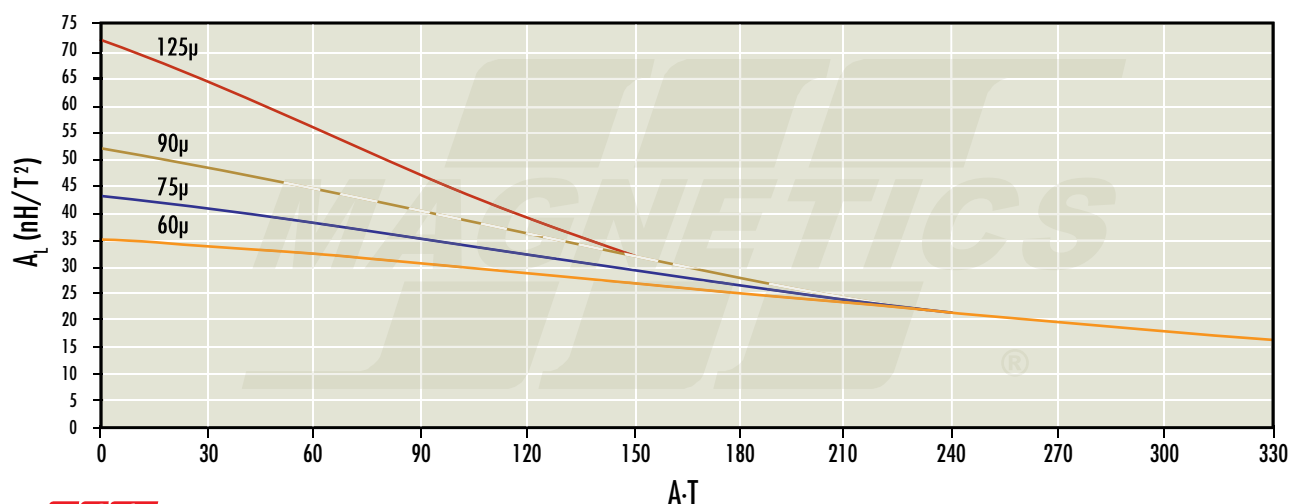

17.3 mm OD

Core Dimensions	OD(max)	ID(min)	HT(max)
Before Finish (nominal)	17.3 mm/0.680 in	9.65 mm/0.380 in	6.35 mm/0.250 in
After Finish (limits)	18.1 mm/0.710 in	9.01 mm/0.355 in	7.12 mm/0.280 in

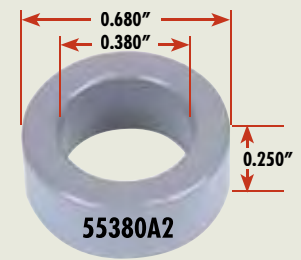

Permeability (μ)	$A_L \pm 8\%$	Part Number			
		MPP	High Flux	Kool M μ [®]	XFLUX [®]
14	10	55383	58383	-	-
26	19	55382	58382	-	-
60	43	55381	58381	77381	78381
75	53	-	-	77385	-
90	64	-	-	77384	-
125	89	55380	58380	77380	-
147	105	55379	58379	-	-
160	114	55378	58378	-	-
173	123	55374	-	-	-
200	142	55377	-	-	-
300	214	55375	-	-	-

Physical Characteristics	
Window Area	63.8 mm ²
Cross Section	23.2 mm ²
Path Length	41.4 mm
Volume	960 mm ³
Weight- MPP	8.2 g
Weight- High Flux	7.7 g
Weight- Kool M μ	5.9 g
Weight - XFLUX	7.2 g
Area Product	1,480 mm ⁴

Wound Coil Dimensions	
Max OD (70%)	24.9 mm
Max HT (70%)	16.3 mm

Winding Turn Length * Reference General Winding Data pages	
WINDING FACTOR	LENGTH/TURN (mm)
0%	23.2
20%	25.6
25%	26.2
30%	26.6
35%	27.4
40%	28.0
45%	28.6
50%	29.3
60%	30.8
70%	32.4

Surface Area	
Unwound Core	987 mm ²
40% Winding Factor	1,470 mm ²

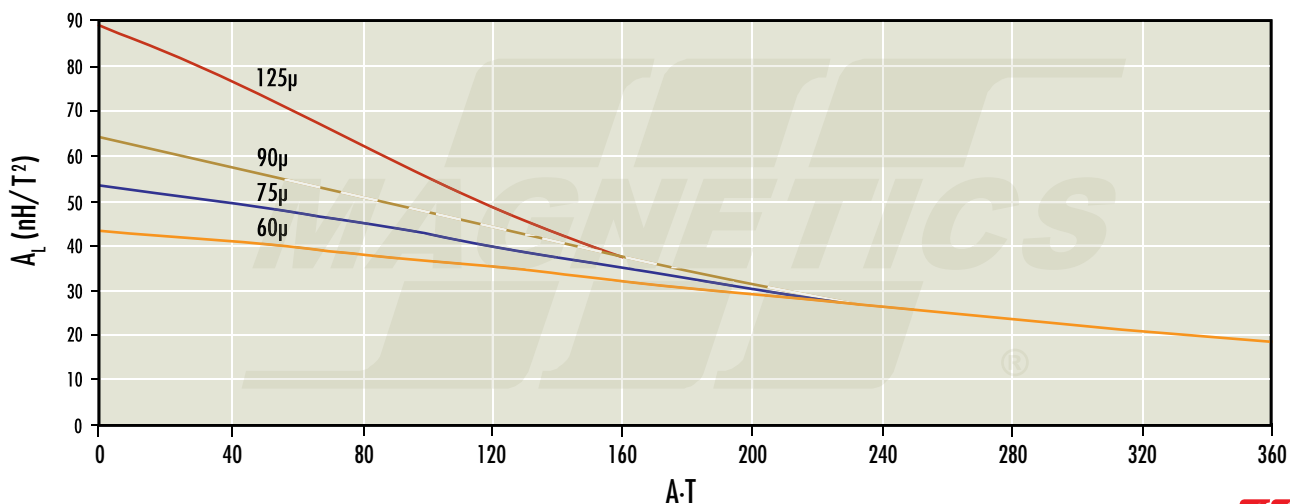
Kool M μ A_L vs. DC Bias

20.3 mm OD

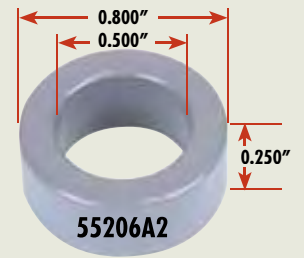

Core Dimensions	OD(max)	ID(min)	HT(max)
Before Finish (nominal)	20.3 mm/0.800 in	12.7 mm/0.500 in	6.35mm/0.250 in
After Finish (limits)	21.1 mm/0.830 in	12.0 mm/0.475 in	7.12 mm/0.280 in

Permeability (μ)	$A_L \pm 8\%$	Part Number			
		MPP	High Flux	Kool M μ [®]	XFLUX [®]
14	7.8	55209	58209	-	-
26	14	55208	58208	-	-
40	21	-	-	77847	-
60	32	55848	58848	77848	78848
75	41	-	-	77211	-
90	49	-	-	77210	-
125	68	55206	58206	77206	-
147	81	55205	58205	-	-
160	87	55204	58204	-	-
173	96	55200	-	-	-
200	109	55203	-	-	-
300	163	55201	-	-	-
550	320	55202	-	-	-

Physical Characteristics	
Window Area	114 mm ²
Cross Section	22.1 mm ²
Path Length	50.9 mm
Volume	1,120 mm ³
Weight- MPP	9.4 g
Weight- High Flux	8.9 g
Weight- Kool M μ	7.1 g
Weight - XFLUX	7.9 g
Area Product	2,520 mm ⁴

Winding Turn Length * Reference General Winding Data pages	
WINDING FACTOR	LENGTH/TURN (mm)
0%	23.3
20%	26.4
25%	27.2
30%	27.8
35%	28.8
40%	29.5
45%	30.5
50%	31.3
60%	33.2
70%	35.4

Wound Coil Dimensions	
Max OD (70%)	29.2 mm
Max HT (70%)	16.5 mm

Surface Area	
Unwound Core	1,210 mm ²
40% Winding Factor	1,890 mm ²

Kool M μ A_L vs. DC Bias

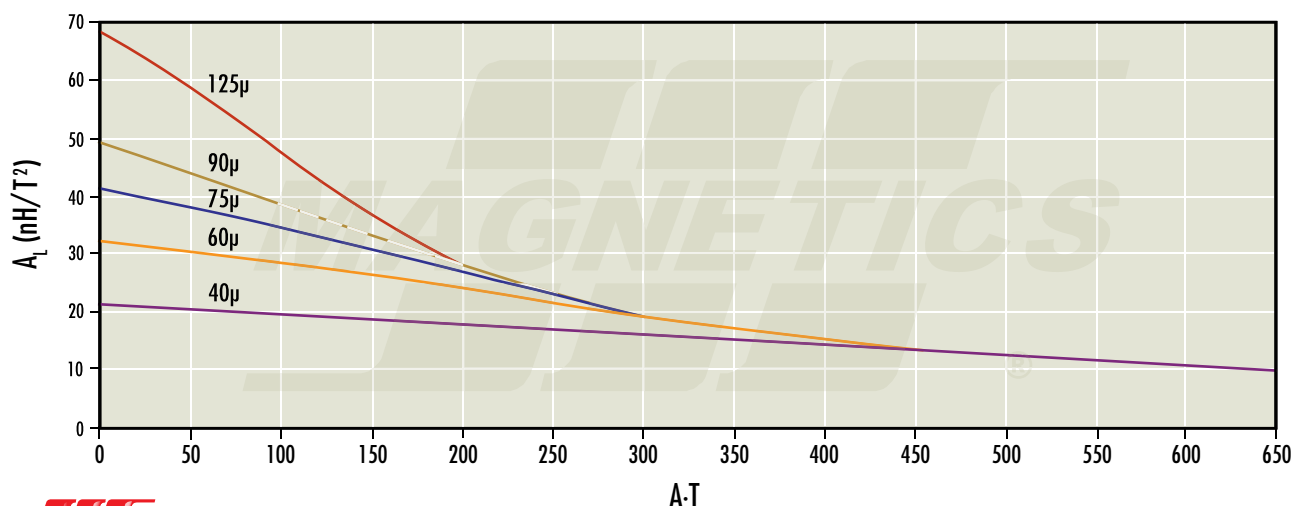

22.9 mm OD

Core Dimensions	OD(max)	ID(min)	HT(max)
Before Finish (nominal)	22.9 mm/0.900 in	14.0 mm/0.550 in	7.62 mm/0.300 in
After Finish (limits)	23.7 mm/0.930 in	13.3 mm/0.525 in	8.39 mm/0.330 in

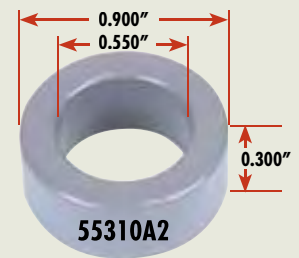

Permeability (μ)	$A_L \pm 8\%$	Part Number			
		MPP	High Flux	Kool M μ [®]	XFLUX [®]
14	9.9	55313	58313	-	-
26	19	55312	58312	77312	-
40	29	-	-	77316	-
60	43	55059	58059	77059	78059
75	54	-	-	77315	-
90	65	-	-	77314	-
125	90	55310	58310	77310	-
147	106	55309	58309	-	-
160	115	55308	58308	-	-
173	124	55304	-	-	-
200	144	55307	-	-	-
300	216	55305	-	-	-
550	396	55306	-	-	-

Physical Characteristics	
Window Area	139 mm ²
Cross Section	31.7 mm ²
Path Length	56.7 mm
Volume	1,800 mm ³
Weight- MPP	16 g
Weight- High Flux	15 g
Weight- Kool M μ	12 g
Weight - XFLUX	13 g
Area Product	4,430 mm ⁴

Wound Coil Dimensions	
Max OD (70%)	32.6 mm
Max HT (70%)	19.8 mm

Winding Turn Length * Reference General Winding Data pages	
WINDING FACTOR	LENGTH/TURN (mm)
0%	27.0
20%	30.5
25%	31.3
30%	32.0
35%	33.1
40%	33.9
45%	34.9
50%	35.9
60%	38.0
70%	40.4

Surface Area	
Unwound Core	1,570 mm ²
40% Winding Factor	2,380 mm ²

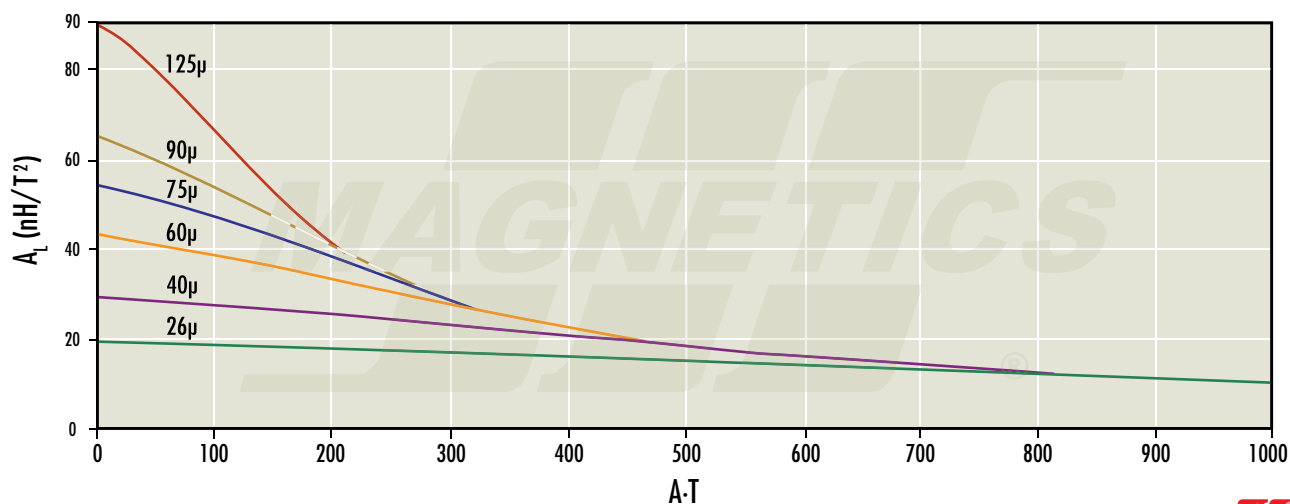
Kool M μ A_L vs. DC Bias

23.6 mm OD

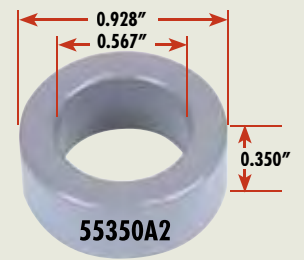

Core Dimensions	OD(max)	ID(min)	HT(max)
Before Finish (nominal)	23.6 mm/0.928 in	14.4 mm/0.567 in	8.89 mm/0.350 in
After Finish (limits)	24.4 mm/0.958 in	13.7 mm/0.542 in	9.66 mm/0.380 in

Permeability (μ)	$A_L \pm 8\%$	Part Number			
		MPP	High Flux	Kool M μ [®]	XFLUX [®]
14	12	55353	58353	-	-
26	22	55352	58352	77352	-
40	34	-	-	77356	-
60	51	55351	58351	77351	78351
75	62	-	-	77355	-
90	76	-	-	77354	-
125	105	55350	58350	77350	-
147	124	55349	58349	-	-
160	135	55348	58348	-	-
173	146	55344	-	-	-
200	169	55347	-	-	-
300	253	55345	-	-	-

Physical Characteristics	
Window Area	149 mm ²
Cross Section	38.8 mm ²
Path Length	58.8 mm
Volume	2,280 mm ³
Weight- MPP	20 g
Weight- High Flux	19 g
Weight- Kool M μ	14 g
Weight - XFLUX	16 g
Area Product	5,770 mm ⁴

Winding Turn Length * Reference General Winding Data pages	
WINDING FACTOR	LENGTH/TURN (mm)
0%	29.8
20%	33.4
25%	34.2
30%	35.0
35%	36.1
40%	36.9
45%	38.0
50%	38.9
60%	41.1
70%	43.6

Wound Coil Dimensions	
Max OD (70%)	33.5 mm
Max HT (70%)	21.4 mm

Surface Area	
Unwound Core	1,790 mm ²
40% Winding Factor	2,630 mm ²

Kool M μ A_L vs. DC Bias

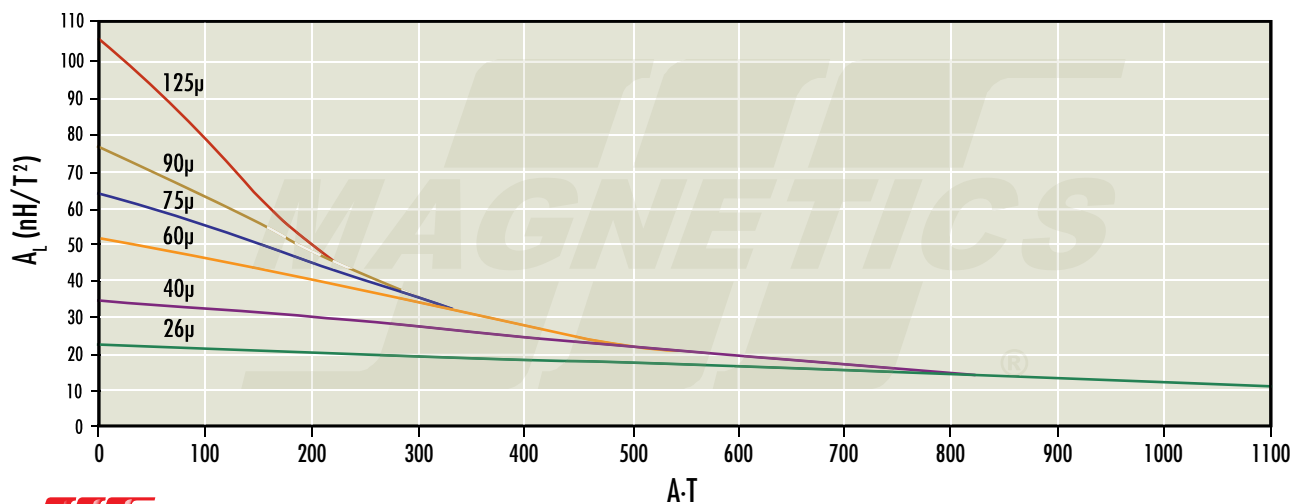

26.9 mm OD

Core Dimensions	OD(max)	ID(min)	HT(max)
Before Finish (nominal)	26.90 mm/1.060 in	14.7 mm/0.580 in	11.2 mm/0.440 in
After Finish (limits)	27.69 mm/1.090 in	14.1 mm/0.555 in	12.0 mm/0.470 in

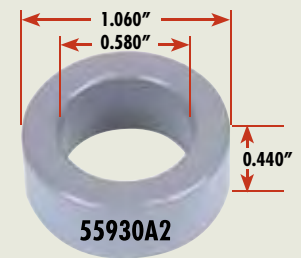

Permeability (μ)	$A_L \pm 8\%$	Part Number			
		MPP	High Flux	Kool M μ [®]	XFLUX [®]
14	18	55933	58933	-	-
26	32	55932	58932	77932	-
40	50	-	-	77936	-
60	75	55894	58894	77894	78894
75	94	-	-	77935	-
90	113	-	-	77934	-
125	157	55930	58930	77930	-
147	185	55929	58929	-	-
160	201	55928	58928	-	-
173	217	55924	-	-	-
200	251	55927	-	-	-
300	377	55925	-	-	-
550	740	55926	-	-	-

Physical Characteristics	
Window Area	156 mm ²
Cross Section	65.4 mm ²
Path Length	63.5 mm
Volume	4,150 mm ³
Weight- MPP	36 g
Weight- High Flux	34 g
Weight- Kool M μ	26 g
Weight - XFLUX	29 g
Area Product	10,200 mm ⁴

Wound Coil Dimensions	
Max OD (70%)	37.3 mm
Max HT (70%)	24.0 mm

Winding Turn Length * Reference General Winding Data pages	
WINDING FACTOR	LENGTH/TURN (mm)
0%	37.5
20%	41.1
25%	41.9
30%	42.8
35%	43.8
40%	44.6
45%	45.7
50%	46.6
60%	48.8
70%	51.3

Surface Area	
Unwound Core	2,470 mm ²
40% Winding Factor	3,380 mm ²

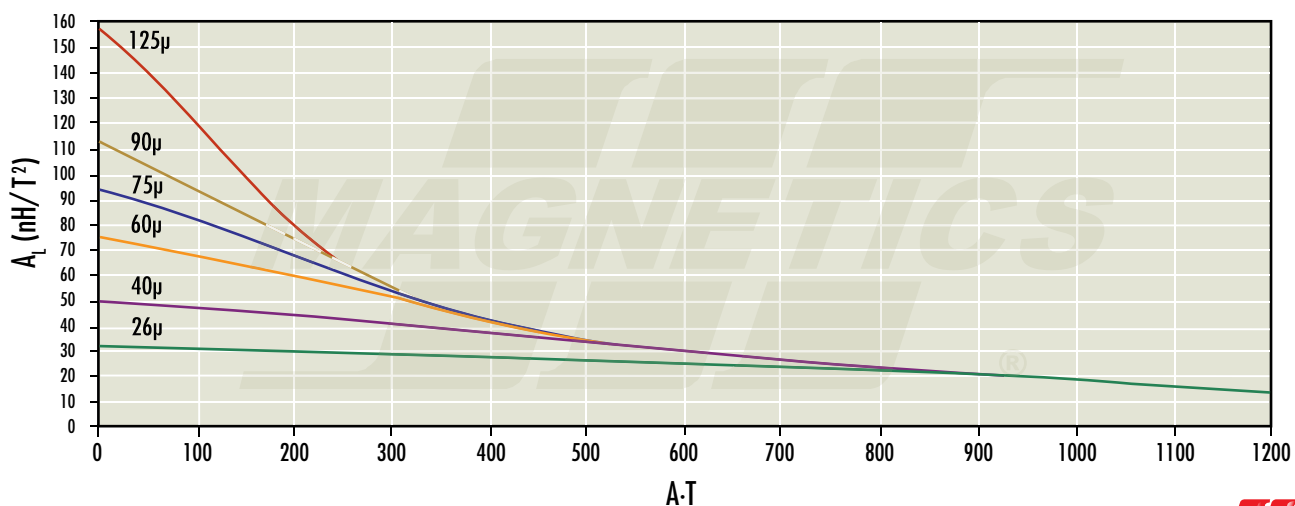
Kool M μ A_L vs. DC Bias

32.8 mm OD

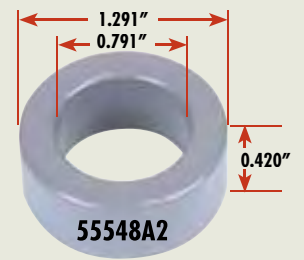

Core Dimensions	OD(max)	ID(min)	HT(max)
Before Finish (nominal)	32.8 mm/1.291 in	20.1 mm/0.791 in	10.7 mm/0.420 in
After Finish (limits)	33.66 mm/1.325 in	19.4 mm/0.766 in	11.5 mm/0.450 in

Permeability (μ)	$A_L \pm 8\%$	Part Number			
		MPP	High Flux	Kool M μ [®]	XFLUX [®]
14	14	55551	58551	-	-
26	28	55550	58550	77550	-
40	41	-	-	77555	-
60	61	55071	58071	77071	78071
75	76	-	-	77553	-
90	91	-	-	77552	-
125	127	55548	58548	77548	-
147	150	55547	58547	-	-
160	163	55546	58546	-	-
173	176	55542	-	-	-
200	203	55545	-	-	-
300	305	55543	-	-	-
550	559	55544	-	-	-

Physical Characteristics	
Window Area	297 mm ²
Cross Section	65.6 mm ²
Path Length	81.4 mm
Volume	5,340 mm ³
Weight- MPP	47 g
Weight- High Flux	44 g
Weight- Kool M μ	34 g
Weight - XFLUX	38 g
Area Product	19,500 mm ⁴

Winding Turn Length * Reference General Winding Data pages	
WINDING FACTOR	LENGTH/TURN (mm)
0%	37.4
20%	42.4
25%	43.5
30%	44.7
35%	46.1
40%	47.2
45%	48.8
50%	50.1
60%	53.2
70%	56.7

Wound Coil Dimensions	
Max OD (70%)	46.7 mm
Max HT (70%)	28.0 mm

Surface Area	
Unwound Core	3,150 mm ²
40% Winding Factor	4,800 mm ²

Kool M μ A_L vs. DC Bias

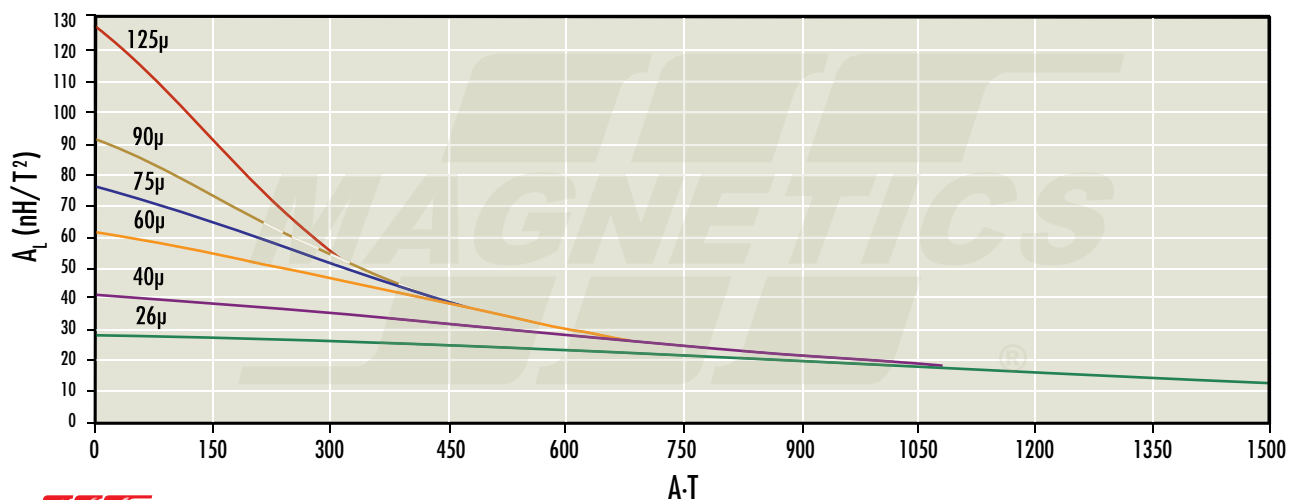

34.3 mm OD

Core Dimensions	OD(max)	ID(min)	HT(max)
Before Finish (nominal)	34.30 mm/1.350 in	23.4 mm/0.920 in	8.89 mm/0.350 in
After Finish (limits)	35.18 mm/1.385 in	22.5 mm/0.888 in	9.78 mm/0.385 in

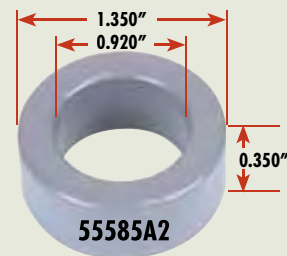

Permeability (μ)	$A_L \pm 8\%$	Part Number			
		MPP	High Flux	Kool M μ [®]	XFLUX [®]
14	9	55588	58588	-	-
26	16	55587	58587	77587	-
40	25	-	-	77591	-
60	38	55586	58586	77586	78586
75	47	-	-	77590	-
90	57	-	-	77589	-
125	79	55585	58585	77585	-
147	93	55584	58584	-	-
160	101	55583	58583	-	-
173	109	55579	-	-	-
200	126	55582	-	-	-
300	190	55580	-	-	-
550	348	55581	-	-	-

Physical Characteristics	
Window Area	399 mm ²
Cross Section	46.4 mm ²
Path Length	89.5 mm
Volume	4,150 mm ³
Weight- MPP	35 g
Weight- High Flux	33 g
Weight- Kool M μ	25 g
Weight - XFLUX	29 g
Area Product	18,500 mm ⁴

Wound Coil Dimensions	
Max OD (70%)	50.1 mm
Max HT (70%)	29.0 mm

Winding Turn Length <small>* Reference General Winding Data pages</small>	
WINDING FACTOR	LENGTH/TURN (mm)
0%	32.2
20%	38.1
25%	39.6
30%	40.6
35%	42.5
40%	44.0
45%	45.6
50%	47.3
60%	50.8
70%	54.9

Surface Area	
Unwound Core	2,930 mm ²
40% Winding Factor	5,130 mm ²

Kool M μ A_L vs. DC Bias

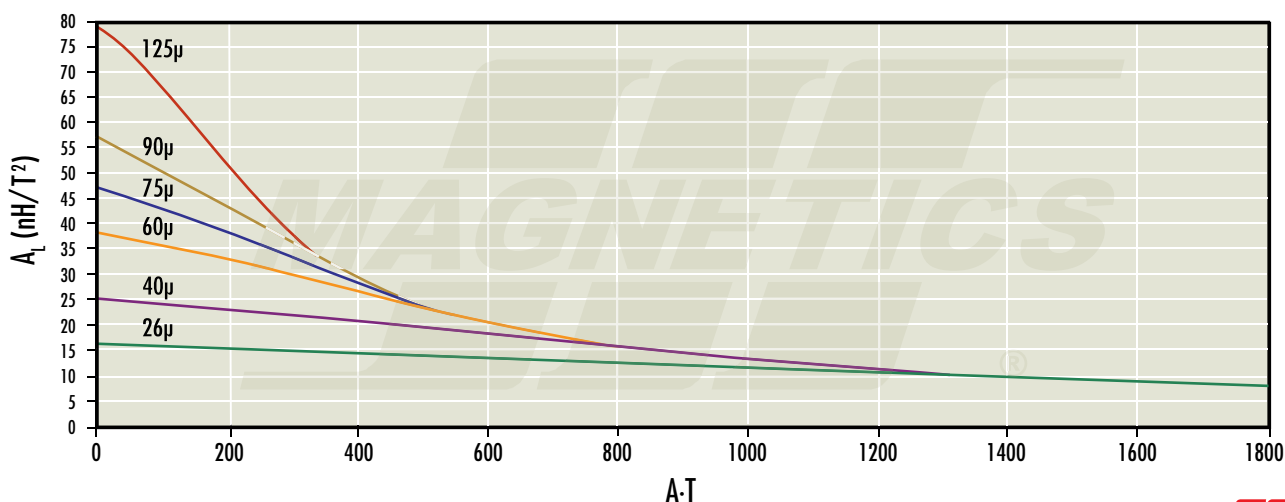

35.8 mm OD

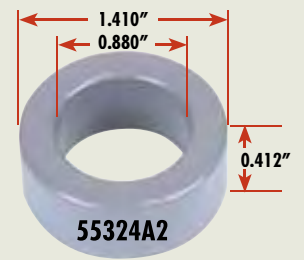

Core Dimensions	OD(max)	ID(min)	HT(max)
Before Finish (nominal)	35.80 mm/1.410 in	22.4 mm/0.880 in	10.5 mm/0.412 in
After Finish (limits)	36.71 mm/1.445 in	21.5 mm/0.848 in	11.4 mm/0.447 in

Permeability (μ)	$A_L \pm 8\%$	Part Number			
		MPP	High Flux	Kool M μ [®]	XFLUX [®]
14	13	55327	58327	-	-
26	24	55326	58326	77326	-
40	37	-	-	77330	-
60	56	55076	58076	77076	78076
75	70	-	-	77329	-
90	84	-	-	77328	-
125	117	55324	58324	77324	-
147	138	55323	58323	-	-
160	150	55322	58322	-	-
173	162	55318	-	-	-
200	187	55321	-	-	-
300	281	55319	-	-	-
550	515	55320	-	-	-

Physical Characteristics	
Window Area	364 mm ²
Cross Section	67.8 mm ²
Path Length	89.8 mm
Volume	6,090 mm ³
Weight- MPP	52 g
Weight- High Flux	49 g
Weight- Kool M μ	37 g
Weight - XFLUX	43 g
Area Product	24,700 mm ⁴

Winding Turn Length * Reference General Winding Data pages	
WINDING FACTOR	LENGTH/TURN (mm)
0%	37.9
20%	43.5
25%	44.8
30%	46.0
35%	47.6
40%	48.9
45%	50.6
50%	52.0
60%	55.5
70%	59.3

Wound Coil Dimensions	
Max OD (70%)	51.1 mm
Max HT (70%)	29.6 mm

Surface Area	
Unwound Core	3,450 mm ²
40% Winding Factor	5,510 mm ²

Kool M μ A_L vs. DC Bias

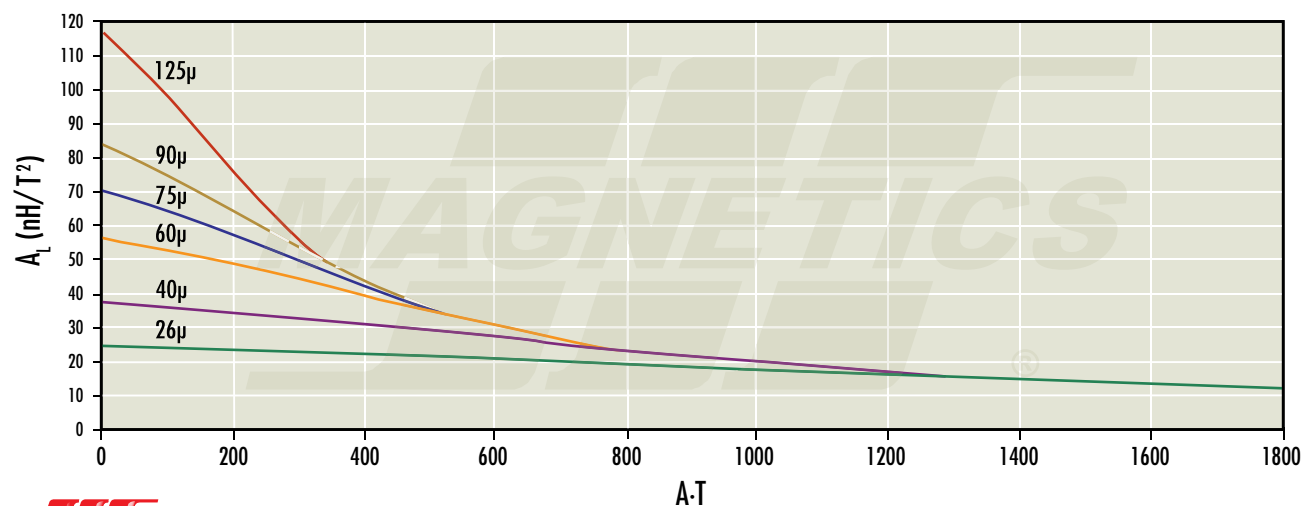

39.9 mm OD

Core Dimensions	OD(max)	ID(min)	HT(max)
Before Finish (nominal)	39.90 mm/1.570 in	24.1 mm/0.950 in	14.5 mm/0.570 in
After Finish (limits)	40.77 mm/1.605 in	23.3 mm/0.918 in	15.4 mm/0.605 in

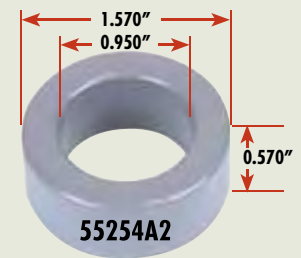

Permeability (μ)	$A_L \pm 8\%$	Part Number			
		MPP	High Flux	Kool M μ [®]	XFLUX [®]
14	19	55257	58257	-	-
26	35	55256	58256	77256	-
40	54	-	-	77260	-
60	81	55083	58083	77083	78083
75	101	-	-	77259	-
90	121	-	-	77258	-
125	168	55254	58254	77254	-
147	198	55253	58253	-	-
160	215	55252	58252	-	-
173	233	55248	-	-	-
200	269	55251	-	-	-
300	403	55249	-	-	-
550	740	55250	-	-	-

Physical Characteristics	
Window Area	427 mm ²
Cross Section	107 mm ²
Path Length	98.4 mm
Volume	10,600 mm ³
Weight- MPP	92 g
Weight- High Flux	87 g
Weight- Kool M μ	65 g
Weight - XFLUX	78 g
Area Product	45,800 mm ⁴

Wound Coil Dimensions	
Max OD (70%)	56.4 mm
Max HT (70%)	35.2 mm

Winding Turn Length * Reference General Winding Data pages	
WINDING FACTOR	LENGTH/TURN (mm)
0%	48.2
20%	54.3
25%	55.8
30%	57.0
35%	58.8
40%	60.2
45%	62.1
50%	63.7
60%	67.3
70%	71.5

Surface Area	
Unwound Core	4,840 mm ²
40% Winding Factor	7,160 mm ²

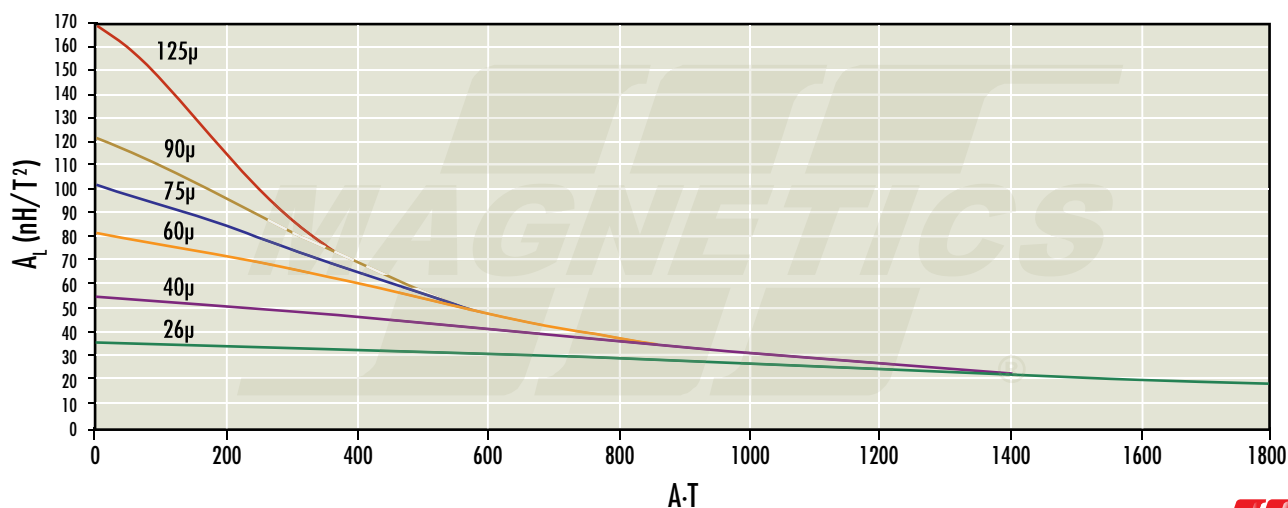
Kool M μ A_L vs. DC Bias

46.7 mm OD

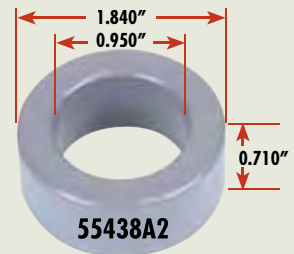

Core Dimensions	OD(max)	ID(min)	HT(max)
Before Finish (nominal)	46.70 mm/1.840 in	24.1 mm/0.950 in	18.0 mm/0.710 in
After Finish (limits)	47.63 mm/1.875 in	23.3 mm/0.918 in	19.0 mm/0.745 in

Permeability (μ)	$A_L \pm 8\%$	Part Number			
		MPP	High Flux	Kool M μ [®]	XFLUX [®]
14	32	55441	58441	-	-
26	59	55440	58440	77440	-
40	90	-	-	77431	-
60	135	55439	58439	77439	78439
75	169	-	-	77443	-
90	202	-	-	77442	-
125	281	55438	58438	77438	-
147	330	55437	58437	-	-
160	360	55436	-	-	-
173	390	55432	-	-	-
200	450	55435	-	-	-
300	674	55433	-	-	-

Physical Characteristics	
Window Area	427 mm ²
Cross Section	199 mm ²
Path Length	107 mm
Volume	21,300 mm ³
Weight- MPP	180 g
Weight- High Flux	170 g
Weight- Kool M μ	130 g
Weight - XFLUX	150 g
Area Product	85,900 mm ⁴

Winding Turn Length * Reference General Winding Data pages	
WINDING FACTOR	LENGTH/TURN (mm)
0%	62.1
20%	68.2
25%	69.7
30%	70.9
35%	72.7
40%	74.1
45%	76.0
50%	77.6
60%	81.2
70%	85.4

Wound Coil Dimensions	
Max OD (70%)	63.8 mm
Max HT (70%)	38.7 mm

Surface Area	
Unwound Core	6,900 mm ²
40% Winding Factor	9,420 mm ²

Kool M μ A_L vs. DC Bias

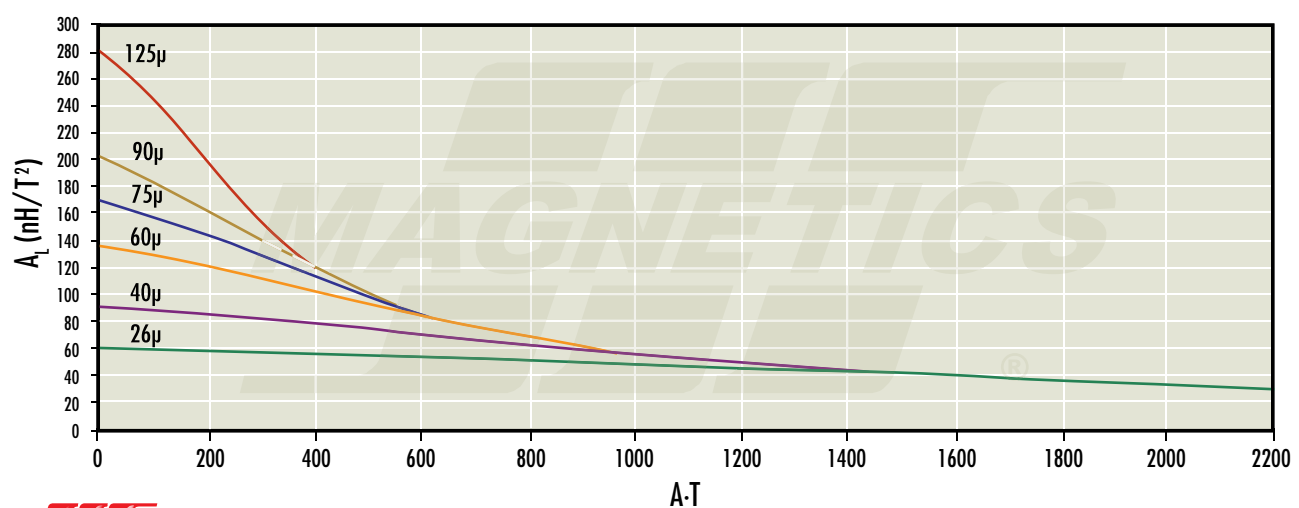

46.7 mm OD

Core Dimensions	OD(max)	ID(min)	HT(max)
Before Finish (nominal)	46.70 mm/1.840 in	28.70 mm/1.130 in	15.2 mm/0.600 in
After Finish (limits)	47.63 mm/1.875 in	27.88 mm/1.098 in	16.2 mm/0.635 in

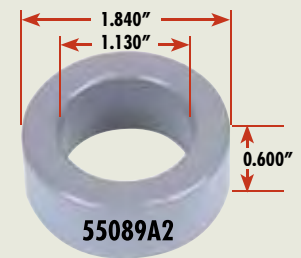

Permeability (μ)	$A_L \pm 8\%$	Part Number			
		MPP	High Flux	Kool M μ [®]	XFLUX [®]
14	20	55092	58092	-	-
26	37	55091	58091	77091	-
40	57	-	-	77095	-
60	86	55090	58090	77090	78090
75	107	-	-	77094	-
90	128	-	-	77093	-
125	178	55089	58089	77089	-
147	210	55088	-	-	-
160	228	55087	-	-	-
173	246	55082	-	-	-
200	285	55086	-	-	-
300	427	55084	-	-	-

Physical Characteristics	
Window Area	610 mm ²
Cross Section	134 mm ²
Path Length	116 mm
Volume	15,600 mm ³
Weight- MPP	130 g
Weight- High Flux	120 g
Weight- Kool M μ	96 g
Weight - XFLUX	110 g
Area Product	81,800 mm ⁴

Wound Coil Dimensions	
Max OD (70%)	66.3 mm
Max HT (70%)	39.8 mm

Winding Turn Length * Reference General Winding Data pages	
WINDING FACTOR	LENGTH/TURN (mm)
0%	52.0
20%	59.1
25%	61.0
30%	62.2
35%	64.5
40%	66.4
45%	68.2
50%	70.4
60%	74.7
70%	79.5

Surface Area	
Unwound Core	6,170 mm ²
40% Winding Factor	9,510 mm ²

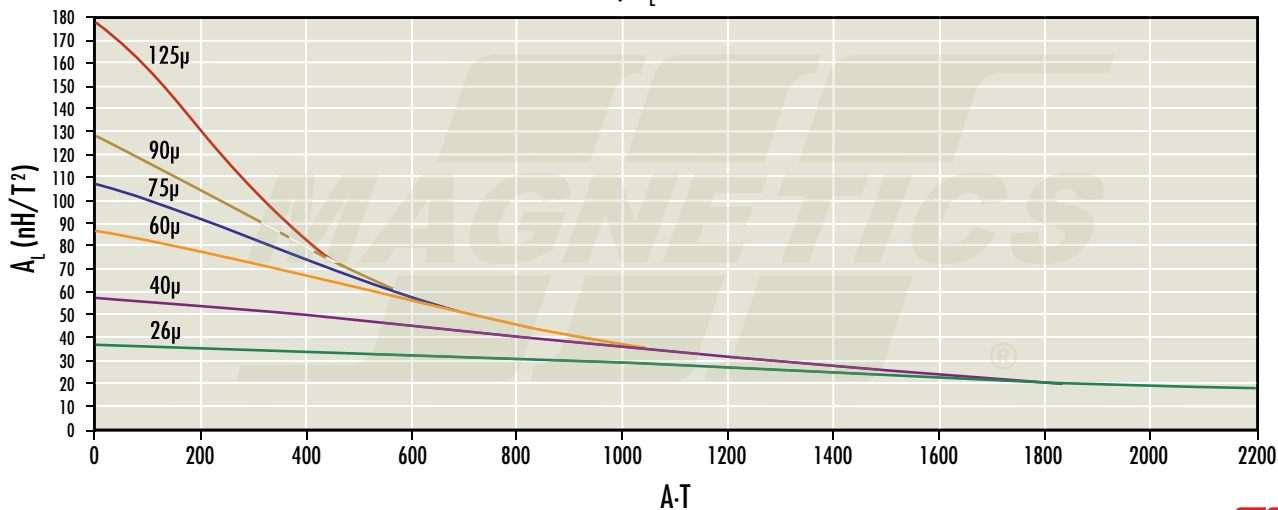
Kool M μ A_L vs. DC Bias

50.8 mm OD

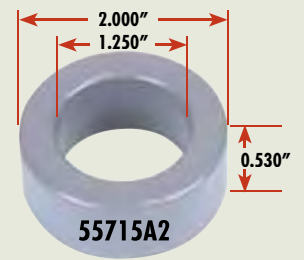

Core Data

Core Dimensions	OD(max)	ID(min)	HT(max)
Before Finish (nominal)	50.80 mm/2.000 in	31.80 mm/1.250 in	13.5 mm/0.530 in
After Finish (limits)	51.69 mm/2.035 in	30.93 mm/1.218 in	14.4 mm/0.565 in

Permeability (μ)	$A_L \pm 8\%$	Part Number			
		MPP	High Flux	Kool M μ [®]	XFLUX [®]
14	17	55718	58718	-	-
26	32	55717	58717	77717	-
40	49	-	-	77721	-
60	73	55716	58716	77716	78716
75	91	-	-	77720	-
90	109	-	-	77719	-
125	152	55715	58715	77715	-
147	179	55714	58714	-	-
160	195	55713	-	-	-
173	210	55709	-	-	-
200	243	55712	-	-	-
300	365	55710	-	-	-

Physical Characteristics	
Window Area	751 mm ²
Cross Section	125 mm ²
Path Length	127 mm
Volume	15,900 mm ³
Weight- MPP	140 g
Weight- High Flux	130 g
Weight- Kool M μ	98 g
Weight - XFLUX	110 g
Area Product	94,000 mm ⁴

Winding Turn Length * Reference General Winding Data pages	
WINDING FACTOR	LENGTH/TURN (mm)
0%	49.5
20%	57.4
25%	59.6
30%	61.0
35%	63.5
40%	65.5
45%	67.7
50%	70.1
60%	74.9
70%	80.3

Wound Coil Dimensions	
Max OD (70%)	72.4 mm
Max HT (70%)	40.6 mm

Surface Area	
Unwound Core	6,420 mm ²
40% Winding Factor	10,600 mm ²

Kool M μ A_L vs. DC Bias

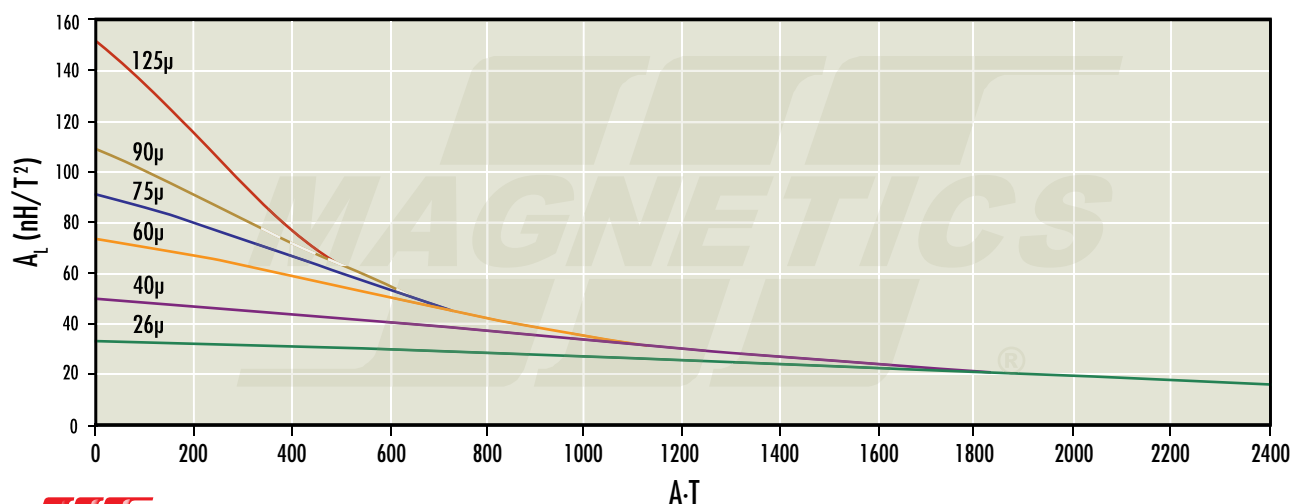

57.2 mm OD

Core Dimensions	OD(max)	ID(min)	HT(max)
Before Finish (nominal)	57.20 mm/2.250 in	26.40 mm/1.039 in	15.2 mm/0.600 in
After Finish (limits)	58.04 mm/2.285 in	25.57 mm/1.007 in	16.2 mm/0.635 in

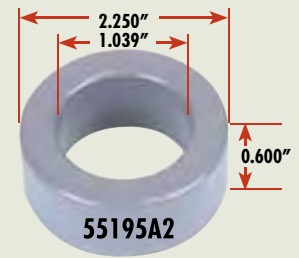

Permeability (μ)	$A_L \pm 8\%$	Part Number			
		MPP	High Flux	Kool M μ [®]	XFLUX [®]
14	32	55190	58190	-	-
26	60	55191	58191	77191	-
40	92	-	-	77189	-
60	138	55192	58192	77192	78192
75	172	-	-	77193	-
90	207	-	-	77194	-
125	287	55195	58195	77195	-
147	306	55196	-	-	-
160	333	55197	-	-	-
173	360	55198	-	-	-
200	417	55199	-	-	-

Physical Characteristics	
Window Area	514 mm ²
Cross Section	229 mm ²
Path Length	125 mm
Volume	28,600 mm ³
Weight- MPP	240 g
Weight- High Flux	230 g
Weight- Kool M μ	180 g
Weight - XFLUX	200 g
Area Product	118,000 mm ⁴

Wound Coil Dimensions	
Max OD (70%)	75.7 mm
Max HT (70%)	34.0 mm

Winding Turn Length * Reference General Winding Data pages	
WINDING FACTOR	LENGTH/TURN (mm)
0%	64.6
20%	71.2
25%	72.9
30%	74.1
35%	76.3
40%	77.8
45%	79.8
50%	81.6
60%	85.6
70%	90.1

Surface Area	
Unwound Core	9,100 mm ²
40% Winding Factor	11,500 mm ⁴

Kool M μ A_L vs. DC Bias

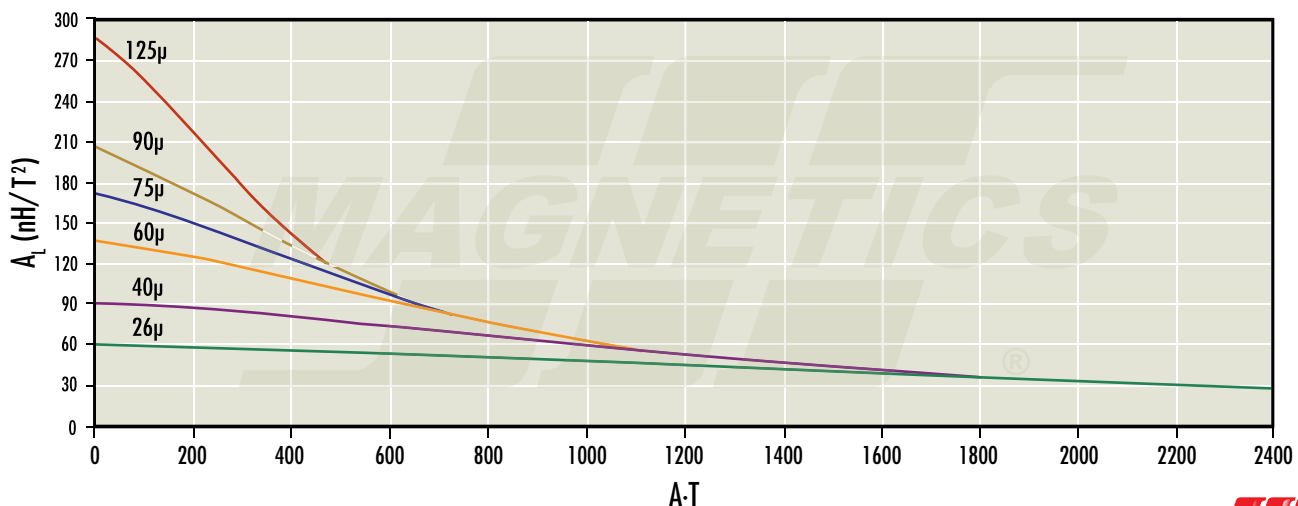

57.2 mm OD

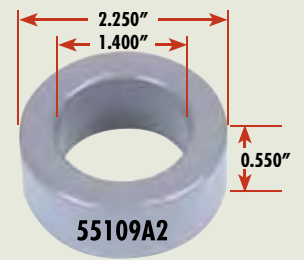

Core Dimensions	OD(max)	ID(min)	HT(max)
Before Finish (nominal)	57.20 mm/2.250 in	35.60 mm/1.400 in	14.0 mm/0.550 in
After Finish (limits)	58.04 mm/2.285 in	34.74 mm/1.368 in	14.9 mm/0.585 in

Permeability (μ)	$A_L \pm 8\%$	Part Number			
		MPP	High Flux	Kool M μ [®]	XFLUX [®]
14	18	55112	58112	-	-
26	33	55111	58111	77111	-
40	50	-	-	77212	-
60	75	55110	58110	77110	78110
75	94	-	-	77214	-
90	112	-	-	77213	-
125	156	55109	58109	77109	-
147	185	55108	-	-	-
160	200	55107	-	-	-
173	218	55103	-	-	-
200	250	55106	-	-	-
300	374	55104	-	-	-

Physical Characteristics	
Window Area	948 mm ²
Cross Section	144 mm ²
Path Length	143 mm
Volume	20,700 mm ³
Weight- MPP	180 g
Weight- High Flux	170 g
Weight- Kool M μ	130 g
Weight - XFLUX	150 g
Area Product	137,000 mm ⁴

Winding Turn Length * Reference General Winding Data pages	
WINDING FACTOR	LENGTH/TURN (mm)
0%	53.0
20%	61.9
25%	64.3
30%	65.8
35%	68.7
40%	71.0
45%	73.2
50%	76.0
60%	81.3
70%	87.1

Wound Coil Dimensions	
Max OD (70%)	81.3 mm
Max HT (70%)	44.4 mm

Surface Area	
Unwound Core	7,680 mm ²
40% Winding Factor	13,100 mm ²

Kool M μ A_L vs. DC Bias

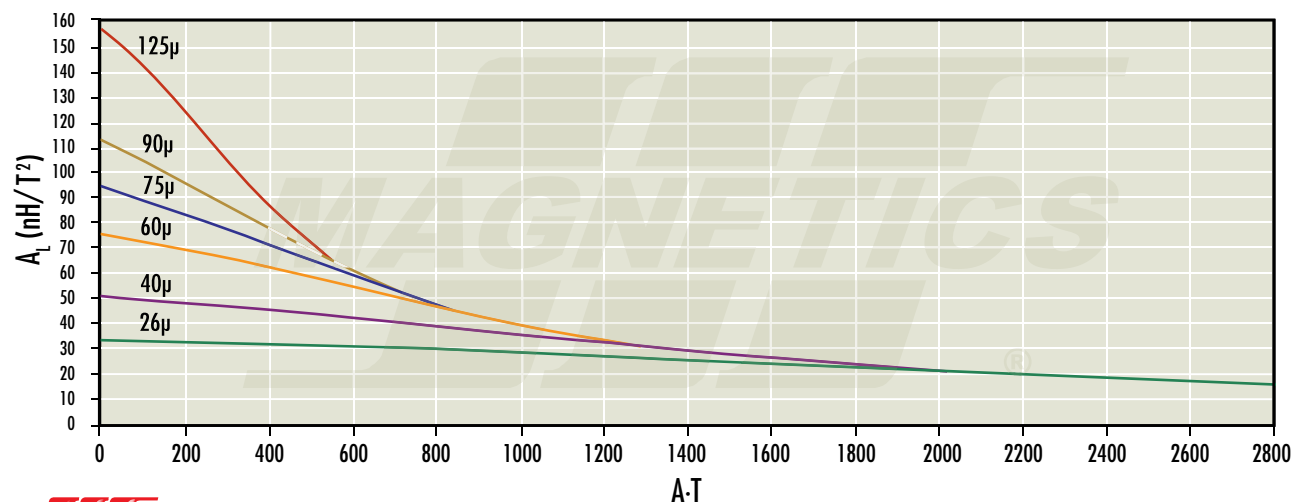

62.0 mm OD

Core Dimensions	OD(max)	ID(min)	HT(max)
Before Finish (nominal)	62.00 mm/2.440 in	32.60 mm/1.283 in	25.0 mm/0.984 in
After Finish (limits)	62.91 mm/2.477 in	31.69 mm/1.248 in	25.91 mm/1.020 in

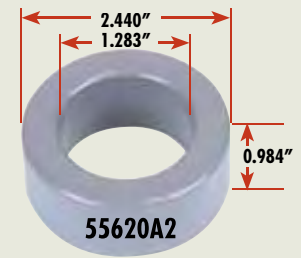

Permeability (μ)	$A_L \pm 8\%$	Part Number			
		MPP	High Flux	Kool M μ [®]	XFLUX [®]
14	44	55614	58614	-	-
26	82	55615	58615	77615	-
40	126	-	-	77616	-
60	189	55617	58617	77617	-
75	237	-	-	77618	-
90	284	-	-	77619	-
125	394	55620	58620	-	-

Physical Characteristics	
Window Area	789 mm ²
Cross Section	360 mm ²
Path Length	144 mm
Volume	51,800 mm ³
Weight- MPP	460 g
Weight- High Flux	440 g
Weight- Kool M μ	340 g
Weight - XFLux	-
Area Product	284,000 mm ⁴

Surface Area	
Max OD (70%)	81.4 mm
Max HT (70%)	47.4 mm

Winding Turn Length <small>* Reference General Winding Data pages</small>	
WINDING FACTOR	LENGTH/TURN (mm)
0%	83.0
20%	91.3
25%	93.4
30%	94.9
35%	97.5
40%	99.5
45%	102
50%	104
60%	109
70%	115

Wound Coil Dimensions	
Unwound Core	12,300 mm ²
40% Winding Factor	16,800 mm ²

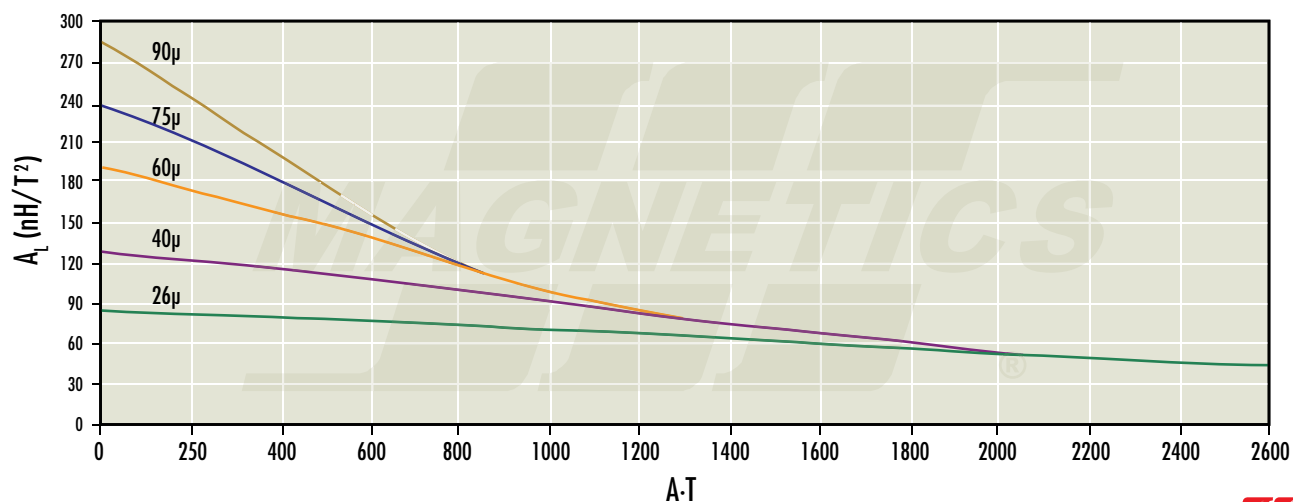
Kool M μ A_L vs. DC Bias

74.1 mm OD

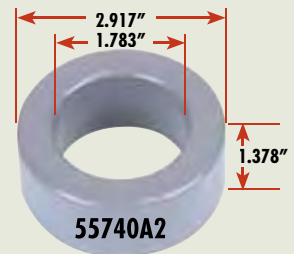

Core Dimensions	OD(max)	ID(min)	HT(max)
Before Finish (nominal)	74.10 mm/2.917 in	45.30 mm/1.783 in	35.00 mm/1.378 in
After Finish (limits)	75.01 mm/2.953 in	44.39 mm/1.748 in	35.92 mm/1.414 in

Permeability (μ)	$A_L \pm 8\%$	Part Number			
		MPP	High Flux	Kool M μ [®]	XFLUX [®]
14	48	55734	58734	-	-
26	88	55735	58735	77735	-
40	136	-	-	77736	-
60	204	55737	58737	77737	-
75	255	-	-	77738	-
90	306	-	-	77739	-
125	425	55740	58740	-	-

Physical Characteristics	
Window Area	1,550 mm ²
Cross Section	497 mm ²
Path Length	184 mm
Volume	91,400 mm ³
Weight- MPP	790 g
Weight- High Flux	750 g
Weight- Kool M μ	570 g
Weight - XFLUX	-
Area Product	769,000 mm ⁴

Winding Turn Length * Reference General Winding Data pages	
WINDING FACTOR	LENGTH/TURN (mm)
0%	102
20%	114
25%	117
30%	119
35%	122
40%	125
45%	129
50%	132
60%	139
70%	147

Surface Area	
Max OD (70%)	102 mm
Max HT (70%)	65.7 mm

Wound Coil Dimensions	
Unwound Core	18,800 mm ²
40% Winding Factor	27,100 mm ²

Kool M μ A_L vs. DC Bias

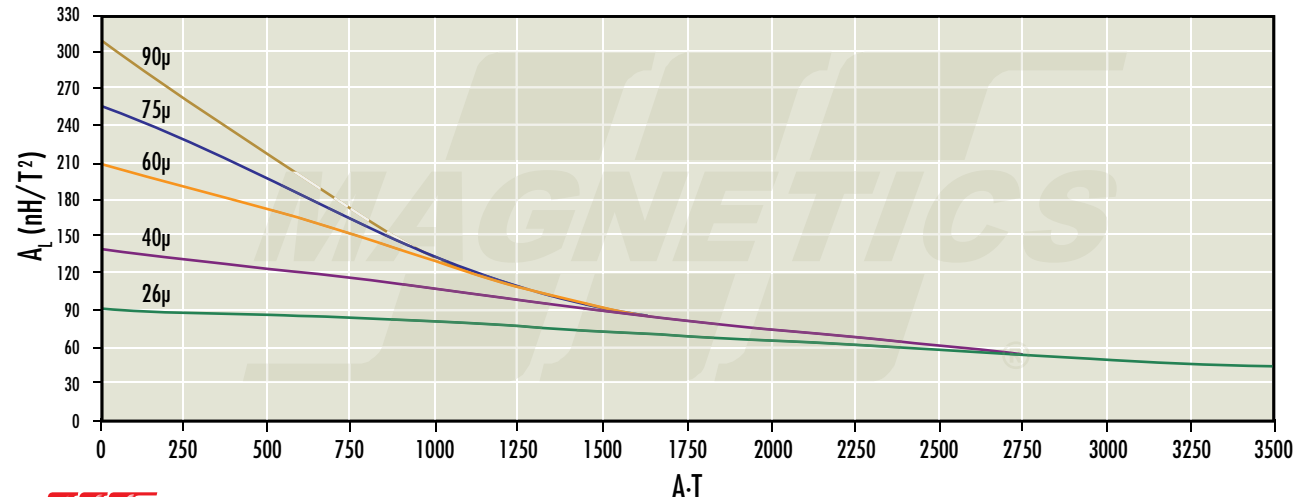

77.8 mm OD

Core Dimensions	OD(max)	ID(min)	HT(max)
Before Finish (nominal)	77.80 mm/3.063 in	49.20 mm/1.938 in	12.7 mm/0.500 in
After Finish (limits)	78.95 mm/3.108 in	48.20 mm/1.898 in	13.9 mm/0.545 in

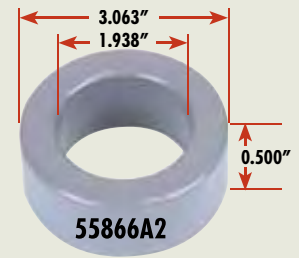

Permeability (μ)	$A_L \pm 8\%$	Part Number			
		MPP	High Flux	Kool M μ [®]	XFLUX [®]
14	16	55869	58869	-	-
26	30	55868	58868	77868	-
40	45	-	-	77872	-
60	68	55867	58867	77867	78867
125	142	55866	58866	-	-

Physical Characteristics	
Window Area	1,820 mm ²
Cross Section	176 mm ²
Path Length	196 mm
Volume	34,500 mm ³
Weight- MPP	290 g
Weight- High Flux	270 g
Weight- Kool M μ	210 g
Weight - XFLUX	240 g
Area Product	321,000 mm ⁴

Wound Coil Dimensions	
Max OD (70%)	112 mm
Max HT (70%)	54.3 mm

Winding Turn Length <small>* Reference General Winding Data pages</small>	
WINDING FACTOR	LENGTH/TURN (mm)
0%	58.4
20%	70.9
25%	74.1
30%	76.3
35%	80.4
40%	83.5
45%	86.7
50%	90.4
60%	98.1
70%	107

Surface Area	
Unwound Core	11,700 mm ²
40% Winding Factor	20,300 mm ²

Kool M μ A_L vs. DC Bias

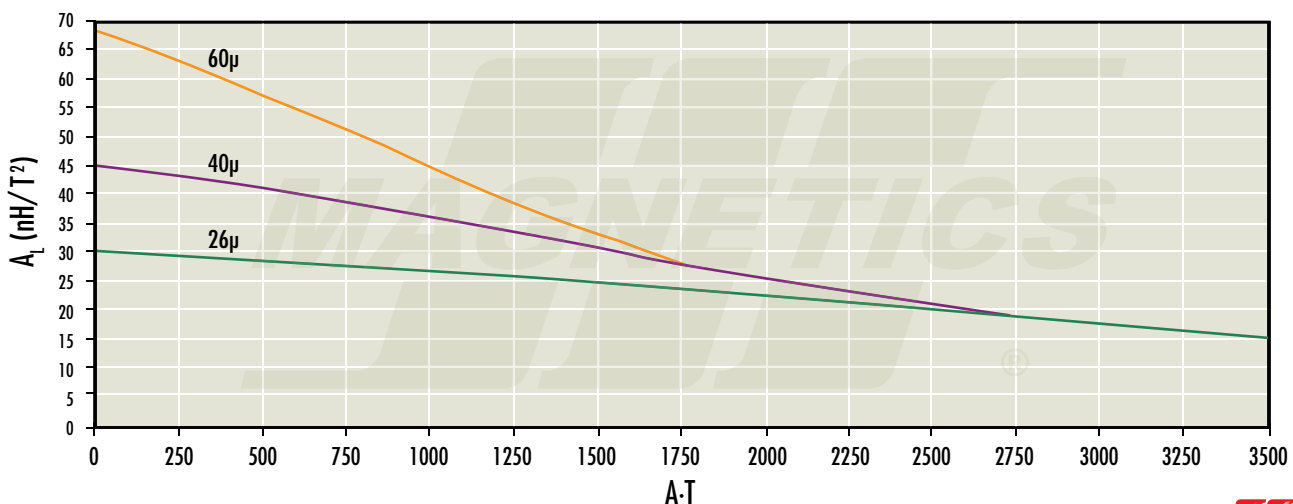

77.8 mm OD

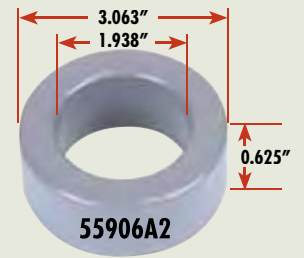

Core Data

Core Dimensions	OD(max)	ID(min)	HT(max)
Before Finish (nominal)	77.80 mm/3.063 in	49.20 mm/1.938 in	15.9 mm/0.625 in
After Finish (limits)	78.95 mm/3.108 in	48.20 mm/1.898 in	17.1 mm/0.670 in

Permeability (μ)	$A_L \pm 8\%$	Part Number			
		MPP	High Flux	Kool M μ [®]	XFLUX [®]
14	20	55909	58909	-	-
26	37	55908	58908	77908	-
40	57	-	-	77912	-
60	85	55907	58907	77907	78907
125	177	55906	58906	77906	-

Physical Characteristics	
Window Area	1,820 mm ²
Cross Section	221 mm ²
Path Length	196 mm
Volume	43,400 mm ³
Weight- MPP	380 g
Weight- High Flux	360 g
Weight- Kool M μ	280 g
Weight - XFLUX	320 g
Area Product	403,000 mm ⁴

Winding Turn Length * Reference General Winding Data pages	
WINDING FACTOR	LENGTH/TURN (mm)
0%	64.7
20%	77.2
25%	80.5
30%	82.7
35%	86.8
40%	89.9
45%	93.1
50%	96.8
60%	104
70%	113

Wound Coil Dimensions	
Max OD (70%)	113 mm
Max HT (70%)	57.7 mm

Surface Area	
Unwound Core	13,000 mm ²
40% Winding Factor	22,500 mm ²

Kool M μ A_L vs. DC Bias

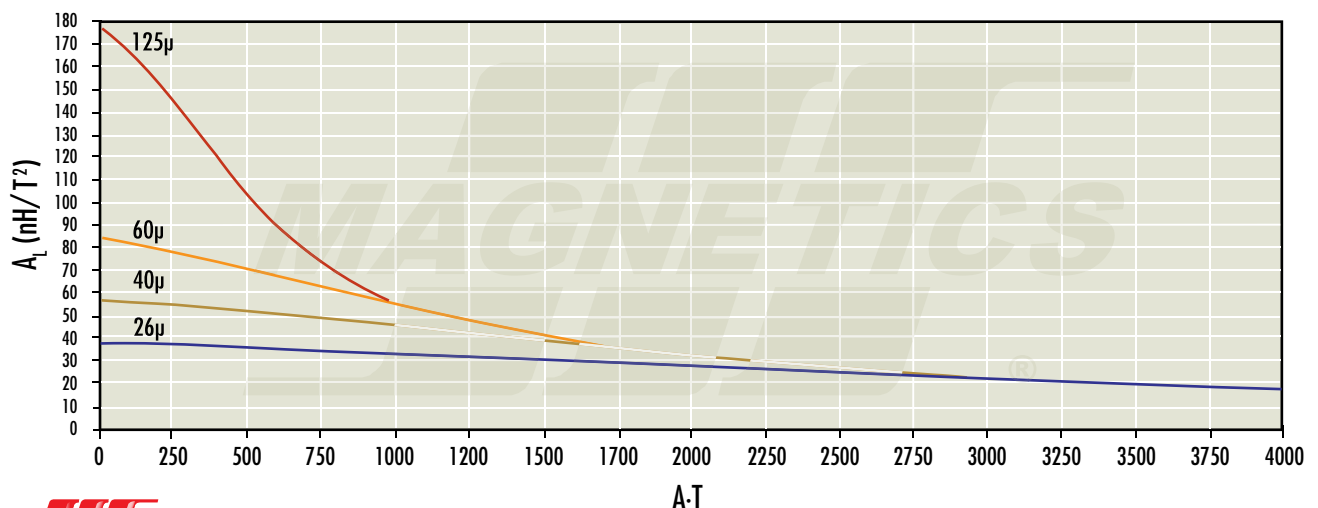

101.6 mm OD

Core Dimensions	OD(max)	ID(min)	HT(max)
Before Finish (nominal)	101.6 mm/4.000 in	57.20 mm/2.252 in	16.5 mm/0.650 in
After Finish (limits)	103.0 mm/4.055 in	55.75 mm/2.195 in	17.9 mm/0.705 in

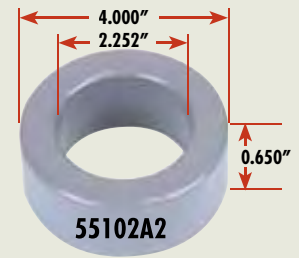

Permeability (μ)	$A_L \pm 8\%$	Part Number			
		MPP	High Flux	Kool M μ [®]	XFLUX [®]
14	26	55101	58101	-	-
26	48	55102	58102	77102	-
40	74	-	-	77100	-
60	111	55099	58099	77099	-
125	232	55098	58098	77098	-

Physical Characteristics	
Window Area	2,470 mm ²
Cross Section	358 mm ²
Path Length	243 mm
Volume	86,900 mm ³
Weight- MPP*	650 g
Weight- High Flux*	610 g
Weight- Kool M μ * [*]	470 g
Weight - XFLUX	-
Area Product	885,000 mm ⁴

Wound Coil Dimensions	
Max OD (70%)	136 mm
Max HT (70%)	55.1 mm

*26 μ , see page 3-2

Winding Turn Length [*] Reference General Winding Data pages	
WINDING FACTOR	LENGTH/TURN (mm)
0%	82.2
20%	96.8
25%	100
30%	103
35%	108
40%	111
45%	116
50%	120
60%	128
70%	139

Surface Area	
Unwound Core	20,700 mm ²
40% Winding Factor	34,600 mm ²

Kool M μ A_L vs. DC Bias

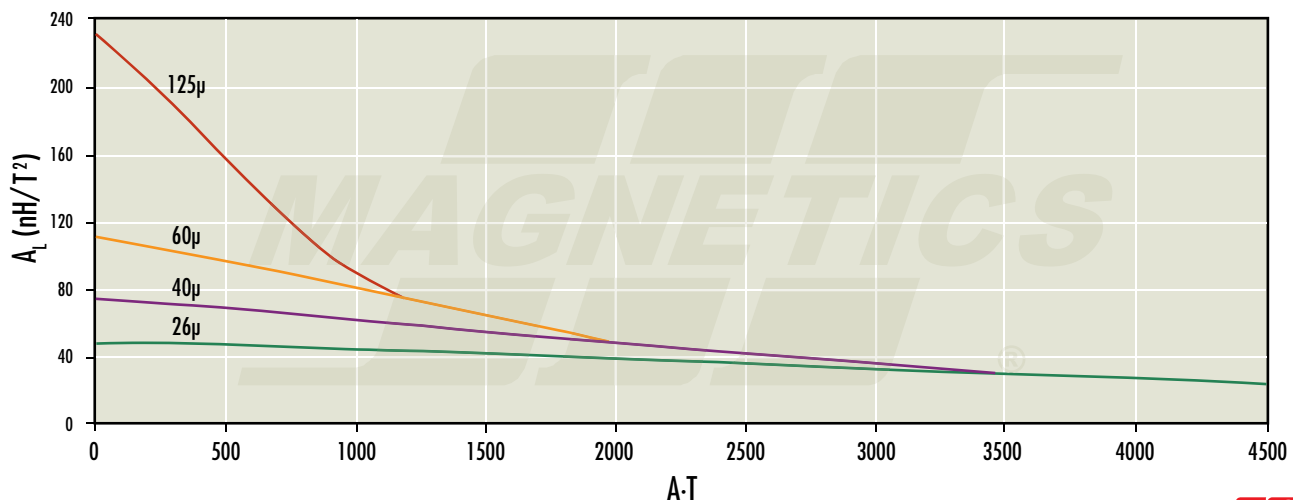

132.6 mm OD

Core Dimensions	OD(max)	ID(min)	HT(max)
Before Finish (nominal)	132.6 mm/5.219 in	78.60 mm/3.094 in	25.4 mm/1.000 in
After Finish (limits)	134.0 mm/5.274 in	77.19 mm/3.039 in	26.8 mm/1.055 in

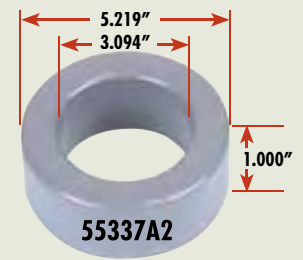

Core Data

Permeability (μ)	$A_L \pm 8\%$	Part Number			
		MPP	High Flux	Kool M μ [®]	XFLUX [®]
14	37	55336	58336	-	-
26	68	55337	58337	77337	-
40	105	-	-	77338	-
60	158	55339	58339	77339	-
125	329	55340	58340	-	-

Physical Characteristics	
Window Area	4,710 mm ²
Cross Section	678 mm ²
Path Length	324 mm
Volume	220,000 mm ³
Weight- MPP*	1,700 g
Weight- High Flux*	1,500 g
Weight- Kool M μ * [*]	1,200 g
Weight - XFLUX	-
Area Product	3,190,000 mm ⁴

Wound Coil Dimensions	
Max OD (70%)	179 mm
Max HT (70%)	78.8 mm

*26 μ , see page 3-2

Winding Turn Length * Reference General Winding Data pages	
WINDING FACTOR	LENGTH/TURN (mm)
0%	110
20%	130
25%	135
30%	139
35%	145
40%	150
45%	156
50%	162
60%	173
70%	187

Surface Area	
Unwound Core	36,600 mm ²
40% Winding Factor	62,000 mm ²

Kool M μ A_L vs. DC Bias

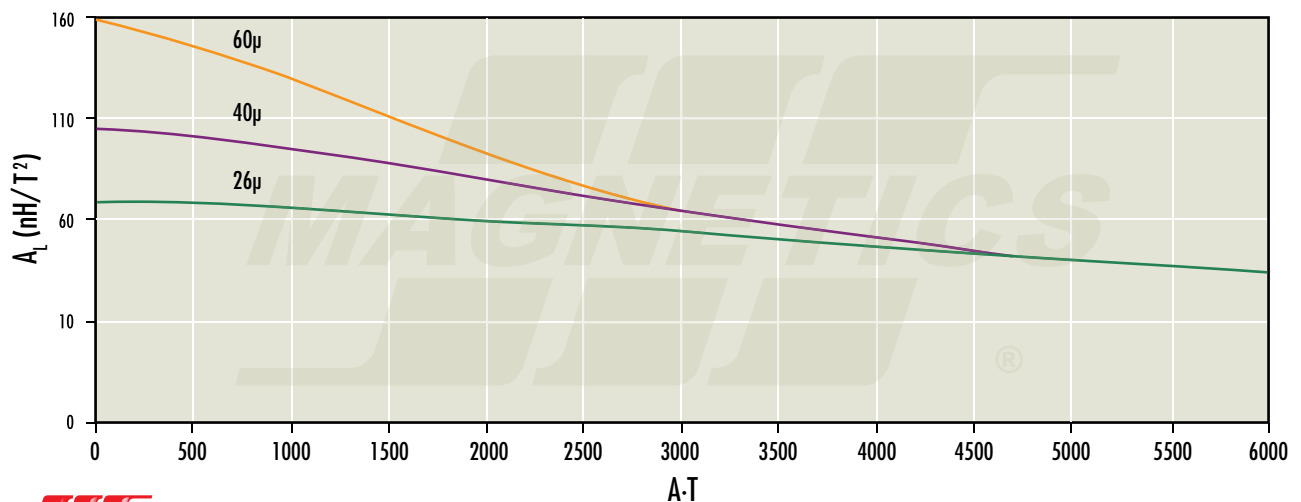

165.1 mm OD

Core Dimensions	OD(max)	ID(min)	HT(max)
Before Finish (nominal)	165.1 mm/6.500 in	102.4 mm/4.032 in	31.75 mm/1.250 in
After Finish (limits)	166.5 mm/6.555 in	101.0 mm/3.977 in	33.15 mm/1.305 in

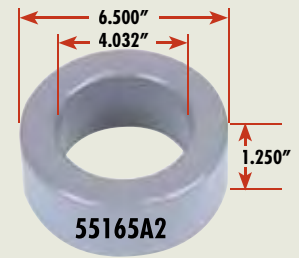

Permeability (μ)	$A_L \pm 8\%$	Part Number			
		MPP	High Flux	Kool M μ [®]	XFLUX [®]
14	42	55164	58164	-	-
26	78	55165	58165	77165	-
40	120	-	-	77166	-
60	180	55167	58167	-	-

Physical Characteristics	
Window Area	8,030 mm ²
Cross Section	987 mm ²
Path Length	412 mm
Volume	407,000 mm ³
Weight- MPP*	3,000 g
Weight- High Flux*	2,800 g
Weight- Kool M μ * [*]	2,200 g
Weight - XFLUX	-
Area Product	7,920,000 mm ⁴

Wound Coil Dimensions	
Max OD (70%)	228 mm
Max HT (70%)	103 mm

*26 μ , see page 3-2

Winding Turn Length [*] Reference General Winding Data pages	
WINDING FACTOR	LENGTH/TURN (mm)
0%	132
20%	158
25%	164
30%	170
35%	178
40%	184
45%	192
50%	199
60%	215
70%	233

Surface Area	
Unwound Core	55,400 mm ²
40% Winding Factor	101,000 mm ²

Kool M μ A_L vs. DC Bias

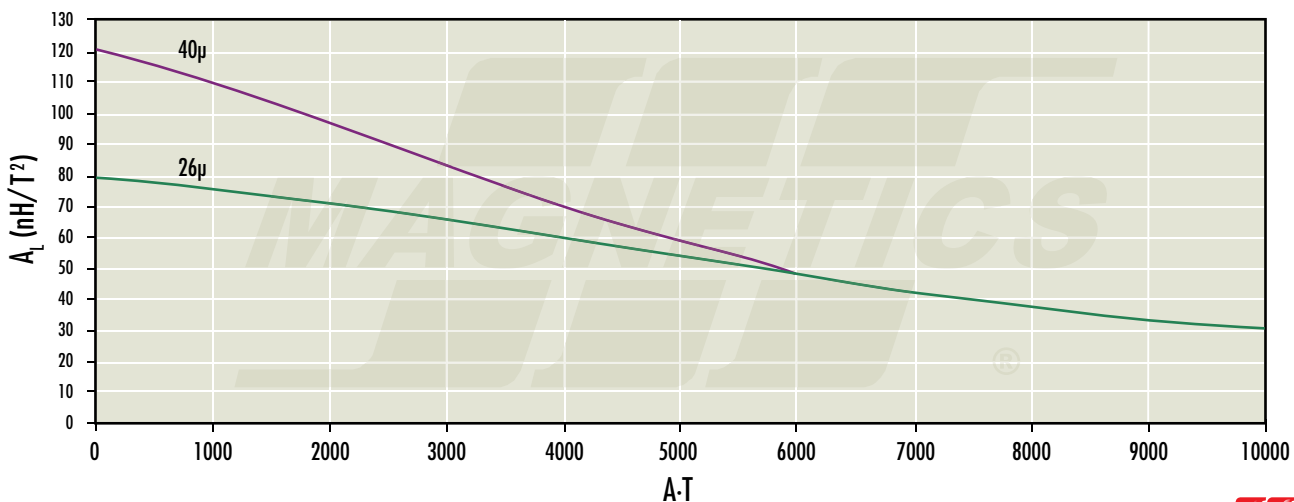

Kool M μ [®] E Core Data

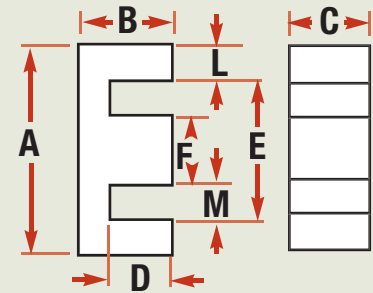

PART NO		A	B	C	D(min)	E(min)	F	L(nom)	M(min)
00M1207E (EF 12.6)	mm in	12.7±0.254 0.500±0.010	6.40±0.102 0.252±0.004	3.56±0.152 0.140±0.006	4.52 0.178	8.89 0.350	3.56±0.127 0.140±0.005	1.78 0.070	2.64 0.104
00K1808E (EI-187)	mm in	19.3±0.305 0.760±0.012	8.10±0.178 0.319±0.007	4.78±0.152 0.188±0.006	5.53 0.218	13.9 0.548	4.78±0.127 0.188±0.005	2.39 0.094	4.64 0.183
00K2510E (E-2425)	mm in	25.4±0.381 1.000±0.015	9.53±0.178 0.375±0.007	6.35±0.102 0.250±0.004	6.22 0.245	18.7 0.740	6.35±0.127 0.250±0.005	3.18 0.125	6.24 0.246
00K3007E (DIN 30/7)	mm in	30.10±0.457 1.185±0.018	15.0±0.229 0.591±0.009	7.06±0.152 0.278±0.006	9.55 0.376	19.8 0.782	6.96±0.203 0.274±0.008	5.11 0.201	6.32 0.249
00K3515E (EI-375)	mm in	34.54±0.508 1.360±0.020	14.2±0.229 0.557±0.009	9.35±0.178 0.368±0.007	9.60 0.378	25.2 0.995	9.32±0.203 0.367±0.008	4.45 0.175	7.87 0.310
00K4017E (EE 42/11)	mm in	42.85±0.635 1.687±0.025	21.1±0.305 0.830±0.012	10.8±0.254 0.424±0.010	14.9 0.587	30.30 1.195	11.9±0.254 0.468±0.010	5.94 0.234	9.27 0.365
00K4020E (DIN 42/15)	mm in	42.85±0.635 1.687±0.025	21.1±0.330 0.830±0.013	15.4±0.254 0.608±0.010	14.9 0.587	30.35 1.195	11.9±0.254 0.468±0.010	5.94 0.234	9.27 0.365
00K4022E (DIN 42/20)	mm in	42.85±0.635 1.687±0.025	21.1±0.330 0.830±0.013	20.0±0.254 0.788±0.010	14.9 0.587	30.35 1.195	11.9±0.254 0.468±0.010	5.94 0.234	9.27 0.365
00K4317E (EI-21)	mm in	40.87±0.610 1.609±0.024	16.5±0.279 0.650±0.011	12.5±0.178 0.493±0.007	10.3 0.409	28.32 1.115	12.5±0.203 0.493±0.008	6.05 0.238	7.87 0.310
00K5528E (DIN 55/21)	mm in	54.86±0.813 2.160±0.032	27.56±0.406 1.085±0.016	20.6±0.381 0.812±0.015	18.5 0.729	37.49 1.476	16.8±0.381 0.660±0.015	8.38 0.330	10.2 0.405
00K5530E (DIN 55/25)	mm in	54.86±0.813 2.160±0.032	27.56±0.406 1.085±0.016	24.6±0.381 0.969±0.015	18.5 0.729	37.49 1.476	16.8±0.381 0.660±0.015	8.38 0.330	10.2 0.405
00K6527E (Metric E65)	mm in	65.15±1.27 2.565±0.050	32.51±0.381 1.280±0.015	27.00±0.406 1.063±0.016	22.1 0.874	44.19 1.740	19.7±0.356 0.774±0.014	10.0 0.394	12.0 0.476
00K7228E (F11)	mm in	72.39±1.09 2.85±0.043	27.94±0.508 1.100±0.020	19.1±0.381 0.750±0.015	17.7 0.699	52.62 2.072	19.1±0.381 0.750±0.015	9.53 0.375	16.8 0.665
00K8020E (Metric E80)	mm in	80.01±1.19 3.150±0.047	38.10±0.635 1.500±0.025	19.8±0.381 0.780±0.015	28.01 1.103	59.28 2.334	19.8±0.381 0.780±0.015	9.91 0.390	19.8 0.780
00K8044E	mm in	80.01±1.19 3.150±0.047	44.58±0.635 1.755±0.025	19.8±0.381 0.780±0.015	34.36 1.353	59.28 2.334	19.8±0.381 0.780±0.015	9.91 0.390	19.8 0.780
00K130LE	mm in	130.3±3.81 5.130±0.150	32.51±0.305 1.280±0.012	53.85±1.27 2.120±0.050	22.1 0.874	108.4 4.270	20.0±0.762 0.788±0.030	10.0 0.394	44.22 1.741
00K160LE	mm in	160.0±2.54 6.300±0.100	38.10±0.635 1.500±0.025	39.62±1.27 1.560±0.050	28.14 1.108	138.2 5.440	19.8±0.762 0.780±0.030	9.91 0.390	59.28 2.334

Kool M μ [®] E Core Data

PART NO	A _l nH/TURNS \pm 8%				Path Length l _e (mm)	Cross Section A _e (mm ²)	Volume V _e (mm ³)
	26 μ	40 μ	60 μ	90 μ			
00M1207E***	-	-	-	-	29.6	13.0	385
00K1808E***	26	35	48	69	40.1	22.8	914
00K2510E***	39	52	70	100	48.5	38.5	1,870
00K3007E***	33	46	71	92	65.6	60.1	3,940
00K3515E***	56	75	102	146	69.4	84.0	5,830
00K4017E***	56	76	105	151	98.4	128	12,600
00K4020E***	80	108	150	217	98.4	183	18,000
00K4022E***	104	140	194	281	98.4	237	23,300
00K4317E***	88	119	163	234	77.5	152	11,800
00K5528E***	116	157	219	-	123	350	43,100
00K5530E***	138	187	261	-	123	417	51,300
00K6527E***	162	230	300	-	147	540	79,400
00K7228E***	130	173	235	-	137	368	50,400
00K8020E***	103	145	190	-	185	389	72,000
00K8044E***	91	-	-	-	208	389	80,900
00K130LE***	254	-	-	-	219	1080	237,000
00K160LE***	180	-	-	-	273	778	212,000

*** Add material code to part number, e.g., for 60 μ the complete part number is 00K1808E060

Kool M μ [®] Blocks

PART NO		A	B	C	Volume V _e (mm ³)
00K4741B***	mm	47.50 \pm 0.61	41.00 \pm 0.51	27.51 \pm 0.41	53,600 mm ³
	in	1.870 \pm 0.024	1.614 \pm 0.020	1.083 \pm 0.016	
00K5528B***	mm	54.86 \pm 0.64	27.56 \pm 0.41	20.6 \pm 0.39	31,200 mm ³
	in	2.160 \pm 0.025	1.085 \pm 0.016	0.812 \pm 0.015	
00K6030B***	mm	60.00 \pm 0.25	30.00 \pm 0.25	15.0 \pm 0.25	27,000 mm ³
	in	2.362 \pm 0.01	1.181 \pm 0.01	0.591 \pm 0.01	

*** Standard blocks are available in 26 μ . For other permeabilities, contact Application Engineering.

Kool M μ [®] U Core Data

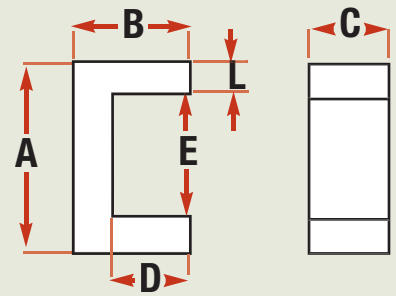

PART NO		A	B	C	D(min)	E(min)	L(nom)
00K3112U***	mm in	31.24±0.51 1.230±0.020	11.2±0.26 0.440±0.010	12.1±0.39 0.475±0.015	2.54 0.100	14.2 0.560	8.26 0.325
00K4110U***	mm in	40.64±0.51 1.600±0.020	11.2±0.51 0.440±0.020	9.53±0.39 0.375±0.015	2.54 0.100	23.6 0.930	8.38 0.330
00K4111U***	mm in	40.64±0.51 1.600±0.020	11.2±0.26 0.440±0.010	12.1±0.39 0.475±0.015	2.54 0.100	23.6 0.930	8.38 0.330
00K4119U***	mm in	40.64±0.51 1.600±0.020	11.2±0.26 0.440±0.010	19.1±0.39 0.750±0.015	2.54 0.100	23.6 0.930	8.38 0.330
00K5527U***	mm in	54.86±0.64 2.160±0.025	27.56±0.41 1.085±0.016	16.3±0.39 0.643±0.015	16.7 0.660	33.78 1.330	10.5 0.415
00K5529U***	mm in	54.86±0.64 2.160±0.025	27.56±0.51 1.085±0.020	23.2±0.39 0.912±0.015	16.5 0.650	33.02 1.300	10.5 0.415
00K6527U***	mm in	65.15±1.4 2.565±0.053	32.51±0.31 1.280±0.012	27.00±0.41 1.063±0.016	22.1 0.874	44.22 1.741	10.0 0.394
00K6533U***	mm in	65.15±1.4 2.565±0.053	32.51±0.31 1.280±0.012	20.0±0.41 0.788±0.016	19.6 0.772	39.24 1.545	12.5 0.493
00K7236U***	mm in	72.39±0.89 2.850±0.035	35.56±0.64 1.400±0.025	20.9±0.39 0.821±0.015	21.3 0.841	43.68 1.720	13.9 0.547
00K8020U***	mm in	80.01±0.89 3.150±0.035	38.10±0.64 1.500±0.025	19.8±0.39 0.780±0.015	28.14 1.108	59.28 2.334	9.91 0.390
00K8038U***	mm in	80.01±0.89 3.150±0.035	38.10±0.64 1.500±0.025	23.0±0.39 0.907±0.015	22.4 0.883	49.27 1.940	15.4 0.605

PART NO	A _L nH/TURN ² ± 8%				Path Length l _e (mm)	Cross Section A _e (mm ²)	Volume V _e (mm ³)
	26μ	40μ	60μ	90μ			
00K3112U***	-	92	111	179	65.6	101	6,630
00K4110U***	-	56	78	109	85.2	80.0	6,820
00K4111U***	-	72	95	138	85.2	101	8,600
00K4119U***	-	110	151	218	85.2	159	13,600
00K5527U***	67	-	-	-	168	172	28,900
00K5529U***	85	-	-	-	168	244	41,000
00K6527U***	89	-	-	-	219	270	59,100
00K6533U***	82	-	-	-	199	250	49,800
00K7236U***	87	-	-	-	219	290	63,500
00K8020U***	64	-	-	-	273	195	53,200
00K8038U***	97	-	-	-	237	354	83,900

Kool M μ [®] Segments

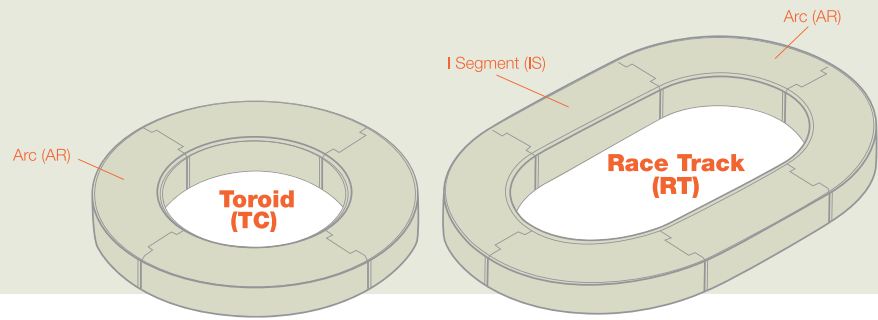

PART NO	Geometry	Perm		OD	ID	Ht	Length	L _e (mm)	A _e (mm ²)	V _e (mm ³)	A _L nH/TURNS ² ± 8%
00K102TC026	TOROID	26	mm in	102 4.00	57.2 2.25	16.5 0.65	NA NA	243	356	86,500	48
	RT (Race Track)	26	mm in	102 4.00	57.2 2.25	16.5 0.65	159 6.25	357	356	127,000	30
00K102AR026	AR (Arc)	26									
00K102IS0026	IS (I Segment)	26	mm in	NA NA	NA NA	16.51 0.65	57.15 2.25	NA	NA	NA	NA
00K133TC026	TOROID	26	mm in	133 5.22	78.6 3.09	25.4 1.00	NA NA	324	669	217,000	68
00K133RT026	RT (Race Track)	26	mm in	133 5.22	78.6 3.09	25.4 1.00	209 8.22	477	669	319,000	46
00K133AR026	AR (Arc)	26									
00K133IS026	IS (I Segment)	26	mm in	NA NA	NA NA	25.4 1.00	76.2 3.00	NA	NA	NA	NA

Kool M μ parts listed. MPP and High Flux cores also available in select permeabilities.

Kool M μ [®] Shapes, DC Bias

Kool M μ E shapes are available in four permeabilities, 26 μ , 40 μ , 60 μ , and 90 μ . The magnetic data for each core is shown on pages 4-32 through 4-34. The most critical parameter of a switching regulator inductor material is its ability to provide inductance, or permeability, under DC bias. The graph below shows the reduction of permeability as a function of DC bias. The distributed air gap

of Kool M μ results in a soft inductance versus DC bias curve. In most applications, this swinging inductance is desirable since it maximizes power handling for a given package size; improves efficiency; accommodates a wide operating range; and provides automatic fault or overload protection.

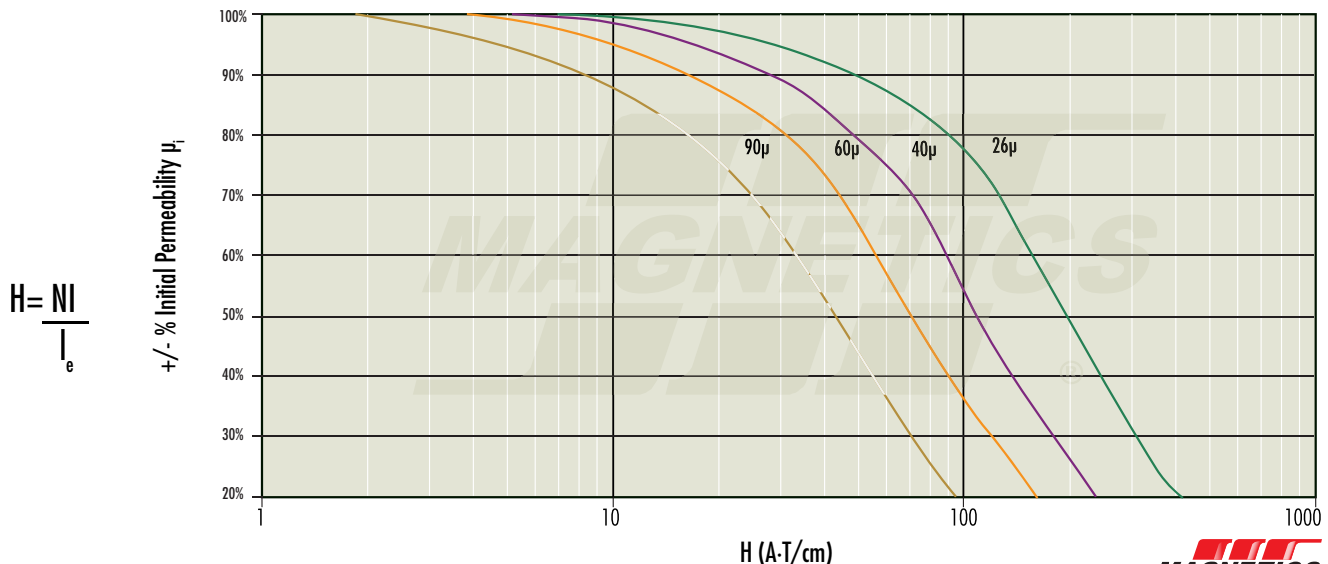

MPP THINZ[®] Core Data

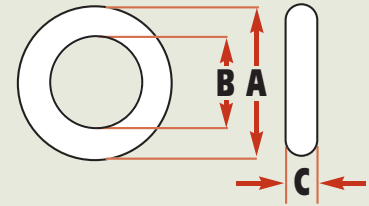

Special core heights are available, consult Magnetics.

PART NO		A nom	B nom	C nom	A max	B min	C max
00M0301T***	mm in	3.05 0.120	1.78 0.070	0.81 0.032	3.18 0.125	1.70 0.067	0.89 0.035
00M0302T***	mm in	3.55 0.140	1.78 0.070	0.81 0.032	3.69 0.145	1.70 0.067	0.89 0.035
00M0402T***	mm in	3.94 0.155	2.23 0.088	0.81 0.032	4.07 0.160	2.13 0.084	0.89 0.035
00M0502T***	mm in	4.60 0.181	2.36 0.093	0.81 0.032	4.73 0.186	2.26 0.089	0.89 0.035
00M0603T***	mm in	6.35 0.250	2.79 0.110	0.81 0.032	6.48 0.255	2.67 0.105	0.89 0.035
00M0804T***	mm in	7.87 0.310	3.96 0.156	0.81 0.032	8.03 0.316	3.83 0.151	0.89 0.035

PART NO	A_i nH/TURN ² ± 15%				Path Length l_e (mm)	Cross Section A_e (mm ²)	Volume V_e (mm ³)
	125 μ	160 μ	200 μ	250 μ			
00M0301T***	8.4	10.8	13.5	16.9	7.04	0.40	2.8
00M0302T***	11.6	14.8	18.7	23.4	8.06	0.60	4.8
00M0402T***	9.6	12.3	15.4	19.3	9.44	0.58	5.5
00M0502T***	11.7	15.0	18.7	23.4	10.6	0.79	8.3
00M0603T***	14.9	19.1	24.0	30.0	13.6	1.30	17.7
00M0804T***	12.6	16.2	20.2	25.3	17.9	1.45	25.9

***Add material code to part number, e.g., for 125 μ the complete part number is 00M0502T125

MPP THINZ[®] Core Data

MPP THINZ DC Bias

THINZ are available in four permeabilities, 125 μ , 160 μ , 200 μ , and 250 μ , but the product is designed to be easily customized to any permeability up to 250. The most critical parameter of a power inductor material is its ability to provide inductance, or permeability, under DC bias. The distributed air gap of MPP results in a soft inductance versus DC bias curve. This swinging inductance is often desirable since it maximizes power handling for a given package size; improves efficiency; accommodates a

wide operating range; and provides automatic fault or overload protection. The following equation can be used to relate current to magnetizing force, or H.

$$H = NI/l_g$$

where:

H = DC Magnetizing force in amp-turns/cm

N = number of turns

I = current in amps

l_g = magnetic path length in cm

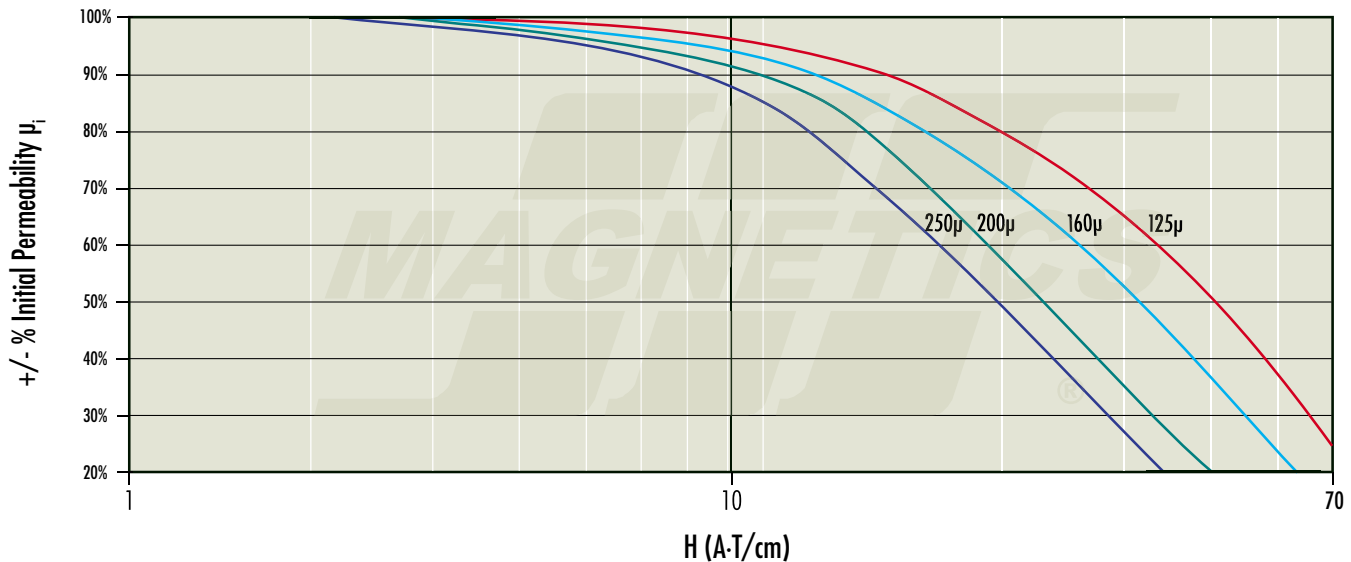

Kool M μ E Core Hardware

Magnetics has bobbins available for use with Kool M μ E cores. Refer to Magnetics Ferrite Cores catalog for a complete listing of available bobbins. The cores are standard industry sizes that will fit standard bobbins available from many sources. Core pieces can be assembled by bonding the mating surfaces or taping around the perimeter of the core set. Caution is advised if metal clamps are considered, since eddy current heating can occur in conductive material that is very close to the surface of low permeability Kool M μ Material.

Core Number	Bobbin Number	Number of Pins	Winding Area	Length Per Turn
			(mm ²)	(mm)
OOK10808E (EI-187)	PCB1808B1	8	31.6	40.5
	OOB180801	-	34.2	39.4
OOK2510E (E-2425)	PCB2510V1	10	40.6	54.2
	PCB2510V2	10	20.3	54.2
	OOB251001	-	51	45.4
OOK3007E (DIN 30/7)	PCB3007T1	10	83.3	55
OOK3515E (EI-375)	PCB3515M1	12	94.8	73.4
	PCB3515M2	12	47.4	73.4
	OOB351501	-	113	72
OOK4020E (DIN 42/15)	PCB4020N1	12	194	91.4
	OOB402021	-	207	97.5
OOK4022E (DIN 42/20)	PCB4022N1	12	194	102.1
OOK4317E (EI-21)	PCB4317M1	12	101	85.6
	OOB431701	-	126	84.4
OOK5528E (DIN55/25)	PCB5528WC	14	302	107.3
	OOB5528B1	-	302	107.3
OOK5530E	PCB5530FA	14	289	133.8
OOK6527E	OOB652701	-	454	167.2
OOK7228E (F11)	OOB722801	-	408	149
OOK8020E (Metric E80)	OOB802001	-	806	165
	OOB802002	-	403	165

Hardware

TVB22066A

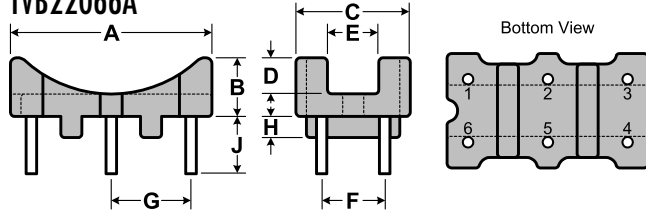

For use with toroids from 12.7 mm through 22.2 mm

Material	6 Pins	A Nom.	B Nom.	C Nom.	D Nom.	E Ref.	F Typ.	G Typ.	H Ref.	J Ref.
Phenolic rated UL94V0	CP wire 0.99 mm	19.0 mm	5.44 mm	10.8 mm	3.51 mm	4.80 mm	6.00 mm	7.49 mm	2.01 mm	5.49 mm

TVB2908TA

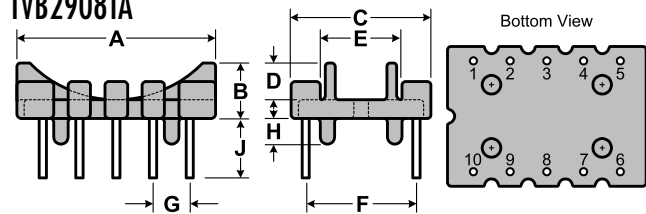

For use with toroids from 20.5 mm through 31.8 mm

Material	10 Pins	A Nom.	B Nom.	C Nom.	D Nom.	E Ref.	F Typ.	G Typ.	H Ref.	J Ref.
Phenolic rated UL94V0	CP wire 0.99 mm	27.0 mm	7.49 mm	19.0 mm	5.00 mm	11.0 mm	15.0 mm	5.00 mm	3.51 mm	8.13 mm

TVB3610FA

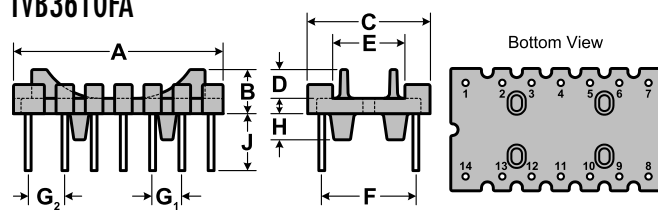

For use with toroids from 28.6 mm through 38.1 mm

Material	14 Pins	A Nom.	B Nom.	C Nom.	D Nom.	E Ref.	F Typ.	G ₁ Typ.	G ₂ Typ.	H Ref.	J Ref.
Phenolic rated UL94V0	CP wire 0.99 mm	35.8 mm	7.59 mm	20.8 mm	5.00 mm	12.3 mm	16.0 mm	5.00 mm	6.30 mm	4.5 mm	9.75 mm

TVH22064A

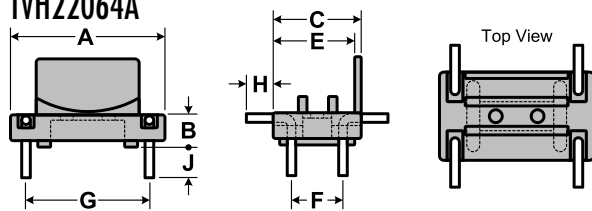

For use with toroids from 12.7 mm through 25.4 mm

Material	4 Pins	A Nom.	B Nom.	C Nom.	E Ref.	F Typ.	G Typ.	H Ref.	J Ref.
Nylon 6/6 rated UL94V0	CP wire 1.02 mm	19.1 mm	3.94 mm	10.8 mm	9.78 mm	6.35 mm	15.2 mm	3.30 mm	3.81 mm

Hardware

TVH25074A

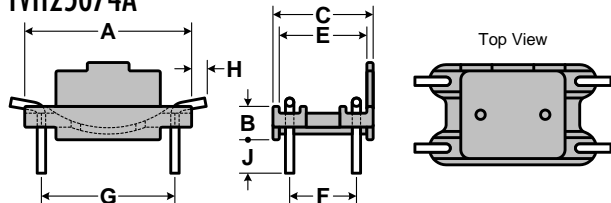

For use with toroids from 20.5 mm (0.810") through 30.5 mm

Material	4 Pins	A Nom.	B Nom.	C Nom.	E Ref.	F Typ.	G Typ.	H Ref.	J Ref.
Nylon 6/6 rated UL94V0	CP wire 1.27 mm	25.4 mm	5.08 mm	15.2 mm	13.0 mm	10.2 mm	20.3 mm	2.29 mm	5.08 mm

TVH38134A

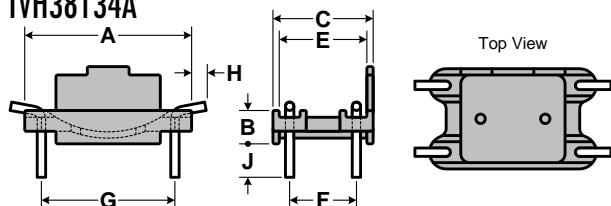

For use with toroids from 25.4 mm (1.000") through 40.6 mm

Material	4 Pins	A Nom.	B Nom.	C Nom.	E Ref.	F Typ.	G Typ.	H Ref.	J Ref.
Nylon 6/6 rated UL94V0	CP wire 1.27 mm	27.9 mm	5.08 mm	20.3 mm	18.0 mm	15.2 mm	22.9 mm	2.29 mm	5.08 mm

TVH49164A

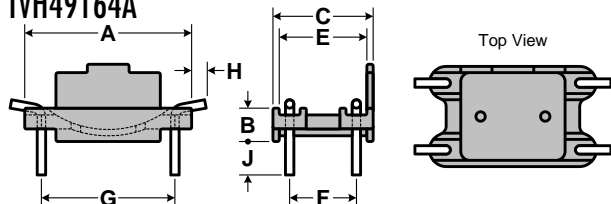

For use with toroids from 38.1 mm through 63.5 mm

Material	4 Pins	A Nom.	B Nom.	C Nom.	E Ref.	F Typ.	G Typ.	H Ref.	J Ref.
Nylon 6/6 rated UL94V0	CP wire 1.27 mm	35.6 mm	5.08 mm	22.9 mm	20.6 mm	17.8 mm	30.5 mm	2.29 mm	5.08 mm

TVH61134A

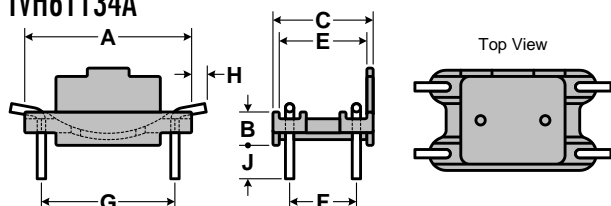

For use with toroids from 44.4 mm through 71.1 mm

Material	4 Pins	A Nom.	B Nom.	C Nom.	E Ref.	F Typ.	G Typ.	H Ref.	J Ref.
Nylon 6/6 rated UL94V0	CP wire 1.27 mm	43.2 mm	5.08 mm	27.9 mm	25.7 mm	22.9 mm	38.1 mm	2.29 mm	5.08 mm

Winding Tables

3.56 mm OD (140 size)

AWG Wire Size	Single Layer Turns	Single Layer R_{DC} (Ohms, Ω)
30	10	0.0286
31	11	0.0392
32	13	0.0567
33	15	0.0821
34	17	0.119
35	20	0.172
36	23	0.246
37	25	0.328
38	28	0.461
39	33	0.704
40	38	1.03
41	43	1.42
42	49	2.01
43	55	2.91
44	59	3.76
45	69	5.65
46	76	7.80
47	85	11.0
48	98	16.0
49	109	22.2

6.35 mm OD (020 size)

AWG Wire Size	Single Layer Turns	Single Layer R_{DC} (Ohms, Ω)
26	12	0.0216
27	14	0.0312
28	16	0.0446
29	18	0.0617
30	21	0.0910
31	23	0.125
32	26	0.173
33	30	0.252
34	34	0.367
35	39	0.518
36	44	0.729
37	48	0.977
38	54	1.39
39	62	2.07
40	71	3.00
41	80	4.13
42	91	5.87
43	101	8.40
44	110	11.1
45	128	16.6

6.86 mm OD (410 size)

AWG Wire Size	Single Layer Turns	Single Layer R_{DC} (Ohms, Ω)
22	12	0.0116
23	14	0.0168
24	16	0.0239
25	18	0.0334
26	20	0.0465
27	23	0.0663
28	26	0.0942
29	29	0.129
30	33	0.187
31	37	0.262
32	41	0.358
33	47	0.518
34	53	0.752
35	60	1.05
36	67	1.47
37	74	1.99
38	83	2.82
39	96	4.24
40	109	6.11
41	122	8.37

3.94 mm OD (150 size)

AWG Wire Size	Single Layer Turns	Single Layer R_{DC} (Ohms, Ω)
28	11	0.0251
29	13	0.0364
30	15	0.0529
31	17	0.0749
32	19	0.103
33	22	0.149
34	25	0.218
35	28	0.300
36	32	0.427
37	35	0.574
38	40	0.826
39	46	1.23
40	53	1.80
41	59	2.44
42	68	3.52
43	76	5.06
44	82	6.60
45	96	9.93
46	105	13.6
47	117	19.1

6.60 mm OD (240 size)

AWG Wire Size	Single Layer Turns	Single Layer R_{DC} (Ohms, Ω)
26	11	0.0196
27	13	0.0287
28	15	0.0414
29	17	0.0577
30	19	0.0815
31	22	0.118
32	25	0.165
33	28	0.233
34	32	0.342
35	36	0.473
36	41	0.672
37	45	0.907
38	51	1.30
39	58	1.92
40	67	2.80
41	75	3.84
42	85	5.43
43	95	7.82
44	103	10.3
45	121	15.5

7.87 mm OD (030 size)

AWG Wire Size	Single Layer Turns	Single Layer R_{DC} (Ohms, Ω)
22	12	0.00988
23	14	0.0142
24	16	0.0201
25	18	0.0281
26	20	0.0390
27	23	0.0556
28	26	0.0787
29	29	0.108
30	33	0.156
31	37	0.218
32	41	0.298
33	47	0.430
34	53	0.623
35	60	0.870
36	67	1.21
37	74	1.65
38	83	2.33
39	96	3.50
40	109	5.04
41	122	6.90

4.65 mm OD (180 size)

AWG Wire Size	Single Layer Turns	Single Layer R_{DC} (Ohms, Ω)
27	11	0.0212
28	12	0.0289
29	14	0.0414
30	16	0.0597
31	18	0.0838
32	20	0.114
33	23	0.165
34	27	0.249
35	31	0.352
36	34	0.481
37	38	0.661
38	43	0.942
39	50	1.42
40	57	2.05
41	64	2.82
42	73	4.01
43	81	5.73
44	88	7.52
45	103	11.3
46	113	15.6

6.60 mm OD (270 size)

AWG Wire Size	Single Layer Turns	Single Layer R_{DC} (Ohms, Ω)
26	11	0.0266
27	13	0.0390
28	15	0.0566
29	17	0.0790
30	19	0.112
31	22	0.163
32	25	0.228
33	28	0.322
34	32	0.474
35	36	0.658
36	41	0.936
37	45	1.26
38	51	1.81
39	58	2.68
40	67	3.92
41	75	5.37
42	85	7.61
43	95	11.0
44	103	14.4
45	121	21.8

9.65 mm OD (280 size)

AWG Wire Size	Single Layer Turns	Single Layer R_{DC} (Ohms, Ω)
20	12	0.00684
21	13	0.00914
22	15	0.0131
23	18	0.0194
24	20	0.0268
25	23	0.0383
26	26	0.0541
27	29	0.0747
28	33	0.107
29	37	0.147
30	42	0.212
31	47	0.297
32	52	0.404
33	58	0.568
34	67	0.844
35	75	1.17
36	84	1.63
37	92	2.19
38	104	3.13
39	119	4.66

Winding Tables

9.65 mm OD (290 size)

AWG Wire Size	Single Layer Turns	Single Layer R _{DC} (Ohms, Ω)
20	12	0.00747
21	13	0.0100
22	15	0.0144
23	18	0.0213
24	20	0.0295
25	23	0.0421
26	26	0.0596
27	29	0.0825
28	33	0.118
29	37	0.163
30	42	0.234
31	47	0.328
32	52	0.448
33	58	0.630
34	67	0.937
35	75	1.29
36	84	1.81
37	92	2.44
38	104	3.48
39	119	5.18

12.7 mm OD (050 size)

AWG Wire Size	Single Layer Turns	Single Layer R _{DC} (Ohms, Ω)
16	12	0.00364
17	14	0.00520
18	16	0.00733
19	19	0.0107
20	21	0.0147
21	24	0.0207
22	28	0.0302
23	31	0.0413
24	35	0.0582
25	40	0.0829
26	45	0.117
27	50	0.161
28	56	0.227
29	63	0.315
30	71	0.451
31	79	0.629
32	87	0.854
33	98	1.21
34	112	1.79
35	125	2.46

20.3 mm OD (206 size)

AWG Wire Size	Single Layer Turns	Single Layer R _{DC} (Ohms, Ω)
11	12	0.00163
12	14	0.00232
13	16	0.00324
14	18	0.00449
15	21	0.00644
16	24	0.00909
17	27	0.0126
18	31	0.0179
19	35	0.0251
20	39	0.0347
21	45	0.0498
22	50	0.0692
23	56	0.0962
24	63	0.135
25	71	0.191
26	80	0.270
27	89	0.374
28	100	0.529
29	111	0.725
30	125	1.04

10.2 mm OD (040 size)

AWG Wire Size	Single Layer Turns	Single Layer R _{DC} (Ohms, Ω)
20	13	0.00818
21	15	0.0117
22	17	0.0165
23	19	0.0227
24	22	0.0328
25	25	0.0463
26	28	0.0650
27	31	0.0893
28	36	0.130
29	40	0.178
30	45	0.254
31	50	0.354
32	56	0.488
33	63	0.693
34	72	1.02
35	81	1.42
36	91	1.99
37	99	2.66
38	112	3.80
39	128	5.65

16.5 mm OD (120 size)

AWG Wire Size	Single Layer Turns	Single Layer R _{DC} (Ohms, Ω)
13	12	0.00234
14	14	0.00336
15	16	0.00471
16	18	0.00654
17	21	0.00940
18	24	0.0133
19	27	0.0185
20	30	0.0255
21	34	0.0359
22	39	0.0516
23	44	0.0722
24	49	0.101
25	56	0.143
26	63	0.203
27	70	0.280
28	78	0.393
29	87	0.542
30	98	0.775
31	108	1.07
32	121	1.48

22.9 mm OD (310 size)

AWG Wire Size	Single Layer Turns	Single Layer R _{DC} (Ohms, Ω)
10	12	0.00148
11	14	0.00212
12	16	0.00296
13	18	0.00409
14	21	0.00589
15	24	0.00830
16	27	0.0116
17	31	0.0164
18	35	0.0230
19	39	0.0319
20	44	0.0446
21	50	0.0632
22	56	0.0888
23	63	0.124
24	70	0.173
25	79	0.244
26	89	0.345
27	99	0.479
28	111	0.677
29	123	0.927

11.2 mm OD (130 size)

AWG Wire Size	Single Layer Turns	Single Layer R _{DC} (Ohms, Ω)
16	10	0.00272
17	11	0.00366
18	13	0.00532
19	15	0.00756
20	17	0.0106
21	20	0.0153
22	23	0.0220
23	25	0.0295
24	29	0.0426
25	33	0.0602
26	37	0.0845
27	41	0.116
28	46	0.164
29	52	0.228
30	59	0.328
31	65	0.453
32	72	0.618
33	81	0.877
34	93	1.30
35	104	1.79

17.3 mm OD (380 size)

AWG Wire Size	Single Layer Turns	Single Layer R _{DC} (Ohms, Ω)
13	11	0.00223
14	13	0.00324
15	15	0.00460
16	17	0.00644
17	20	0.00933
18	22	0.0127
19	25	0.0179
20	29	0.0258
21	32	0.0354
22	37	0.0512
23	41	0.0704
24	46	0.099
25	52	0.139
26	59	0.199
27	66	0.277
28	74	0.391
29	82	0.535
30	92	0.764
31	102	1.06
32	114	1.47

23.6 mm OD (350 size)

AWG Wire Size	Single Layer Turns	Single Layer R _{DC} (Ohms, Ω)
9	11	0.00120
10	13	0.00173
11	15	0.00244
12	17	0.00340
13	19	0.00467
14	22	0.00668
15	25	0.00938
16	28	0.0130
17	32	0.0184
18	36	0.0258
19	41	0.0365
20	46	0.0510
21	51	0.0705
22	58	0.101
23	65	0.140
24	73	0.197
25	82	0.277
26	92	0.392
27	102	0.542
28	115	0.770

Winding Tables

26.9 mm OD (930 size)

AWG Wire Size	Single Layer Turns	Single Layer R_{DC} (Ohms, Ω)
9	11	0.00141
10	13	0.00205
11	15	0.00292
12	17	0.00407
13	20	0.00592
14	22	0.00808
15	25	0.0114
16	29	0.0164
17	33	0.0232
18	37	0.0324
19	42	0.0459
20	47	0.0640
21	53	0.0902
22	60	0.128
23	66	0.176
24	75	0.251
25	84	0.352
26	94	0.497
27	105	0.693
28	117	0.975

35.8 mm OD (324 size)

AWG Wire Size	Single Layer Turns	Single Layer R_{DC} (Ohms, Ω)
8	16	0.00169
9	19	0.00246
10	22	0.00351
11	25	0.00491
12	28	0.00677
13	32	0.00955
14	36	0.0133
15	41	0.0188
16	46	0.0263
17	52	0.0369
18	58	0.0514
19	65	0.0718
20	73	0.1
21	82	0.141
22	93	0.201
23	103	0.277
24	116	0.392
25	130	0.551
26	146	0.78
27	162	1.08

46.7 mm OD (089 size)

AWG Wire Size	Single Layer Turns	Single Layer R_{DC} (Ohms, Ω)
8	22	0.00296
9	26	0.00432
10	29	0.00596
11	33	0.00840
12	38	0.0120
13	42	0.0164
14	47	0.0229
15	54	0.0327
16	60	0.0455
17	68	0.0641
18	76	0.0897
19	86	0.127
20	96	0.177
21	108	0.249
22	121	0.352
23	135	0.490
24	151	0.690
25	170	0.975
26	190	1.37
27	211	1.91

33.0 mm OD (548 size)

AWG Wire Size	Single Layer Turns	Single Layer R_{DC} (Ohms, Ω)
8	14	0.00147
9	17	0.00218
10	19	0.00299
11	22	0.00427
12	25	0.00598
13	28	0.00826
14	32	0.0117
15	36	0.0163
16	41	0.0232
17	46	0.0322
18	52	0.0455
19	58	0.0632
20	65	0.0883
21	74	0.126
22	83	0.177
23	92	0.245
24	103	0.344
25	116	0.485
26	131	0.691
27	145	0.954

39.9 mm OD (254 size)

AWG Wire Size	Single Layer Turns	Single Layer R_{DC} (Ohms, Ω)
8	18	0.00229
9	21	0.00329
10	24	0.00464
11	27	0.00646
12	31	0.00917
13	35	0.0128
14	39	0.0178
15	44	0.0250
16	50	0.0354
17	56	0.0493
18	63	0.0695
19	71	0.0978
20	80	0.138
21	90	0.194
22	101	0.274
23	112	0.379
24	126	0.536
25	141	0.753
26	158	1.06
27	175	1.47

50.8 mm OD (715 size)

AWG Wire Size	Single Layer Turns	Single Layer R_{DC} (Ohms, Ω)
8	25	0.00324
9	29	0.00463
10	33	0.00651
11	37	0.00904
12	42	0.0127
13	47	0.0176
14	53	0.0247
15	60	0.0348
16	67	0.0486
17	76	0.0685
18	85	0.0959
19	95	0.134
20	107	0.189
21	120	0.265
22	135	0.375
23	150	0.520
24	168	0.732
25	189	1.03
26	211	1.46
27	234	2.02

34.3 mm OD (585 size)

AWG Wire Size	Single Layer Turns	Single Layer R_{DC} (Ohms, Ω)
8	17	0.00160
9	20	0.00229
10	23	0.00323
11	26	0.00449
12	30	0.00636
13	34	0.00887
14	38	0.0123
15	43	0.0172
16	48	0.0238
17	54	0.0332
18	61	0.0467
19	69	0.0657
20	77	0.0913
21	87	0.1287
22	98	0.1821
23	109	0.2519
24	122	0.354
25	137	0.497
26	153	0.699
27	170	0.969

46.7 mm OD (438 size)

AWG Wire Size	Single Layer Turns	Single Layer R_{DC} (Ohms, Ω)
8	18	0.00280
9	21	0.00405
10	24	0.00573
11	27	0.00801
12	31	0.0114
13	35	0.0160
14	39	0.0223
15	44	0.0314
16	50	0.0446
17	56	0.0622
18	63	0.0878
19	71	0.124
20	80	0.175
21	90	0.246
22	101	0.349
23	112	0.483
24	126	0.683
25	141	0.961
26	158	1.36
27	175	1.88

57.2 mm OD (195 size)

AWG Wire Size	Single Layer Turns	Single Layer R_{DC} (Ohms, Ω)
8	20	0.00322
9	23	0.00458
10	26	0.00642
11	30	0.00921
12	34	0.0130
13	39	0.0185
14	43	0.0254
15	49	0.0362
16	55	0.0508
17	62	0.0714
18	70	0.101
19	78	0.141
20	88	0.199
21	99	0.281
22	111	0.398
23	124	0.555
24	138	0.777
25	156	1.10
26	174	1.56
27	193	2.16

Winding Tables

57.2 mm OD (109 size)

AWG Wire Size	Single Layer Turns	Single Layer R_{DC} (Ohms, Ω)
8	29	0.00397
9	33	0.00558
10	37	0.00773
11	42	0.0109
12	48	0.0154
13	54	0.0215
14	60	0.0297
15	68	0.0420
16	76	0.0586
17	85	0.0816
18	96	0.115
19	108	0.162
20	120	0.225
21	135	0.318
22	152	0.451
23	169	0.625
24	189	0.880
25	212	1.24
26	238	1.76
27	263	2.43

77.8 mm OD (866 size)

AWG Wire Size	Single Layer Turns	Single Layer R_{DC} (Ohms, Ω)
8	41	0.00607
9	47	0.00860
10	53	0.0120
11	60	0.0169
12	67	0.0234
13	76	0.0329
14	85	0.0459
15	95	0.0640
16	107	0.0901
17	120	0.126
18	135	0.178
19	151	0.248
20	169	0.348
21	189	0.487
22	212	0.689
23	236	0.958
24	264	1.35
25	296	1.90
26	331	2.68
27	367	3.72

132.6 mm OD (337 size)

AWG Wire Size	Single Layer Turns	Single Layer R_{DC} (Ohms, Ω)
6	54	0.00890
7	61	0.0124
8	69	0.0175
9	78	0.0247
10	87	0.0344
11	99	0.0489
12	111	0.0685
13	124	0.0956
14	138	0.133
15	155	0.188
16	174	0.265
17	195	0.371
18	218	0.522
19	244	0.733
20	273	1.03
21	306	1.45
22	343	2.05
23	381	2.85
24	426	4.02
25	478	5.68

62.0 mm OD (620 size)

AWG Wire Size	Single Layer Turns	Single Layer R_{DC} (Ohms, Ω)
6	20	0.00260
7	23	0.00368
8	26	0.00517
9	30	0.00741
10	34	0.0104
11	38	0.0146
12	43	0.0205
13	49	0.0291
14	54	0.0402
15	61	0.0568
16	69	0.0805
17	78	0.114
18	87	0.159
19	98	0.225
20	110	0.316
21	123	0.444
22	138	0.629
23	154	0.878
24	172	1.24
25	194	1.75

77.8 mm OD (906 size)

AWG Wire Size	Single Layer Turns	Single Layer R_{DC} (Ohms, Ω)
8	41	0.00660
9	47	0.00937
10	53	0.0131
11	60	0.0184
12	67	0.0256
13	76	0.0361
14	85	0.0504
15	95	0.0703
16	107	0.0991
17	120	0.139
18	135	0.195
19	151	0.274
20	169	0.383
21	189	0.538
22	212	0.761
23	236	1.06
24	264	1.49
25	296	2.10
26	331	2.96
27	367	4.11

165.1 mm OD (165 size)

AWG Wire Size	Single Layer Turns	Single Layer R_{DC} (Ohms, Ω)
6	72	0.0139
7	81	0.0193
8	91	0.0272
9	103	0.0384
10	115	0.0536
11	130	0.0759
12	145	0.106
13	163	0.149
14	182	0.209
15	204	0.293
16	228	0.412
17	256	0.579
18	286	0.814
19	320	1.14
20	358	1.61
21	401	2.26
22	449	3.21
23	499	4.46
24	558	6.29
25	625	8.86

74.1 mm OD (740 size)

AWG Wire Size	Single Layer Turns	Single Layer R_{DC} (Ohms, Ω)
6	29	0.00450
7	33	0.00632
8	38	0.00907
9	43	0.0128
10	49	0.0182
11	55	0.0255
12	62	0.0358
13	70	0.0505
14	78	0.0706
15	88	0.0997
16	98	0.139
17	110	0.196
18	124	0.277
19	139	0.390
20	155	0.546
21	174	0.769
22	195	1.09
23	217	1.52
24	243	2.14
25	273	3.03

101.6 mm OD (120 size)

AWG Wire Size	Single Layer Turns	Single Layer R_{DC} (Ohms, Ω)
6	38	0.00489
7	43	0.00682
8	49	0.00965
9	55	0.0135
10	62	0.0189
11	70	0.0266
12	79	0.0373
13	89	0.0524
14	99	0.0730
15	112	0.103
16	125	0.145
17	140	0.202
18	157	0.285
19	176	0.400
20	197	0.561
21	221	0.790
22	248	1.12
23	275	1.55
24	308	2.19
25	345	3.09

Other Products from Magnetics

Ferrites

Magnetics' ferrite cores are manufactured for a wide variety of applications. Magnetics has developed and produces the leading MnZn ferrite materials for power transformers, power inductors, wideband transformers, common mode chokes, and many other applications. In addition to offering the leading materials, other advantages of ferrites from Magnetics include: the full range of standard planar E, ER, and I cores; the widest range of toroid sizes in power and high permeability materials; a standard gapping to precise inductance or mechanical dimension; a wide range of available coil formers and assembly hardware; and superior toroid coatings available in several options.

Power Materials

Five low loss materials are engineered for optimum frequency and temperature performance in power applications. Magnetics' R, P, F L, and T materials provide superior saturation, high temperature performance, low losses and product consistency.

SHAPES: E cores, Planar E cores, ER cores, ETD, EC, U cores, I cores, PQ, Planar PQ, RM, Toroids (2 mm to 140 mm), Pot cores, RS (round-slab), DS (double slab), EP, Special Shapes

APPLICATIONS: Telecomm power supplies, Computer power supplies, Commercial power supplies, Consumer power supplies, Automotive, DC-DC converters, Telecomm data interfaces, Impedance matching transformers, Handheld devices, High power control (gate drive), Computer servers, Distributed power (DC-DC), EMI filters, Aerospace, Medical.

High Permeability Materials

Two high permeability materials (5000 μ J material and 10,000 μ W material) are engineered for optimum frequency and impedance performance in signal, choke and filter applications. These Magnetics materials provide superior loss factor, frequency response, temperature performance, and product consistency.

SHAPES: Toroids (2 mm to 140 mm), E cores, U cores, RM, Pot cores, RS (round-slab), DS (double slab), EP, Special Shapes

APPLICATIONS: Common mode chokes, EMI filters, Other filters, Pulse transformers, Current transformers, Broadband transformers, Current sensors, Telecomm data interfaces, Impedance matching interfaces, Handheld devices, Spike suppression, Gate drive transformers

Strip Wound Cores

Tape wound cores are made from high permeability alloys of nickel-iron, grain oriented silicon-iron or cobalt-iron. The alloys are known as Orthonol[®], Alloy 48, Square Permalloy 80, Supermalloy, Magnesil[®] and Supermendur. Toroids are available in more than 50 standard sizes. For a wide range of frequency applications, materials are produced in thicknesses from 1/2 mil (0.013 mm) to 4 mils (0.1mm). Cores are cased in robust nylon, aluminum or phenolic boxes, rated for 200° C continuous operation and 2000 voltage minimum breakdown.

APPLICATIONS: Magnetic Amplifiers, Reactors, Regulators, Static Magnetic devices and Current Transformers.

Miniature Tape Wound Bobbin Cores are manufactured from Permalloy 80 and Orthonol ultra-thin tape (0.000125" to 0.001" thick). They are available in widths from 0.031" to 0.250". Wound on non-magnetic stainless steel bobbins, core diameters are available down to 0.050", with flux capacities as low as several maxwells.

APPLICATIONS: Magnetometers, Flux gates, Oscillators, Inverters and Magnetic amplifiers