

120W Adaptor

Demo Board Manual

(OB2203 + OB6563)

Key Features

- PFC is shut down when system goes to standby
- Standby power less than 0.29W under 240VAC no load
- High efficiency more than 87.7% under normal line with full load
- OCP with line compensation
- Programmable soft start
- Precise OVP
- Low components count
- Meet EN55022 EMI
- Pass 4kV surge test
- Pass 15kV/8kV ESD test

Index

1	Adaptor Module Specification	4
1.1	Input Characteristics	4
1.2	Output Characteristics	4
1.3	Performance Specifications	4
1.4	Soft Start	4
1.5	Protection Features	5
1.6	Environments	5
1.7	Dielectric withstand	5
1.8	Insulation	5
1.9	Leakage current	5
1.10	Printed circuit board	5
1.11	EMI	5
2	Adaptor Module Information	6
2.1	Schematic	6
2.2	PCB Gerber File	8
2.3	Bill of material	9
2.4	Transformer Design	11
2.4.1	Transformer Specification	11
2.4.2	Transformer Winding data	11
2.4.3	Boost Inductor Specicfication	12
2.4.4	Boost Inductor Winding data	12
2.5	Adaptor Module Snapshot	12
3	Performance Evaluation	14
3.1	Input Characteristics	15
3.1.1	Input Normal Characteristics	15
3.1.2	Input current and Standby power	16
3.1.3	Efficiency	16
3.2	Output Characteristics	17
3.2.1	Line Regulation & Load Regulation	17
3.2.2	Ripple & Noise	17
3.2.3	Overshoot & Undershoot	18
3.2.4	Dynamic Test	19
3.2.5	Time Sequence	20
3.3	Protections	22
3.3.1	Over Current Protection (OCP)	22
3.3.2	Over Voltage Protection (OVP)	22
3.3.3	Short Circuit Protection	22
3.4	EMI Test	23
3.4.1	Conducted EMI Test	23
3.4.2	Radiation EMI Test	23
3.5	ESD Test	25
3.6	Lighting Test	26
4	Other important waveform	27

4.1	Vdd, FB, Sense& Gate wave form at no load/25% load/50% load/full load.....	27
4.2	MOSFET VDS wave,Output diode VAK waveform at full load,start/normal/output short	28

Figures

Ripple & Noise waveform	18
Overshoot and Undershoot waveform	19
Dynamic waveform.....	20
Time Sequence waveform.....	21
Vdd,FB,Sense&Gate waveform.....	27
MOSFET VDS,CS&VAK start waveform.....	28
MOSFET VDS,CS&VAK normal operation waveform	28
MOSFET VDS,CS&VAK output short waveform.....	30

Tables

Table 1 Input current at full load.....	16
Table 2 Standby power at no load with LED (with PFC).....	16
Table 3 Efficiency with PFC part.....	16
Table 4 Line Regulation & Load Regulation	17
Table 5 Ripple & Noise measure results	17
Table 6 Overshoot/undershoot measurement results.....	18
Table 7 Output voltage under dynamic test.....	20
Table 8 Turn-on delay /hold-up/Rise time/Fall time measurement results.....	20
Table 9 OCP value vs. input voltage.....	22
Table 10 OVP test result.....	22
Table 11 SCP test result.....	23

1 Adaptor Module Specification

Model number: OBPD120W-H240A Rev.: 01

1.1 Input Characteristics

- AC input voltage rating 100Vac ~ 240Vac
- AC input voltage range 90Vac ~ 264Vac
- AC input frequency range 47Hz ~ 63Hz
- Inrush current at 25°C 25A maximum at 115VAC
50A maximum at 230VAC
- Input current 1.56 Arms max.

1.2 Output Characteristics

- Output Voltage 19.0V
- Output Tolerance $\pm 5\%$
- Min. load current 0A
- Max. load current 6.3A

1.3 Performance Specifications

- Max. Output Power 120W
- Standby Power <0.5W @ 240V/50Hz, no load
- Efficiency >85% @ normal line, full load, including power loss in input filters
- Line Regulation <1%
- Load Regulation <5%
- Ripple (Po: 10 to 90%) <350 mVpp
- Noise (F<640KHz) <200mVpp
- Hold up Time 16.7m Sec. Min. @100Vac with full load
- Turn on Delay Time 2 Sec. Max. @100Vac with full load

1.4 Soft Start

- Settling time <15ms to within 1% at nominal load
- Overshoot <3%

1.5 Protection Features

- Short circuit Protection Output shut down with automatic recovery
- Over Voltage Protection <25V
- Over Current Protection Output shut down with automatic recovery. The protection function will be enabled if output current exceeds 110%~140% of rated output current.

1.6 Environments

- Operating Temperature 0°C to +40°C
- Operating Humidity 20% to 90% R.H.
- Storage Temperature -40°C to +60°C
- Storage Humidity 0% to 95% R.H.

1.7 Dielectric withstand

The power supply shall withstand for 1 minute without breakdown by the application of a 60Hz 1500V AC voltage applied between both input line and ground (10mA DC cut-off current). Main transformer shall similarly withstand 3000Vac applied between both primary and secondary windings for a minimum of one minute.

1.8 Insulation

The insulation resistance should be not less than 30 MOHM after applying of 500VDC for 1 minute

1.9 Leakage current

The AC leakage current is less than 3.5mA when the power supply connects to 264V/50Hz AC input voltage.

1.10 Printed circuit board

- Technology Single sided FR2
- Dimensions 134mm(L), 88mm(W) and 40mm(H)

1.11 EMI

Meet international standards

2 Adaptor Module Information

2.1 Schematic

PFC Part:

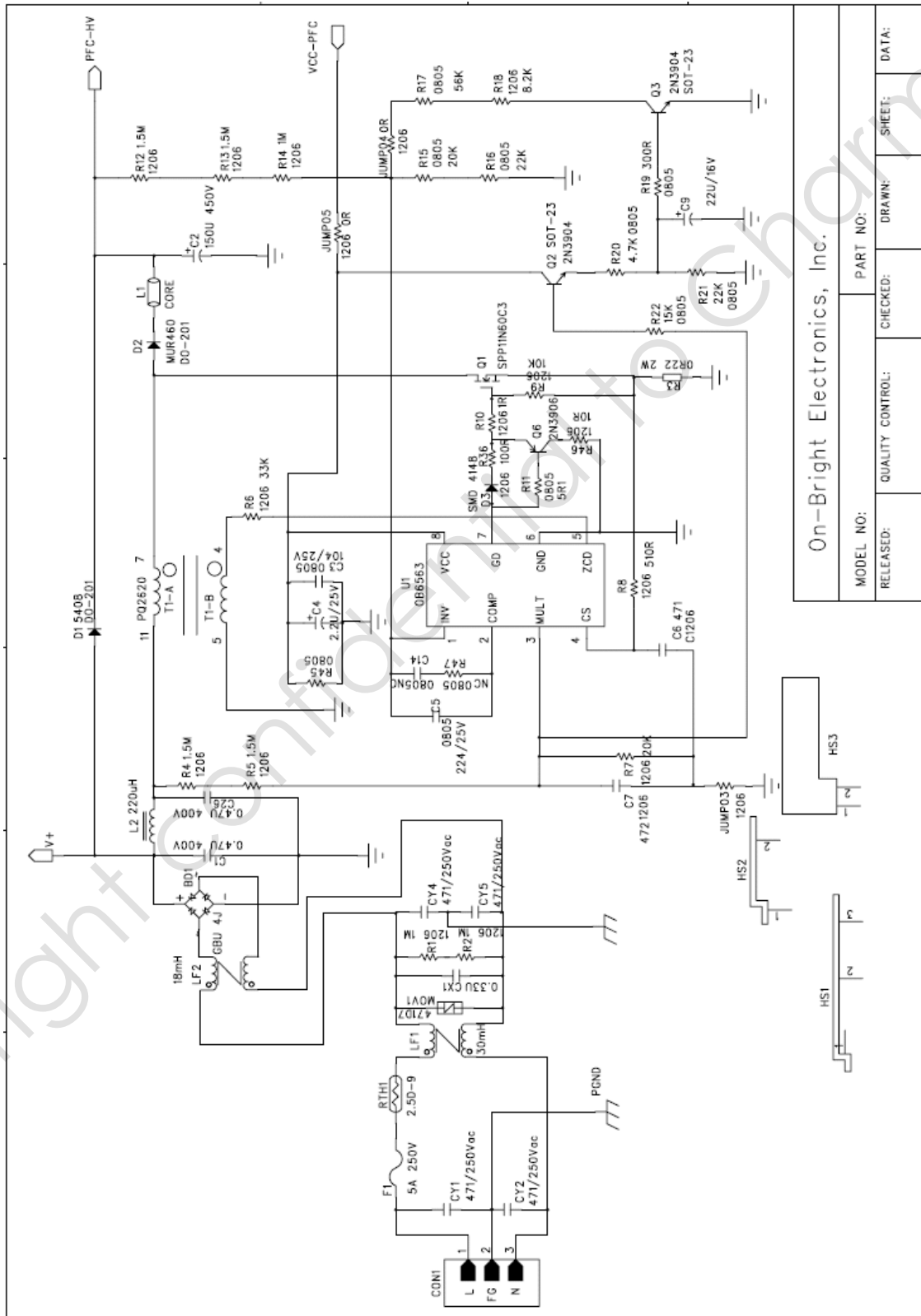

2.2 PCB Gerber File

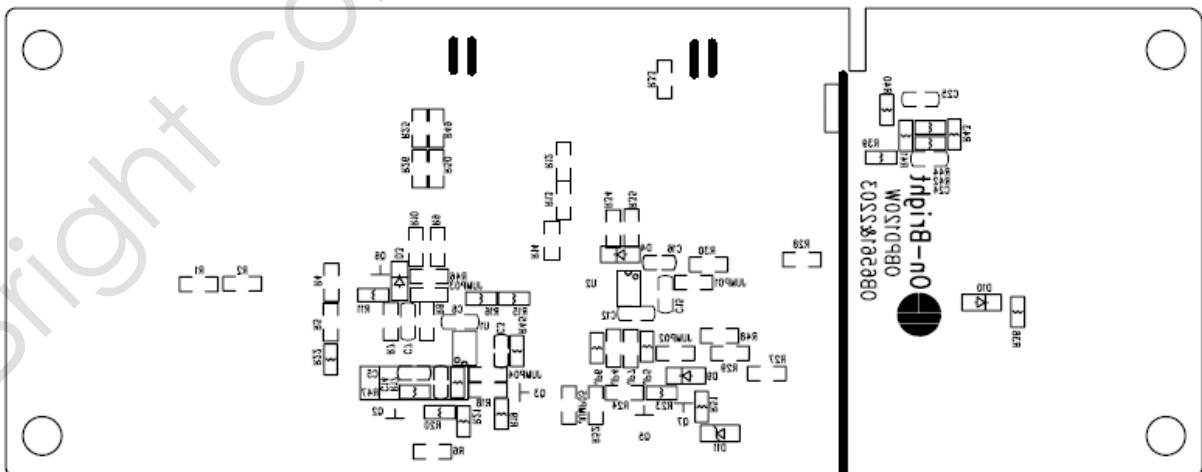
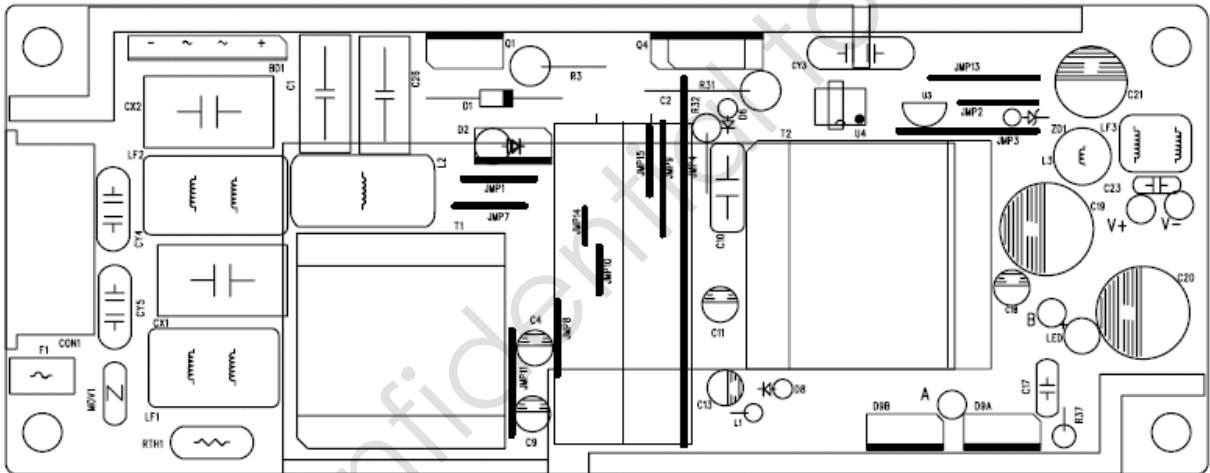
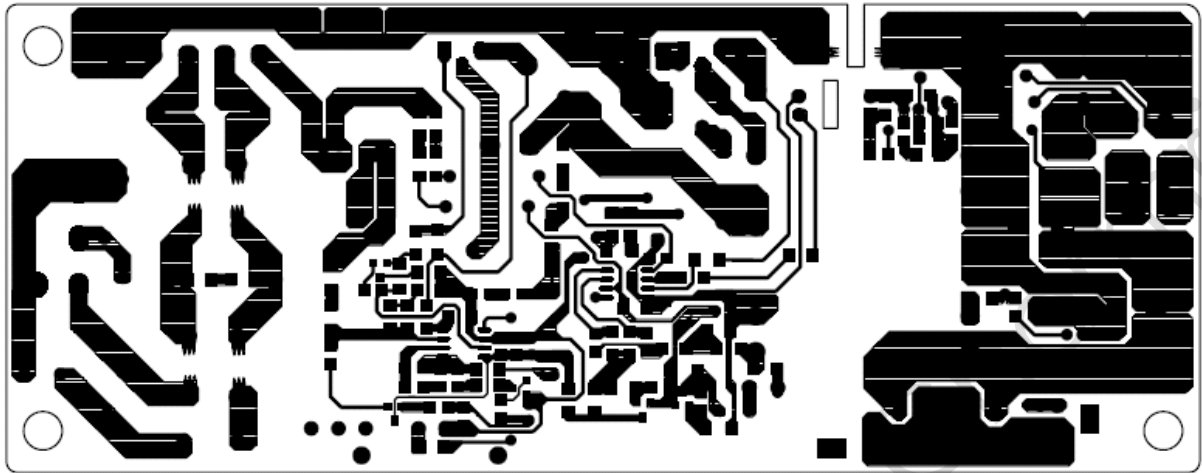

2.3 Bill of material

Position	Description	QTY
BD1	Diode, bridge recovery, GBU4J, 4A/ 600V	1
C1.C26	Capacitor, metal poly, 0.47U/400V, -40/85°C, ±20%	2
C2	Capacitor, aluminum electrolytic, 150uF/450V, -40/85°C, ±20%, Φ18*45mm	1
C3	Capacitor, ceramic,100nF/25V, X7R, ±10%, SMD0805	1
C4.	Capacitor, aluminum electrolytic, 2.2uF/25V, -40/85°C, ±20%	1
C5	Capacitor, ceramic,220nF/25V, X7R, ±10%, SMD0805	1
C6	Capacitor, ceramic,470PF/25V, X7R, ±10%, SMD1206	1
C7	Capacitor, ceramic,4.7nF/25V, X7R, ±10%, SMD1206	1
C8	Capacitor, ceramic,220PF/25V, X7R, ±10%, SMD0805	1
C9.C13	Capacitor, aluminum electrolytic, 22uF/50V, -40/85°C, ±20%	2
C10	Capacitor, metal poly, 10nF/630V, -40/85°C, ±20%	1
C11.C18	Capacitor, aluminum electrolytic, 4.7uF/50V, -40/85°C, ±20%	2
C12.C24	Capacitor, ceramic,100nF/25V, X7R, ±10%, SMD1206	2
C15.C25	Capacitor, ceramic,100PF/25V, X7R, ±10%, SMD1206	2
C16	Capacitor, ceramic,18nF/25V, X7R, ±10%, SMD0805	1
C17	Capacitor, film,1nF/50V, -40/85°C, ±10%,	1
C19.C20	Capacitor, aluminum electrolytic, 1000uF/25V, -40/85°C, ±20%,Φ12.5*20mm	2
C21	Capacitor, aluminum electrolytic, 470uF/25V, -40/85°C, ±20%,Φ10*16mm	1
C23	Capacitor, film,100nF/50V, -40/85°C, ±10%,	1
CON1	Connect,AC SOCKET,2.5A/250Vac,3PIN	1
CX1	Capacitor,X2, 0.33uF/275VAC, -40/85°C, ±20%	1
CY1.CY2. CY4.CY5	Capacitor,Y2,disc,470PF/250VAC, -40/85°C, ±20%	4
CY3	Capacitor,Y2,disc,2.2nF/250VAC, -40/85°C, ±20%	1
D1	Diode,recovery, 1N5408,3A/1000V,DO-201	1
D2	Diode,ultra fast recovery,MUR460, 4A/600V, DO-201	1
D3.D4.D9.D10	Diode ,fast recovery, 1N4148, 0.1A /100V,SMD1206H	4
D6	Diode ,fast recovery, FR107, 1A/1000V,DO-401	1
D8	Diode ,fast recovery, FR104, 1A/600V,DO-401	1
D9A.D9B	Diode,dual schottky, STPS20H100CT, 2*10A/100V,TO220	2
F1	Fuse, 5A/250V, Φ4*10mm	1
JP6	Resistor,chip, 0R ,1/4W,±5%,SMD0805	1
JP7	Resistor,chip, 0R ,1/2W,±5%,SMD1206	1
JUMP01.02.03.04.05	Resistor,chip, 0R ,1/2W,±5%,SMD1206	4
L1	Core,for D2,1.5*3.5*8mm	
L2	Inductor, choke,220uH min, core9*18*6.5mm	1
L3	Inductor,power choke,4.7uH,±10%,core, Φ5*20mm	1
L4	Core,for D8,1.5*3.5*8mm	
LED	LED, Φ5mm	1
LF1	Inductor, choke,dual winding,13mH min, core8.5*14*7mm	1
LF2	Inductor, choke,dual winding,18mH min, core13.5*22*8.5mm	1
LF3	Inductor, choke,dual winding,30uH,±10%, core5*9.5*5mm	1

MOV1	Varistor ,disk, 7D471,300Vac rms max,385Vdc rms max, 600Amax,Φ7mm	1
Q1	MOSFET,cool MOS power N-channel, SPP11N60C3, 11A/650V,0.38R,TO220	1
Q2.Q3	Transistor, NPN,2N3904,0.2A/40V,SMD,SOT23	2
Q4	MOSFET, N-channel, SPP8N80C3, 8A/800V, 0.65R,TO220	1
Q6	Transistor, PNP,2N3906,0.2A/40V,SMD,SOT23	1
R1.R2.R14.R26	Resistor,chip, 1M ,1/2W, ±5%,SMD1206	4
R3	Resistor,metal film,axial,RN55,0R22, 2W, ±5%	1
R4.R5.R12.R13.R25	Resistor,chip, 1.5M ,1/2W, ±5%,SMD1206	5
R6	Resistor,chip, 33K ,1/2W, ±5%,SMD1206	1
R7	Resistor,chip, 20K ,1/2W, ±5%,SMD1206	1
R8.R30.R39	Resistor,chip, 510R ,1/2W, ±5%,SMD1206	3
R9.R33	Resistor,chip, 10K ,1/2W, ±5%,SMD1206	2
R10.R27	Resistor,chip, 1R ,1/2W, ±5%,SMD1206	2
R11	Resistor,chip, 5R1 ,1/4W, ±5%,SMD0805	1
R15.R22	Resistor,chip, 20K ,1/4W, ±5%,SMD0805	2
R16	Resistor,chip, 22K,1/4W, ±5%,SMD0805	1
R17	Resistor,chip, 56K,1/4W, ±5%,SMD0805	1
R18	Resistor,chip, 8.2K,1/4W, ±5%,SMD0805	1
R19	Resistor,chip, 300R,1/4W, ±5%,SMD0805	1
R20.R41	Resistor,chip, 4.7K,1/4W, ±5%,SMD0805	2
R21	Resistor,chip, 15K,1/4W, ±5%,SMD0805	1
R28	Resistor,chip, 22R,1/2W, ±5%,SMD1206	1
R29	Resistor,chip, 120K,1/2W, ±5%,SMD1206	1
R31	Resistor,metal film,axial,RN55,0R13, 2W, ±5%	1
R32	Resistor,metal film,axial, 100K, 1W, ±5%	1
R34.R36	Resistor,chip, 47R,1/2W, ±5%,SMD1206	2
R35.R46	Resistor,chip,10R,1/2W, ±5%,SMD1206	2
R37.R49	Resistor,metal film,axial,22R, 1W, ±5%	2
R38	Resistor,chip, 10K,1/4W, ±5%,SMD0805	1
R40	Resistor,chip, 2K,1/4W, ±5%,SMD0805	1
R42	Resistor,chip, 240K,1/4W, ±1%,SMD0805	1
R43	Resistor,chip, 33K,1/4W, ±1%,SMD0805	1
R44	Resistor,chip, 4.99K,1/4W, ±1%,SMD0805	1
R52	Resistor,chip, 3.3R,1/2W, ±5%,SMD1206	1
R48	Resistor,chip, 30K,1/2W, ±5%,SMD1206	1
RTH1	NTC thermistor,disk, 2.5R-9,2.5R,8Arms, Φ9mm	1
T1	Xfmr,boost inductor,400uH,10KHz/1V,PQ2620	1
T2	Transformer, 300uH,10KHz/1V,PQ3220	1
U1	IC, PFC controller,OB6563,SO-8	1
U2	IC,QR controller, OB2203, SO-8	1
U3	IC,Precision Adjustable Shunt Regulator ,TL431, TO-92	1
U4	IC,Photocoupler ,PC817B, DIP4	1
ZD1	Diode,zener, 24V, 1W,DO401	1
PCB	OBPD120W,65*167mm	1

2.4 Transformer Design

2.4.1 Transformer Specification

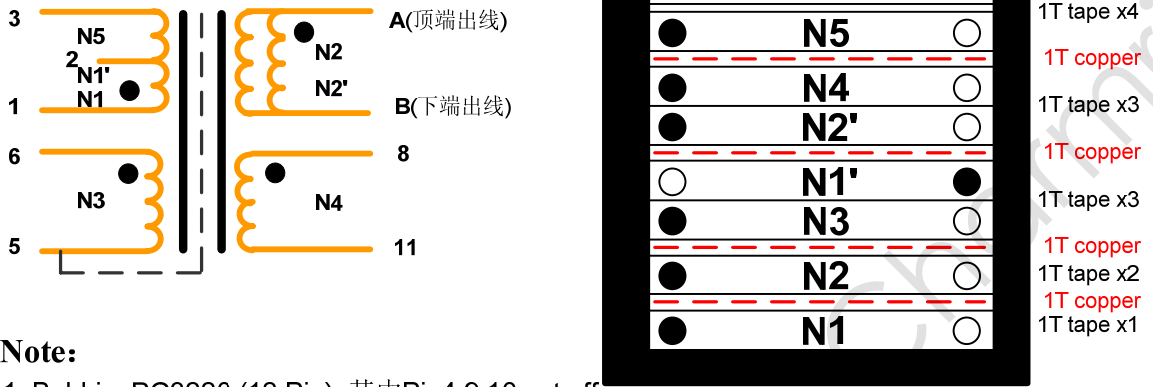

Note:

1. Bobbin: PG3220 (12 Pin) ;其中Pin4,9.10 cut off
2. Core 材质: TDK PC 44.
3. L1-3=300u H +/- 5%. (at: 10 K Hz, 0.3 V)
4. HI-POT: (60 Hz/5 m A/2 SET)
Pri to Sec 3750 Vac; Pri to core 1800Vac

2.4.2 Transformer Winding data

c	Winging	Material	Start	Turns	Finish
1	N1	Φ0.45*2 2UEW	1	9	不断线 →
2	TAPE	TAPE W=10mm (Y)		1.3	
3	Copper	Copper W=9mm P=0.02mm		1.1	5
4	TAPE	TAPE W=10mm (Y)		1.3	
5	N2	Φ0.60*2 三层绝缘线	A	5	B
6	TAPE	TAPE W=10mm (Y)		1.3	
7	Copper	Copper W=9mm P=0.02mm		1.1	5
8	TAPE	TAPE W=10mm (Y)		1.3	
9	N3	Φ0.12*3 2UEW 间绕	6	4	5
10	TAPE	TAPE W=10mm (Y)		1.3	
11	N1'	Φ0.45*2 2UEW	→ 不断线	9	2
12	TAPE	TAPE W=10mm (Y)		1.3	
13	Copper	Copper W=9mm P=0.02mm		1.1	5
14	TAPE	TAPE W=10mm (Y)		1.3	
15	N2'	Φ0.60*2 三层绝缘线	A	5	B
16	N4	Φ0.20*1 三层绝缘线 间绕到 N2	8	2	11
17	TAPE	TAPE W=10mm (Y)		1.3	
18	Copper	Copper W=9mm P=0.02mm		1.1	5

19	TAPE	TAPE W=10mm (Y)		1.3	
20	N5	$\Phi 0.45*2$ 2UEW	2	9	3
21	TAPE	TAPE W=10mm (Y)		3	

2.4.3 Boost inductor Specification

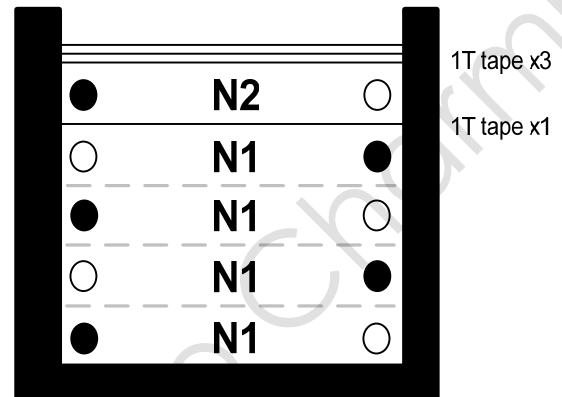
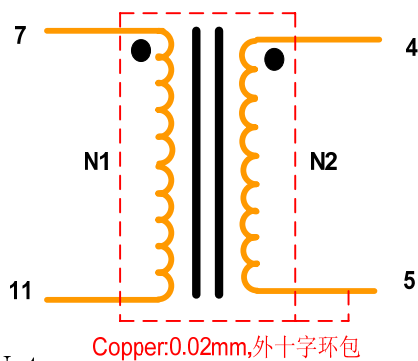

Note:

1. Bobbin: PG2620 (12 Pin) ;其中Pin6,8,9,10,12 cut off
2. Core 材质: TDK PC 44.
3. L7-11=400u H +/- 5%. (at: 10 K Hz, 0.3 V)
4. HI-POT: (60 Hz/5 m A/2 SET)
Pri to Sec 3750 Vac; Pri to core 1500Vac

2.4.4 Boost inductor Winding data

c	Winging	Material	Start	Turns	Finish
1	N1	$\Phi 0.20*10$ 利兹线	7	52	11
2	TAPE	TAPE W=10mm (Y)		1.3	
3	N2	$\Phi 0.20*1$ 2UEW	4	7	5
4	TAPE	TAPE W=10mm (Y)		3	

2.5 Adaptor Module Snapshot

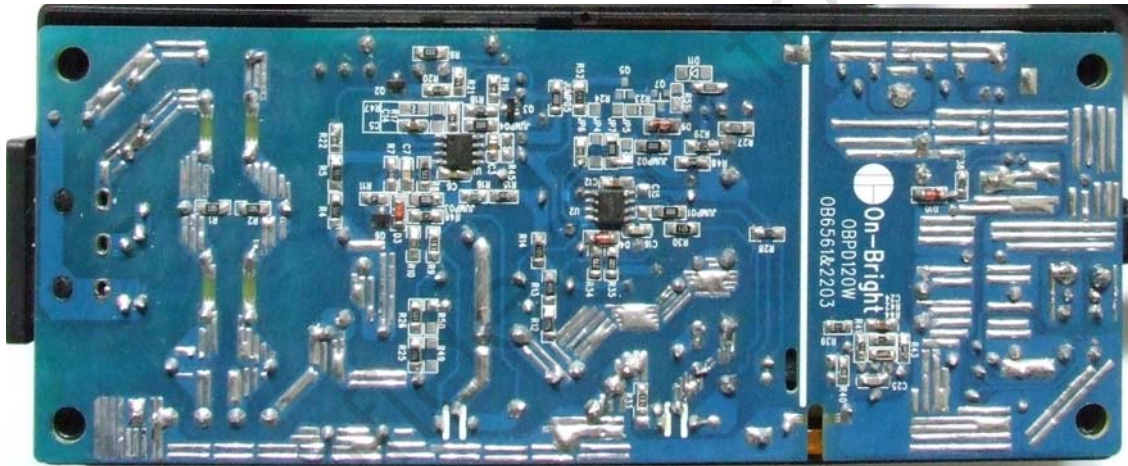
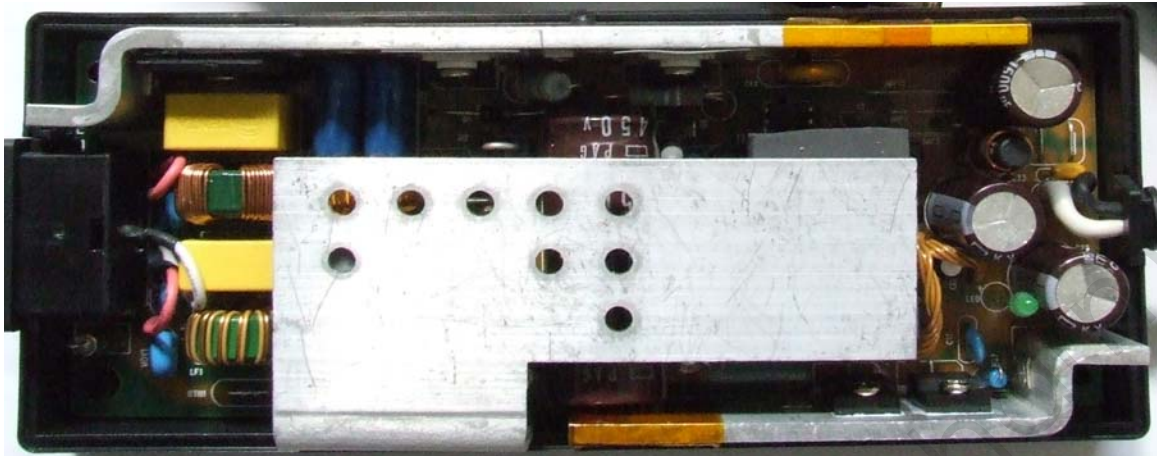

3 Performance Evaluation

This session presents the test results of OBPD120W-H240A module up to date. Results on inrush current and safety test are not included and will be added when they become available.

Overall, the module meets design specifications.

Performance Highlights

- The standby power is about 0.29W under 240Vac/50HZ no load.
- The efficiency more than 87.7% under normal line with full load.
- ESD passed 15kV air discharge and 8kV contact discharge test.
- EMI passed EN55022 and FCC15 Class B test with more than 6dB margin

Characterization Results Summary

Test Item	Test result
1. Input characteristics	
Input current (90V/60Hz, full load)	1.56A Max
Standby power at no load with LED (240Vac, With PFC)	0.29W
Efficiency (110Vac, full load for PCB end)	87.7%
2. Output characteristics	
Line regulation	0.20%
Load regulation	0.26%
Ripple & noise	40mV
Over shoot	2.5% Max
Under shoot	2.1% Max
Dynamic test	308mV
3. Time sequence (90Vac with Full load)	
Turn on delay time	1573mS
Hold up time	89mS
Rise time	26mS
Fall time	15mS
4. Protections	
Over voltage protection	23V
Over current protection (90Vac ~264Vac)	7.3A ~8.1A
Short Circuit protection	OK

Test Equipments

- | | | |
|------------------------|----------|---------|
| ■ AC Source: | WEST | WEW1010 |
| ■ Digital Power Meter: | YOKOGAWA | WT210 |
| ■ Electrical Load: | Prodigit | 3315C |
| ■ Oscilloscope: | LeCroy | WS424 |
| ■ Multimeter | VICTORY | VC9807A |

3.1 Input Characteristics

3.1.1 Input Normal Characteristics

100% load					
Test Items	Test data				
Vin(Vac)	90	132	180	220	264
Frequency (Hz)	63	57	53	50	47
Iin(A)	1.56	1.07	0.75	0.62	0.54
PF	0.999	0.997	0.994	0.986	0.971
THD (%)	6.1	4.7	6.8	7.2	9.7

50% load					
Test Items	Test data				
Vin(Vac)	90	132	180	220	264
Frequency(Hz)	63	57	53	50	47
Iin (A)	0.75	0.52	0.40	0.38	0.30
PF	0.998	0.992	0.978	0.853	0.822
THD(%)	5.9	7.2	8.3	9.0	16.3

Character Curve

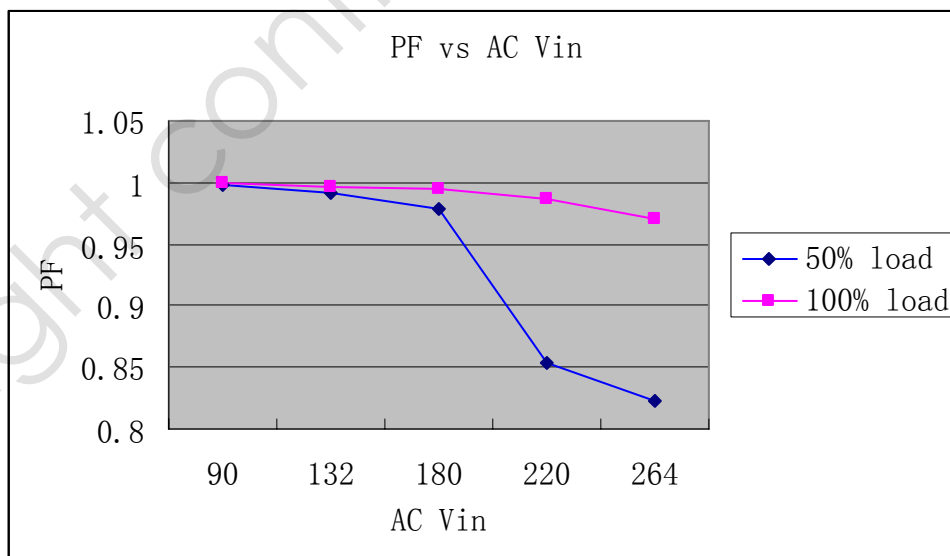

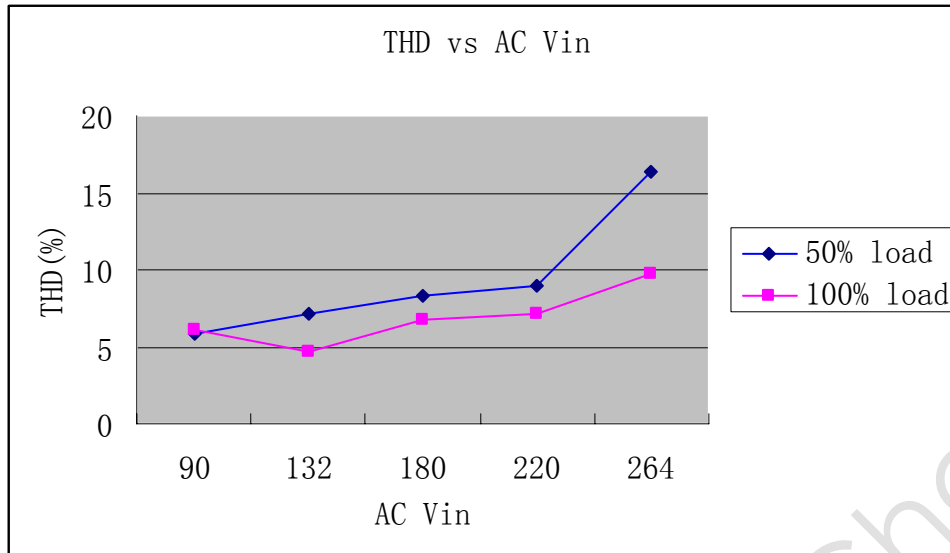

3.1.2 Input current and Standby power

The module was tested at different input voltages (from 90Vac to 264Vac)

Table 1 Input current at full load

Input Voltage	90V/60Hz	110V/60Hz	132V/60Hz	180V/50Hz	220V/50Hz	264V/50Hz
Input Current(A)	1.56	1.25	1.07	0.75	0.62	0.54

Table 2 Standby power at no load with LED (with PFC)

Input Voltage	90V/60Hz	110V/60Hz	132V/60Hz	180V/50Hz	220V/50Hz	264V/50Hz
Pin (W)	0.116	0.127	0.147	0.191	0.256	0.310

3.1.3 Efficiency

Note: All data was measurement at PCB end.

Table 3 Efficiency with PFC part

Vin	Efficiency (%)				Average Eff (%)
	25% Load	50% Load	75% Load	100% Load	
90V/60Hz	85.54	88.54	87.63	86.23	86.98
110V/60Hz	85.85	89.20	88.63	87.73	87.85
132V/60Hz	85.76	89.51	89.20	88.51	88.24
180V/50Hz	85.67	88.19	88.90	89.03	87.94
220V/50Hz	85.75	88.19	89.11	89.30	88.08
264V/50Hz	85.69	88.36	89.07	89.45	88.14
Average Eff (%)	85.71	88.66	88.75	88.37	

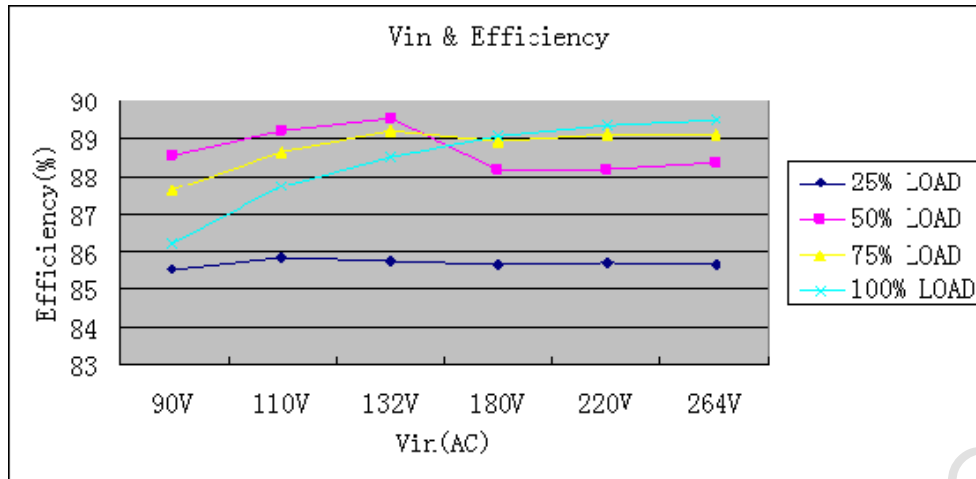

3.2 Output Characteristics

3.2.1 Line Regulation & Load Regulation

Table 4 Line Regulation & Load Regulation

Input Voltage	Output Voltage (V)			Load Regulation (%)
	No Load	Half Load	Full Load	
90V/47Hz	19.20	19.17	19.17	0.15
110V/60Hz	19.20	19.17	19.17	0.15
132V/63Hz	19.20	19.16	19.17	0.2
180V/47Hz	19.20	19.15	19.16	0.26
240V/50Hz	19.20	19.15	19.16	0.26
264V/63Hz	19.20	19.15	19.16	0.26
Line Regulation (%)	0	0.1	0.05	

Note: All data was measured at PCB end.

3.2.2 Ripple & Noise

Table 5 Ripple & Noise measure results

Input Voltage	R&N (mV)		Waveform
	No Load	Full Load	
90Vac/60HZ	15.6mv	38.1mv	
132Vac/60HZ	14.4mv	38.8mv	
180Vac/50HZ	14.4mv	39.4mv	
264Vac/50HZ	16.3mv	39.4mv	

Note: Ripple & noise were measured at DC cord end with a 0.1uF/100V ceramic cap connected in parallel with a 10uF/50V Electrolytic cap. Bandwidth was limited to 20MHZ.

R&N Waveform

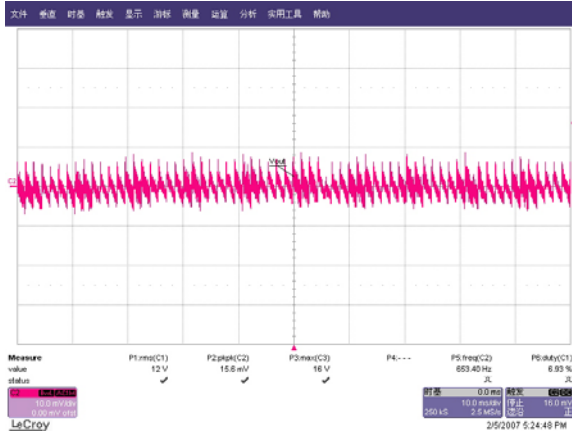

R&N waveform@90Vac input with no load

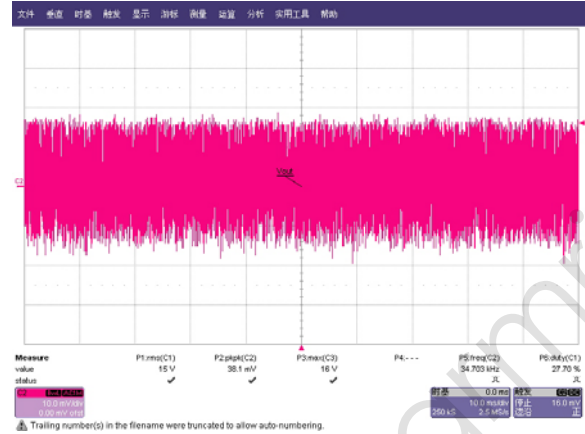

R&N waveform@90Vac input with full load

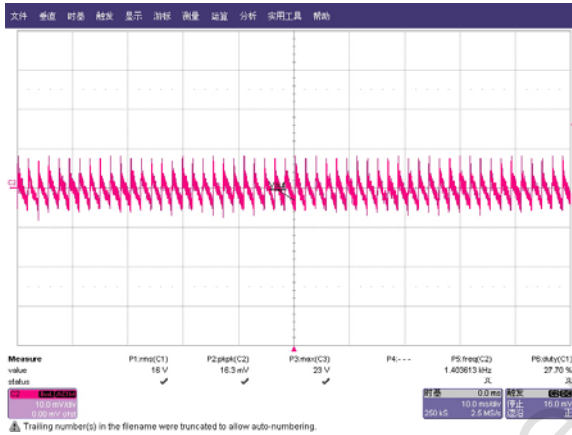

R&N waveform@264Vac input with no load

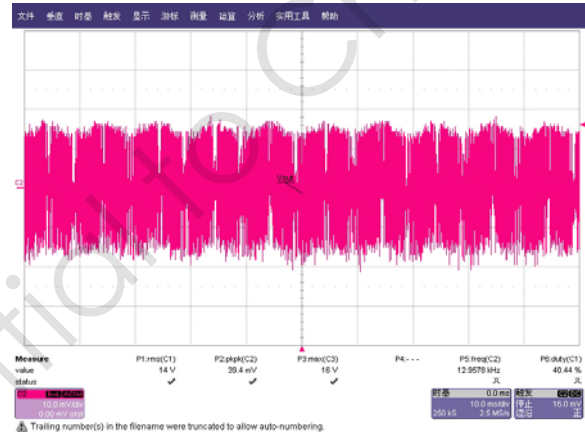

R&N waveform@264Vac input with full load

3.2.3 Overshoot & Undershoot

Ac input switches ON for overshoot and OFF for undershoot

Table 6 Overshoot/undershoot measurement results

Input Voltage	Load	Item	Meas. Data (%)	Waveform
90V/60Hz	Full load	overshoot	2.5	
		undershoot		
	No load	overshoot	0.736	
		undershoot		
264V/50Hz	Full load	overshoot	1.8	
		undershoot	2.1	
	No load	overshoot	1.3	
		undershoot		

Overshoot and undershoot waveform

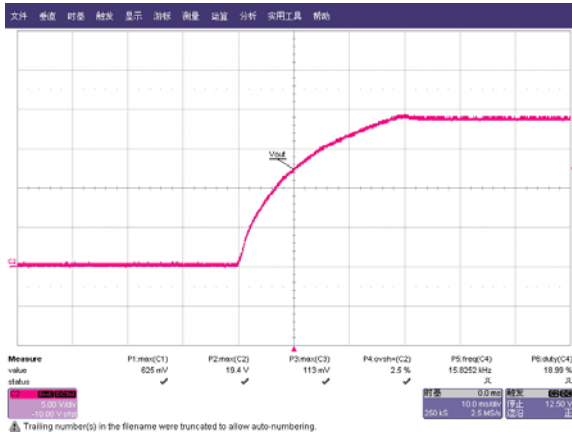

Overshoot waveform @90Vac input with full load

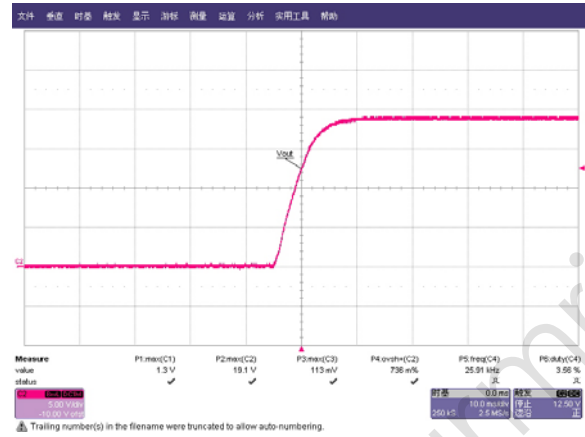

Overshoot waveform @90Vac input with no load

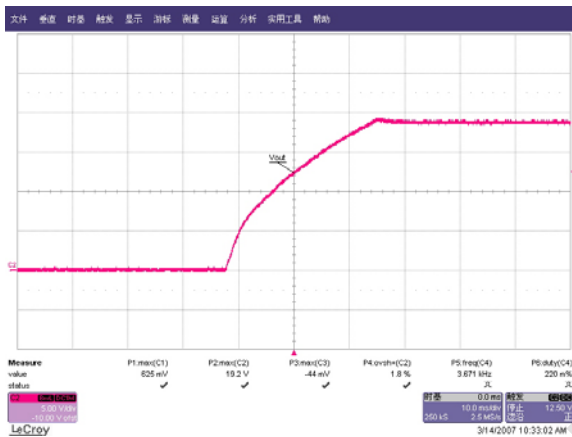

Overshoot waveform @264Vac input with full load

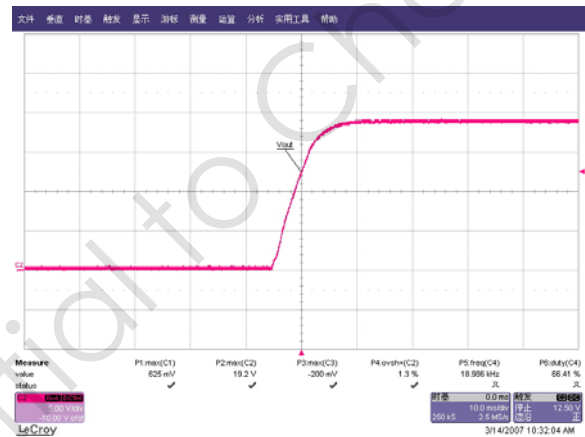

Overshoot waveform @264Vac input with no load

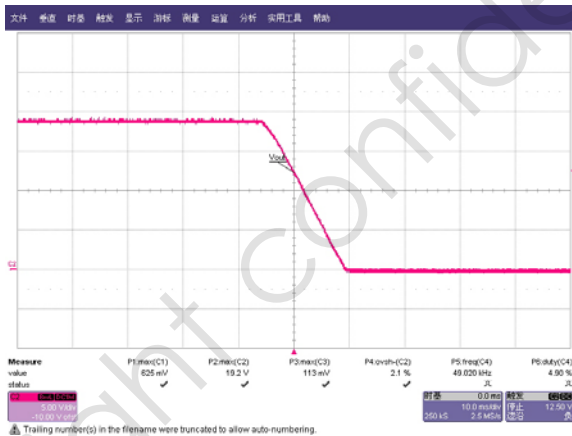

Undershoot waveform @264Vac input with full load

3.2.4 Dynamic Test

A dynamic loading with low set at 1.26 A lasting for 10mS and high set at 5.0A lasting for 50mS is added to output. The ramp is set at 0.125A/uS at transient.

All data was measurement at PCB end.

Table 7 Output voltage under dynamic test

Input voltage	Output voltage (mV)	Waveform
90V/60HZ	308	
132V/60HZ	308	
180V/50HZ	306	
264V/50HZ	308	

Dynamic waveform

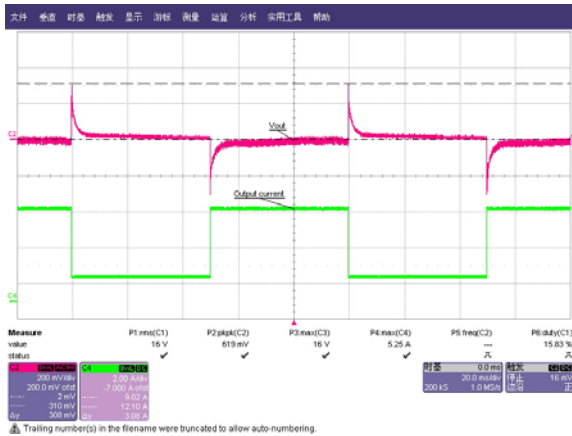

Dynamic waveform @90Vac input

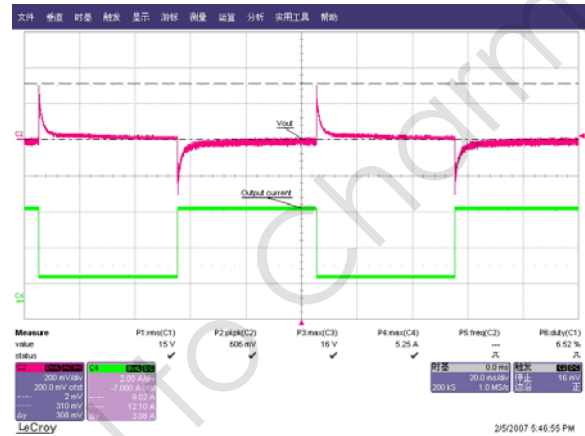

Dynamic waveform @132Vac input

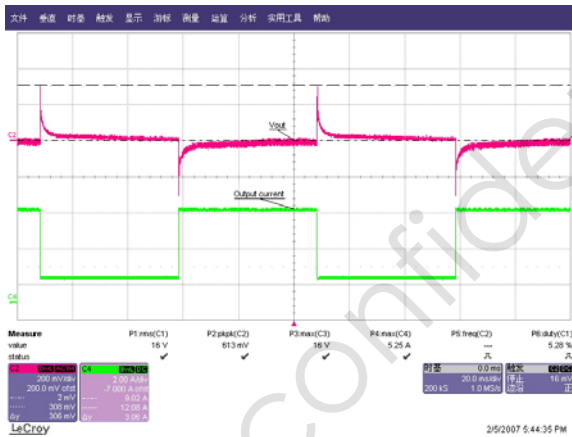

Dynamic waveform @180Vac input

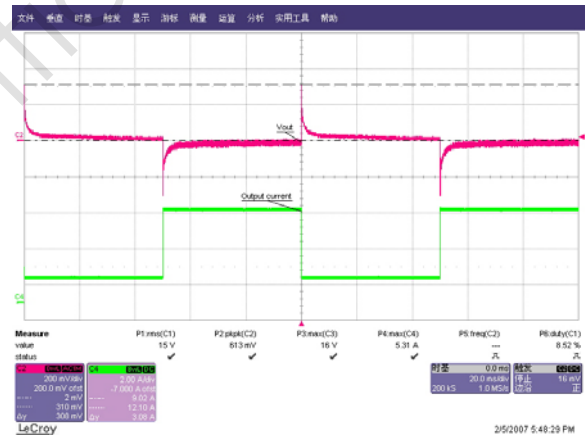

Dynamic waveform @264Vac input

3.2.5 Time Sequence

Load condition: Full load

Table 8 Turn-on delay /hold-up/Rise time/Fall time measurement results

Item	Input voltage	Meas. Data (mS)	Remark
Turn-on delay time	90V/60Hz	1573	
	264V/50Hz	498	
Hold-up time	90V/60Hz	29.5	
	264V/50Hz	89.4	

Rise Time	90V/60Hz	28.4	
	264V/50Hz	26.5	
Fall Time	90V/60Hz	15	
	264V/50Hz	15	

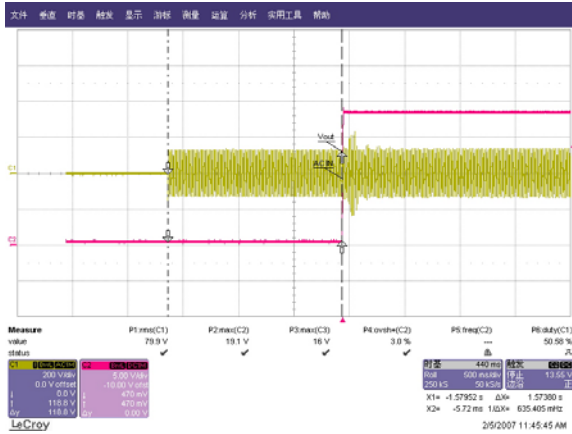
Time sequence waveform

Turn on waveform @90Vac input with full load

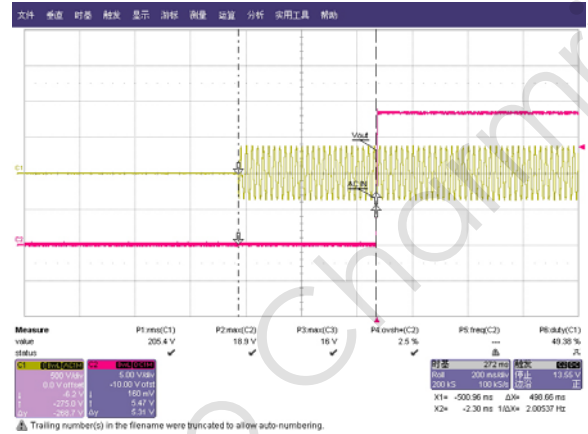

Turn on waveform @264Vac input with full load

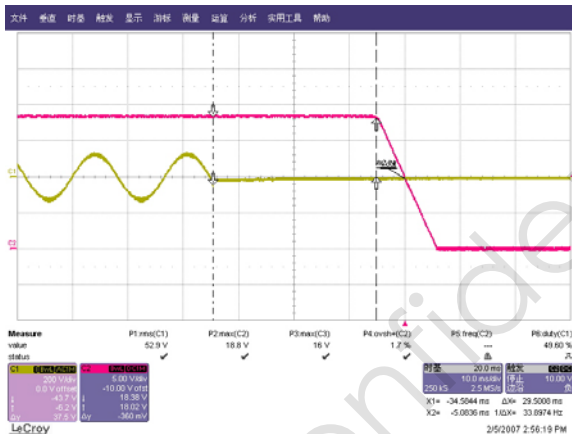

Hold up waveform @90Vac input with full load

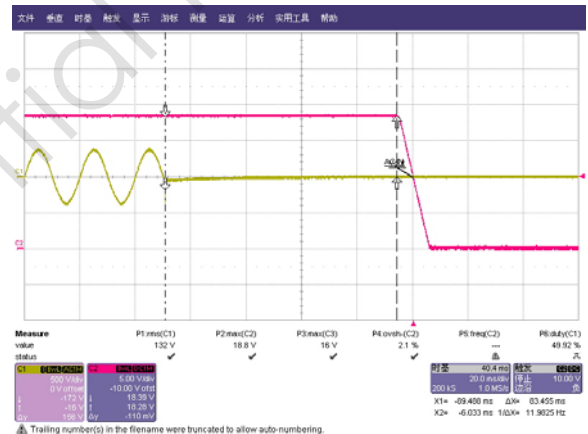

Hold up waveform @264Vac input with full load

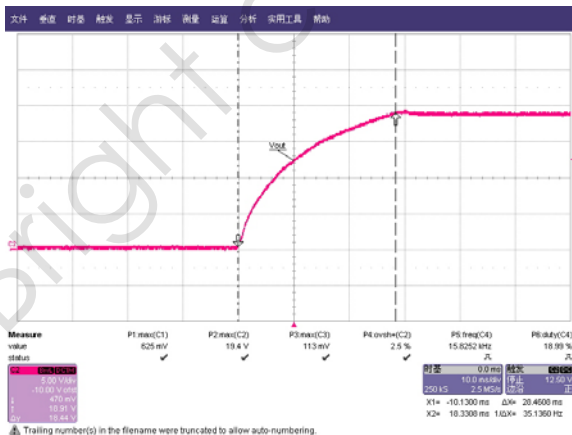

Rise waveform @90Vac input with full load

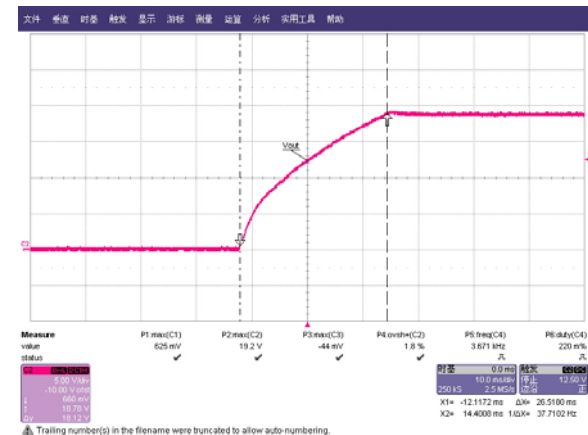

Rise waveform @264Vac input with full load

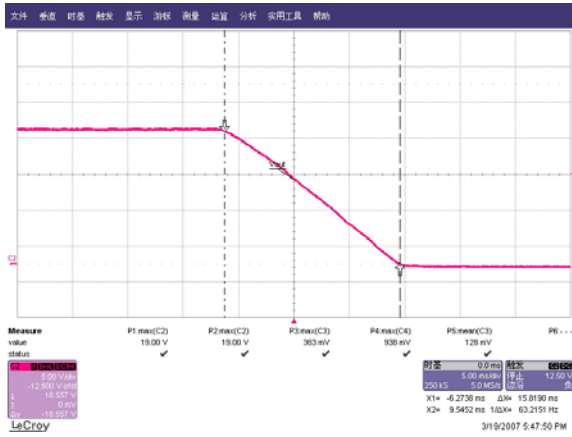

Fall waveform @90Vac with full load

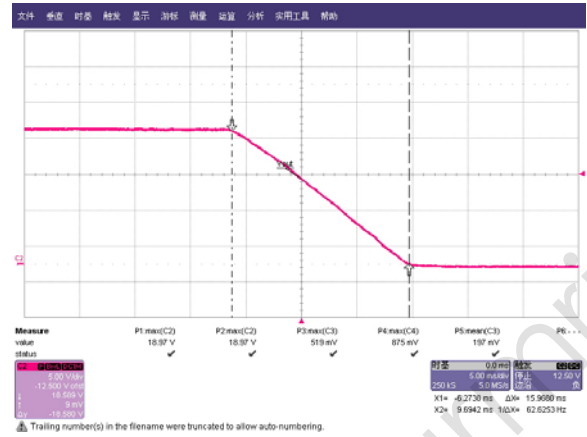

Fall waveform @264Vac with full load

3.3 Protections

3.3.1 Over Current Protection (OCP)

The power supply will shut down when output current exceeds 6.9A~8.8A, and it should recover when the over current condition is removed.

Table 9 OCP value vs. input voltage

Input Voltage	90V/60Hz	120V/60Hz	132V/60Hz	180V/50Hz	240V/50Hz	264V/50Hz
OCP (A)	7.32	7.28	7.48	8.11	8.14	8.11

3.3.2 Over Voltage Protection (OVP)

The power supply will shut down and latch when feedback circuit is disabled, and the output voltage can not be over 26.6V. The unit should recover when the protection condition is removed and restart input.

Table 10 OVP test result

Input Voltage	OVP Trigger Voltage (V)	
	No Load	Full Load
90V/60Hz	22.6	22.5
132V/60Hz	22.8	22.7
180V/50Hz	22.6	22.5
264V/50Hz	23.0	22.9

3.3.3 Short Circuit Protection

Short circuit placed on output will shut down the power supply and the unit should automatic recover after the short circuit condition is removed.

Table 11 SCP test result

Input voltage	90V/60Hz	264V/50Hz
Test Result	OK	OK
Input Power (W)	0.03	0.28

3.4 EMI Test

3.4.1 Conducted EMI Test

EN55022 CLASS B @ full load report

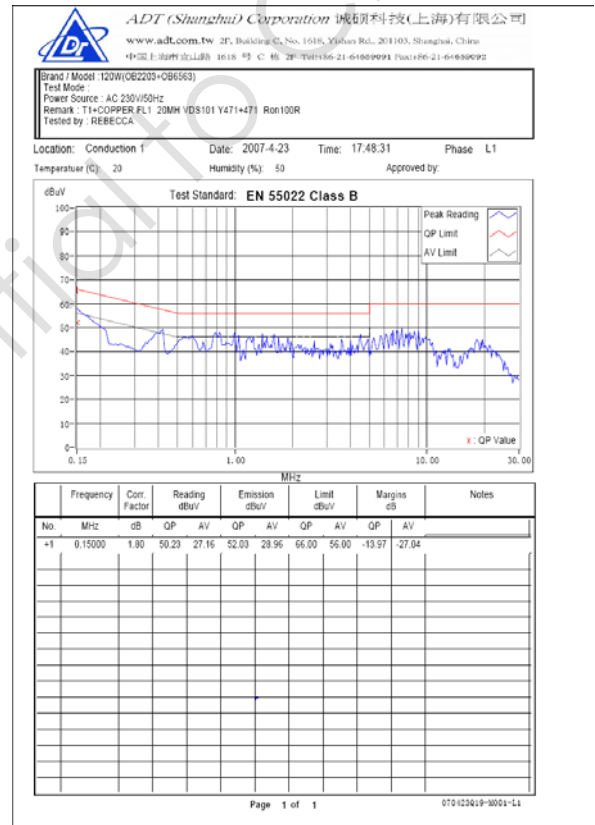
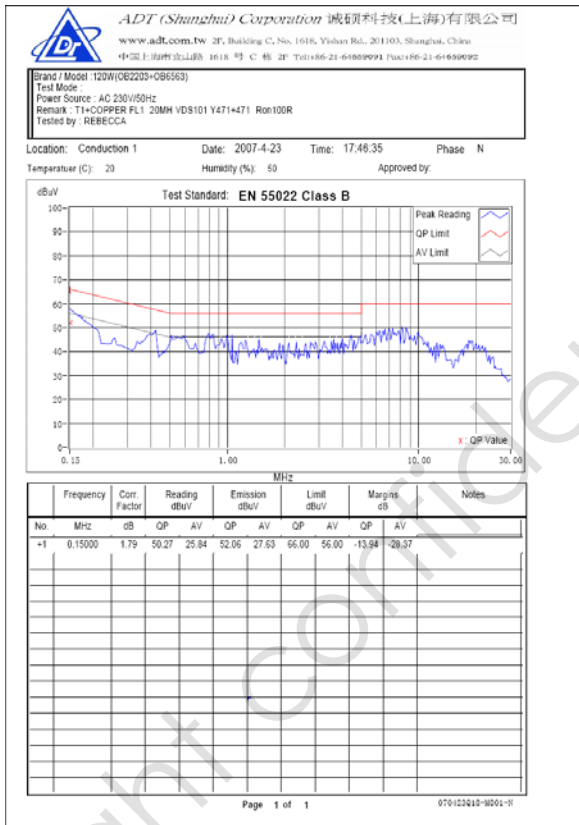

3.4.2 Radiation EMI Test

EN55022 CLASS B @ full load report



ADT (Shanghai) Corporation 诚硕科技(上海)有限公司
 www.adt.com.tw 2/F, Building C, No. 1618, Yishan Rd., 201103, Shanghai, China
 中国上海市宜山路 1618 号 C 栋 2F Tel:+86-21-64659091 Fax:+86-21-64659092

Brand / Model : 120W(OB2203*OB6563)
 Remark: Ron 100R MOUDLE IN COPPER
 Tested by : Brian

Location: ADT-SH 9x6x6 Chamber. Date: 2007-4-23 Time: 9:13 Approved by:
 Temperature (C): 20.0 Humidity (%): 50 Polarity: Horizontal

Level (dBuV/m) CISPR 22-EN55022-CNS13438-VCCI Class B

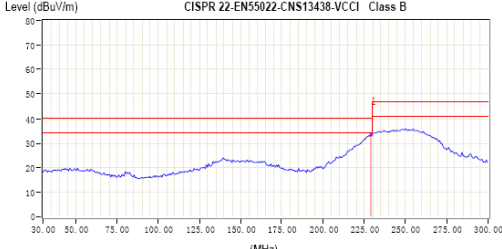

(MHz)

This data is for evaluation purposes only. It cannot be used for EMC approvals unless it contains the approved signature. If you have any questions regarding the test data, you can write your comments to service@mail.adt.com.tw

No.	Frequency MHz	Factor dB	Reading dBuV/m	Emission dBuV/m	Limit dBuV/m	Margin dB	Tower / Table cm deg
* 1	229.12	14.47	19.05	33.52	40.00	-6.48	-- --

Page 1 of 1 D:\ADT_Radiated_V7.5.14_Shanghai\log\2007_04_23.dat



ADT (Shanghai) Corporation 诚硕科技(上海)有限公司
 www.adt.com.tw 2/F, Building C, No. 1618, Yishan Rd., 201103, Shanghai, China
 中国上海市宜山路 1618 号 C 栋 2F Tel:+86-21-64659091 Fax:+86-21-64659092

Brand / Model : 120W(OB2203*OB6563)
 Remark: Ron 100R MOUDLE IN COPPER
 Tested by : Brian

Location: ADT-SH 9x6x6 Chamber. Date: 2007-4-23 Time: 9:13 Approved by:
 Temperature (C): 20.0 Humidity (%): 50 Polarity: Vertical

Level (dBuV/m) CISPR 22-EN55022-CNS13438-VCCI Class B

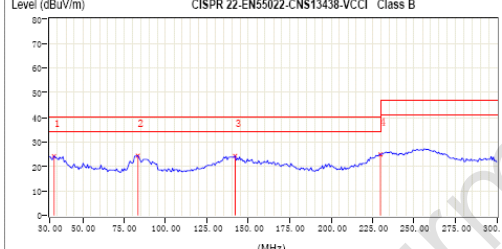

(MHz)

This data is for evaluation purposes only. It cannot be used for EMC approvals unless it contains the approved signature. If you have any questions regarding the test data, you can write your comments to service@mail.adt.com.tw

No.	Frequency MHz	Factor dB	Reading dBuV/m	Emission dBuV/m	Limit dBuV/m	Margin dB	Tower / Table cm deg
1	32.70	15.14	8.96	24.10	40.00	-15.90	-- --
2	83.33	11.63	12.68	24.29	40.00	-15.71	-- --
3	142.05	16.37	7.83	24.20	40.00	-15.80	-- --
* 4	229.80	14.52	10.31	24.82	40.00	-15.18	-- --

Page 1 of 1 D:\ADT_Radiated_V7.5.14_Shanghai\log\2007_04_23.dat

3.5 ESD Test



AMC410-8 Electrostatic Discharge Test Data

Project No.: _____

Immunity	Electrostatic Discharge	<input checked="" type="checkbox"/> IEC 61000-4-2: 2001	
		<input type="checkbox"/> Others: _____	
		<input checked="" type="checkbox"/> PASS / <input type="checkbox"/> FAIL	
*Applicant: <u>ONBRIGHT</u>			
*EUT: <u>POWER SUPPLY</u>			
*M/N: <u>OBPD120W OB6561&2203</u>		*S/N: _____	
Ambient Condition: <u>19</u> °C <u>45</u> %RH			
Atmosphere Pressure: <u>101.3kPa</u>			
*Air Discharge: <input type="checkbox"/> ± 8kV or <input checked="" type="checkbox"/> Other: <u>15KV</u>		Repeating Rate: <u>1s</u>	
*Contact Discharge: <input type="checkbox"/> ± 4kV or <input checked="" type="checkbox"/> Other: <u>10KV</u>		Repeating Rate: <u>1s</u>	
*Operation Mode: <u>FULL LOAD</u>		*Criterion: <u>A</u>	
Location	Points	Kind (A-Air, C-Contact)	Result
Output port	2	C	PASS
Input port	2	A	PASS
Output port	2	A	PASS
/	/	/	/
/	/	/	/
/	/	/	/
/	/	/	/
/	/	/	/
/	/	/	/
Test Description:			
*Test Equipment	ESD Generator	<input checked="" type="checkbox"/> EM Test Dito (S/N: <u>Y0503100054</u>)	Cal: <u>2007.4.25</u>
		<input type="checkbox"/> KeyTek MZ-15/EC (S/N: _____)	Cal: _____
	Other: /	<input type="checkbox"/> _____ (S/N: _____)	Cal: _____
Note: The Items marked with * shall be filled in prior to formal test.			
Test Engineer: <u>kamii</u>		Date: <u>2007.04.12</u>	

Page _____ of _____

3.6 Lighting Test



AMC410-10 Surge Test Data

Project No.: _____

Immunity	Surge	<input checked="" type="checkbox"/> IEC 61000-4-5: 2001 <input checked="" type="checkbox"/> Others: _____ <input checked="" type="checkbox"/> PASS / <input type="checkbox"/> FAIL									
*Applicant: <u>ONBRIGHT</u> *EUT: <u>POWER SUPPLY</u> *M/N: <u>OBPD120W-L190A (OB2203)</u> *S/N: _____											
Ambient Condition: <u>23</u> °C <u>58</u> %RH Atmosphere Pressure: <u>101.3kPa</u>											
*Power supply: <u>230V/50Hz</u> *Repetition: <u>5</u> times per test * Interval: <u>60</u> seconds *Operation Mode: <u>FULL LOAD</u> *Criterion: <u>A</u> *Line: <input checked="" type="checkbox"/> AC Mains / <input type="checkbox"/> DC Supply / <input type="checkbox"/> Signal Line											
*Conductor	*Phase	500V		2kV		4kV		5kV		6kV	
		+	-	+	-	+	-	+	-	+	-
<input checked="" type="checkbox"/> L1 <input checked="" type="checkbox"/> L2 <input type="checkbox"/> PE	0°	/	/	PASS	PASS	/	/	/	/	/	/
	90°	/	/	PASS	PASS	/	/	/	/	/	/
	180°	/	/	PASS	PASS	/	/	/	/	/	/
	270°	/	/	PASS	PASS	/	/	/	/	/	/
<input checked="" type="checkbox"/> L1 <input type="checkbox"/> L2 <input checked="" type="checkbox"/> PE	0°	/	/	/	/	PASS	PASS	/	/	/	/
	90°	/	/	/	/	PASS	PASS	/	/	/	/
	180°	/	/	/	/	PASS	PASS	/	/	/	/
	270°	/	/	/	/	PASS	PASS	/	/	/	/
<input type="checkbox"/> L1 <input checked="" type="checkbox"/> L2 <input checked="" type="checkbox"/> PE	0°	/	/	/	/	PASS	PASS	/	/	/	/
	90°	/	/	/	/	PASS	PASS	/	/	/	/
	180°	/	/	/	/	PASS	PASS	/	/	/	/
	270°	/	/	/	/	PASS	PASS	/	/	/	/
DC Supply		/	/	/	/	/	/	/	/	/	/
Signal Line		L-PE	/	/	/	/	/	/	/	/	/
		L-L	/	/	/	/	/	/	/	/	/
TEST DESCRIPTION:											
*Test Equipment		Surge Generator		<input type="checkbox"/> ECAT (S/N: _____) Cal: _____							
				<input type="checkbox"/> CE Master (S/N: _____) Cal: _____							
				<input checked="" type="checkbox"/> EMC Pro (S/N: <u>0002256</u>) Cal: <u>2006.04.18</u>							
				<input type="checkbox"/> _____ (S/N: _____) Cal: _____							
Note: The Items marked with * shall be filled in prior to formal test.											
Test Engineer: <u>KAMII</u>						Date: <u>2007.04.12</u>					

Page _____ of _____

4 Other important waveform

4.1 Vdd, FB, Sense& Gate wave form at no load/25% load/50% load/full load.

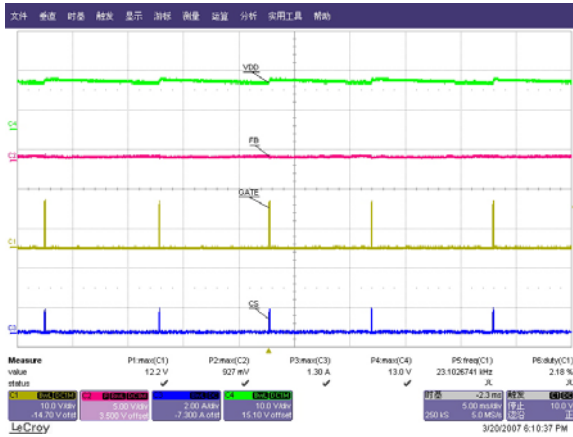

Vdd,FB,Sense&Gate wave form@90Vac; no load

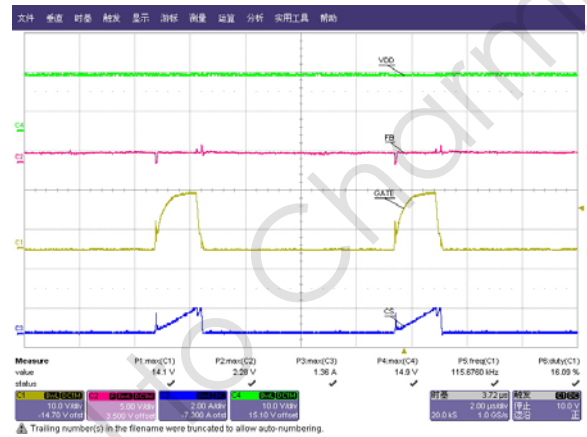

Vdd,FB,Sense&Gate wave form@90Vac; 25% load

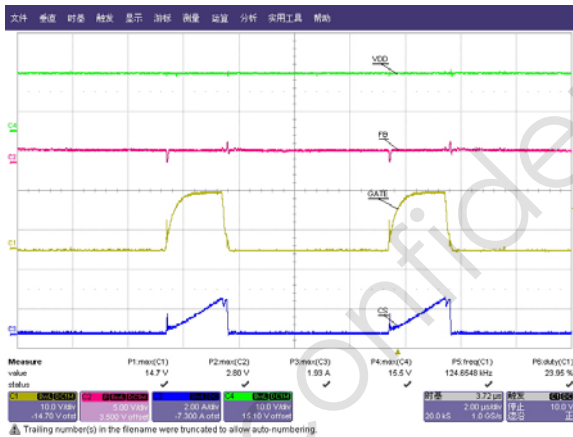

Vdd,FB,Sense&Gate wave form@90Vac; 50% load

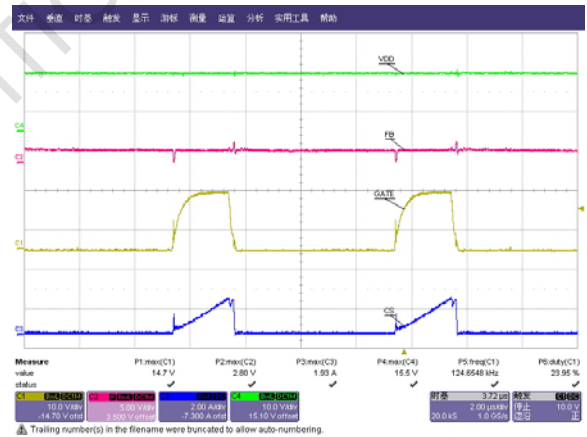

Vdd,FB,Sense&Gate wave form@90Vac; full load

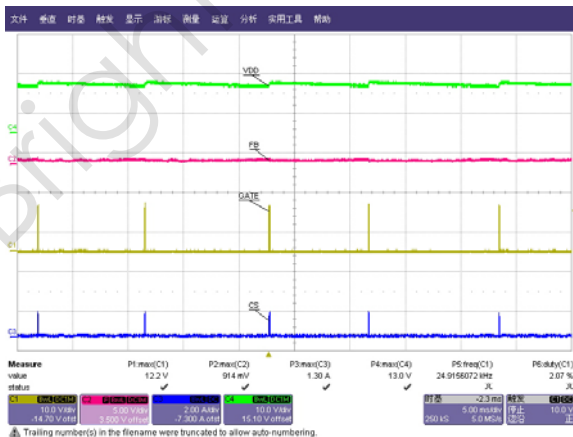

Vdd,FB,Sense&Gate wave form@264Vac; no load

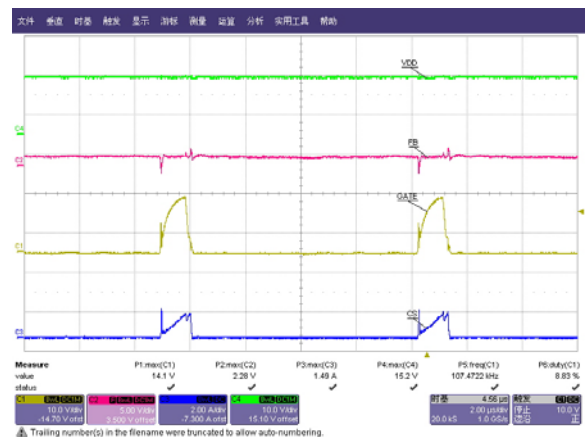

Vdd,FB,Sense&Gate wave form@264Vac; 25% load

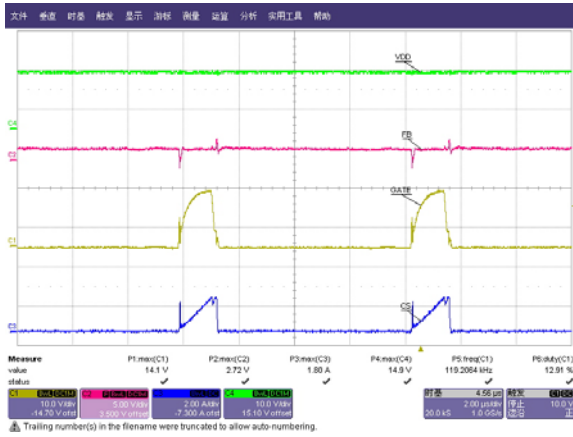

Vdd,FB,Sense&Gate wave form@264Vac; 50% load

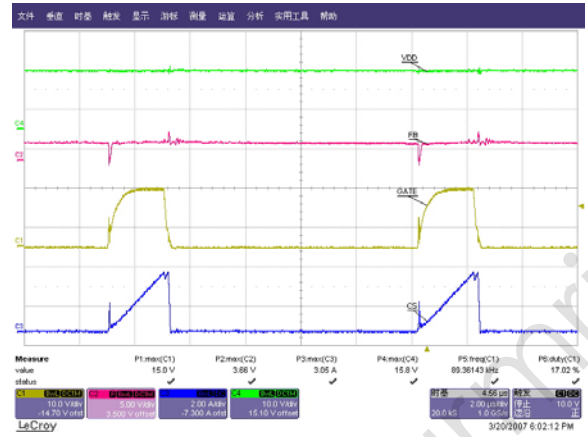

Vdd,FB,Sense&Gate wave form@264Vac; full load

4.2 MOSFET VDS wave, CS wave and Output diode VAK waveform at full load, start/normal/output short

4.2.1 VDS ,CS & VAK start waveform

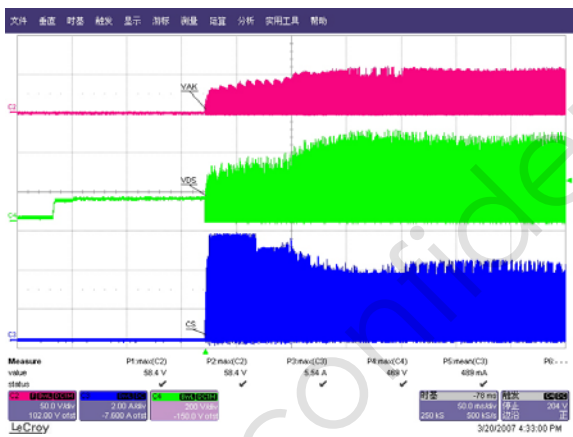

VDS ,CS & VAK start waveform@90Vac; full load

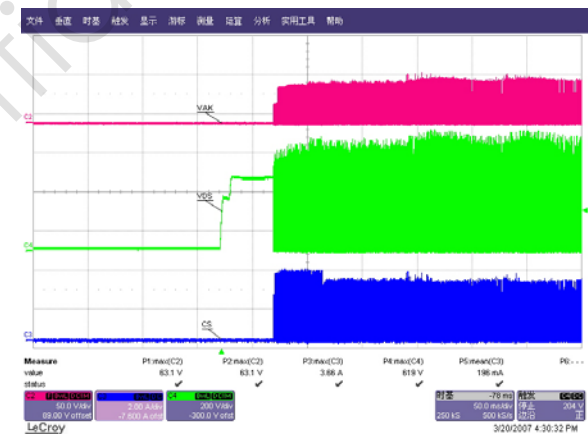

VDS ,CS & VAK start waveform@264Vac; full load

4.2.2 VDS ,CS & VAK normal waveform

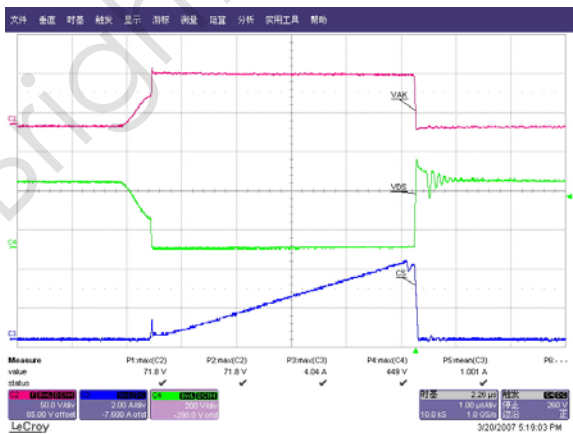

VDS ,CS & VAK normal waveform@90Vac; full load

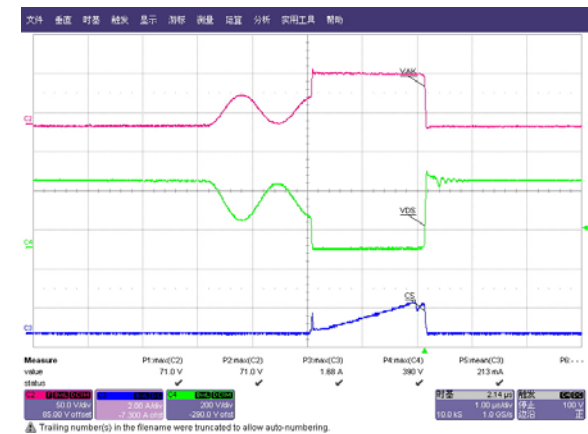

VDS ,CS & VAK normal waveform@90Vac; 2.4A load

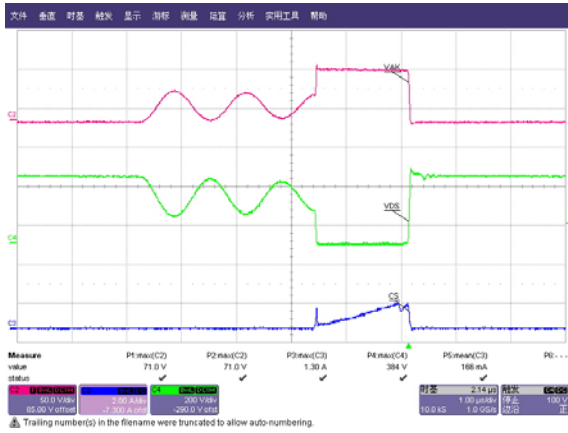

VDS ,CS & VAK normal waveform@90Vac; 1.65A load

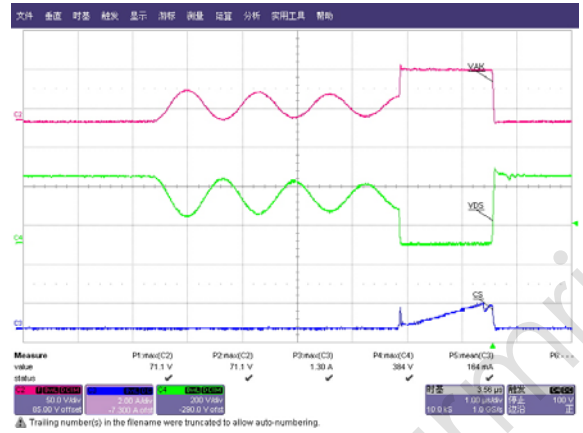

VDS ,CS & VAK normal waveform@90Vac; 1.45A load

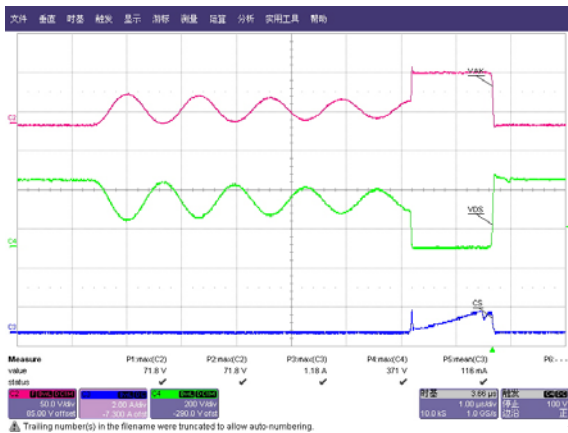

VDS ,CS & VAK normal waveform@90Vac; 1.2A load

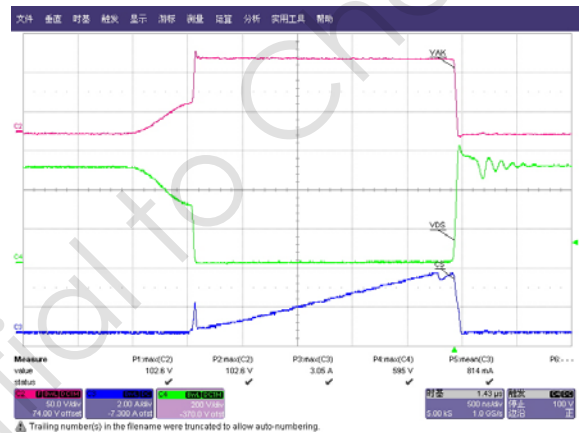

VDS ,CS & VAK normal waveform@264Vac; full load

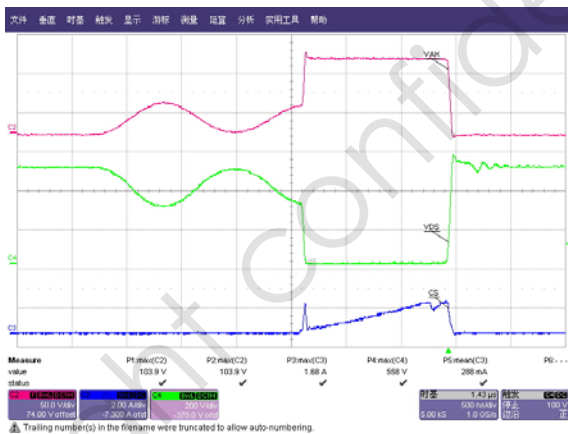

VDS ,CS & VAK normal waveform@264Vac; 3.0A load

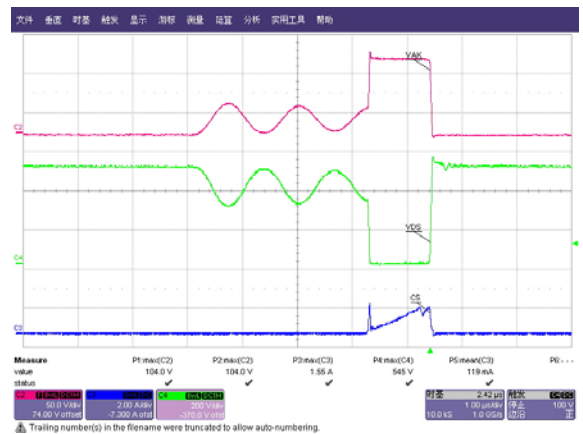

VDS ,CS & VAK normal waveform@264Vac; 2.0A load

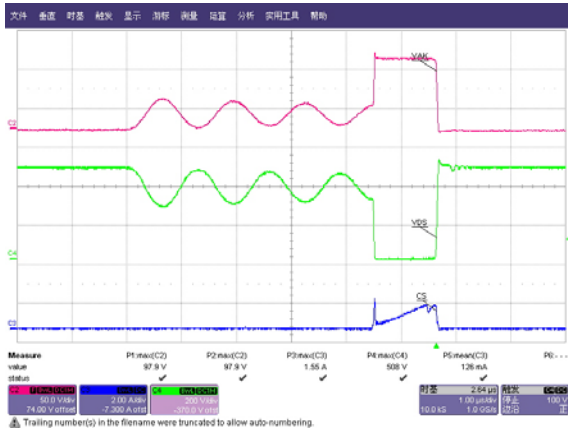

VDS ,CS & VAK normal waveform@264Vac; 1.6A load

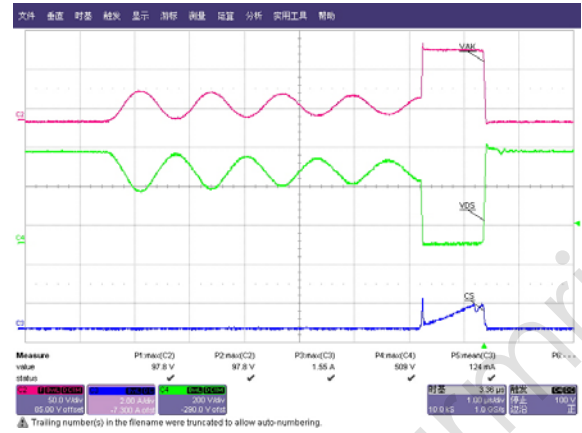

VDS ,CS & VAK normal waveform@264Vac; 1.4A load

4.2.3 VDS ,CS & VAK output short waveform

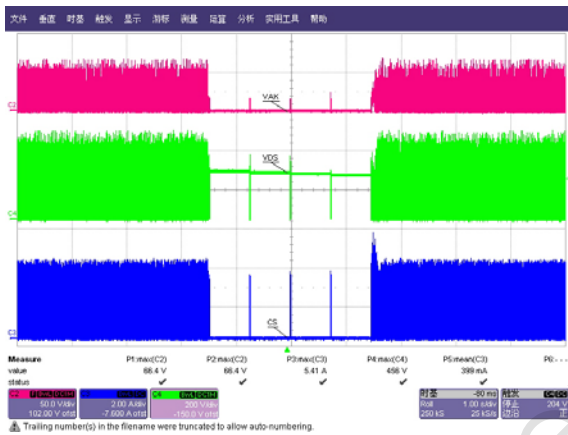

VDS ,CS & VAK output short waveform@90Vac; full load

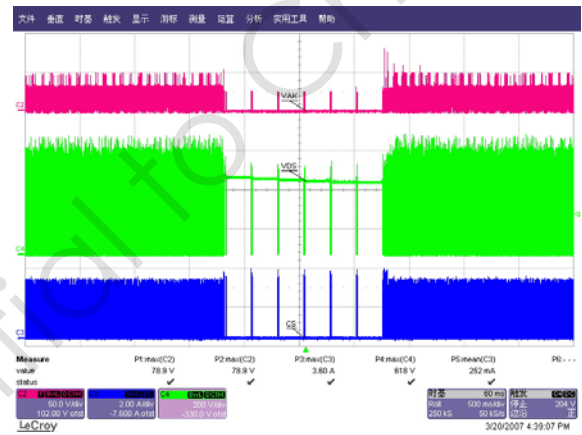

VDS ,CS & VAK output short waveform@264Vac; full load

Disclaimer

On-Bright Electronics reserves the right to make corrections, modifications, enhancements, improvements, and other changes to its documents, products and services at any time and to discontinue any product or service without notice. Customers should obtain the latest relevant information before placing orders and should verify that such information is current and complete.

This document is under copy right protection. Non of any part of document could be reproduced, modified without prior written approval from On-Bright Electronics.