

EBC951_Dimmable LED Driver With iW3617-01

General Design Specification:

1. AC Input Range 180-264Vac, Isolated ac-dc offline, 12LEDS, Output 700mA
2. Intelligent wall dimmer detections(Leading-edge dimmer , Trailing-edge dimmer , No-dimmer)
3. Multiple dimming control scheme
4. Wide dimming range from 1% up to 100%
5. No visible flicker
6. Resonant control to achieve high efficiency
7. High Power Factor, 0.9 without dimmer
8. Temperature degrade control to adjust the LED
9. Primary-only Sensing eliminates opto-isolator feedback and simplifies design

1. Specification

Description	Symbol	Min	Typ	Max	Units	Comment
Input						
Voltage	V_{IN}	180		264	V _{AC}	2 Wire
Frequency	f_{LINE}	47	50/60	63	Hz	
Output						
Output Voltage	V_{OUT}		40		V	Measured at the end of PCB
Output Current	I_{OUT}		0.7		A	
Output Ripple Current	I_{RIPPLE}		35		mA _{P-P}	Set oscilloscope at 20MHz bandwidth.
Total Output Power						
Continuous Output Power	P_{OUT}		28		W	
Performance Factor	PF		0.98			$V_{IN} = 230VAC$
Active Mode Efficiency (EPA2.0 Requirement)	η		88		%	Measured at end of PCB, $V_{IN} = 230VAC$ ($T_{AMB} = 25^{\circ}C$).
Environmental						
THD	THD			10	%	$V_{IN} = 230VAC$
Conducted EMI		Meets CISPR22B / EN55022B				
Safety		Designed to meet IEC950, UL1950 Class II				
Ambient Temperature	T_{AMB}	0		40	$^{\circ}C$	Free convection, sea level

2. Schematic

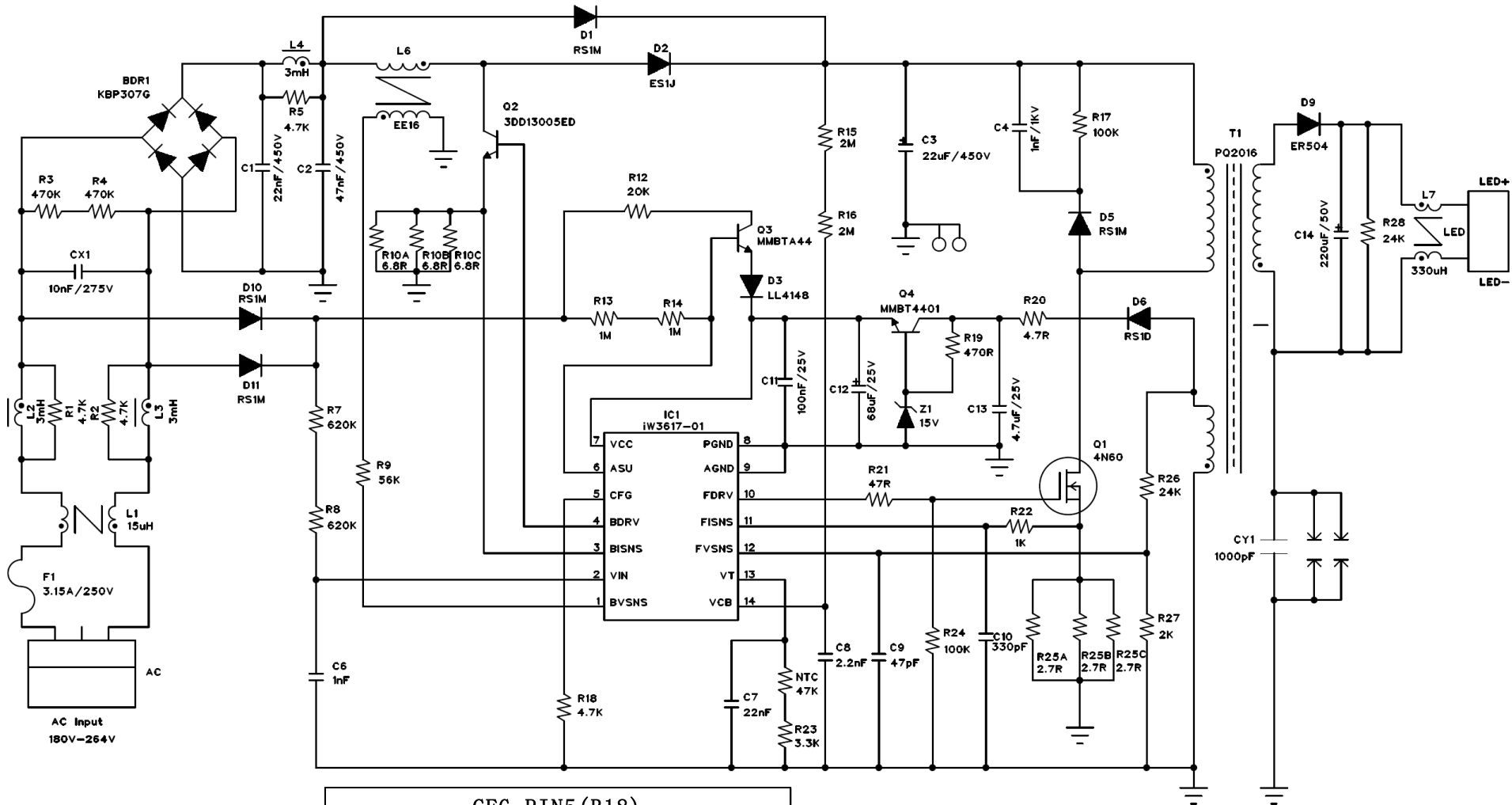

CFG PIN5 (R18)		
00	CC_PFM	0 - 6.65KΩ (4.7KΩ +5%)
01	Amplitude	8.45 - 9.31KΩ (9.1KΩ +1%)

3. Circuit Board Photograph

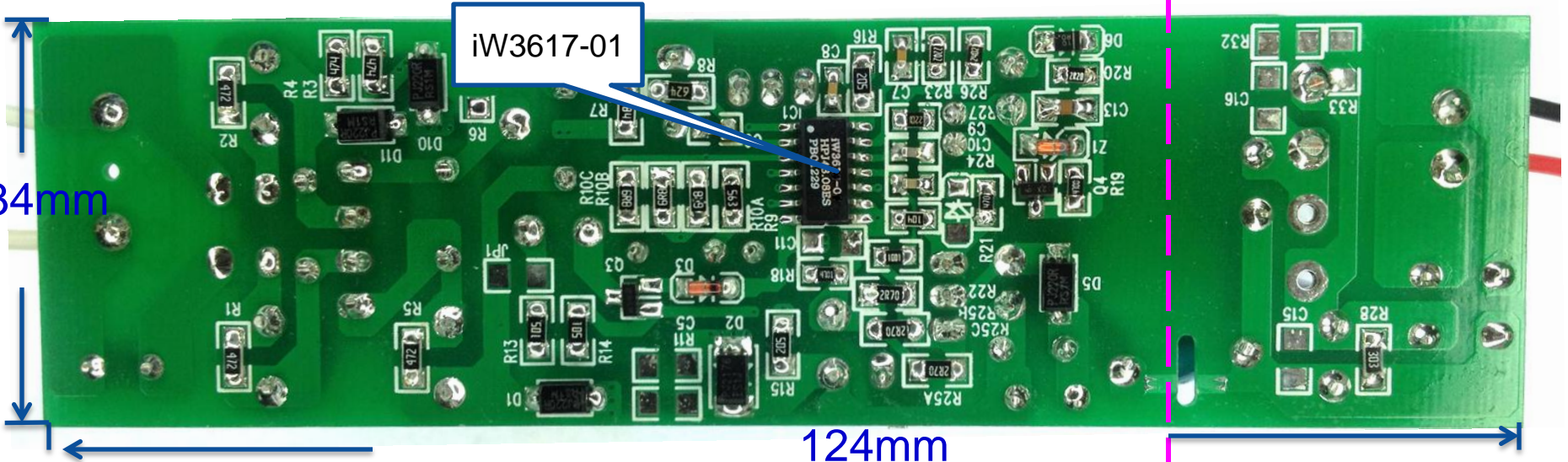
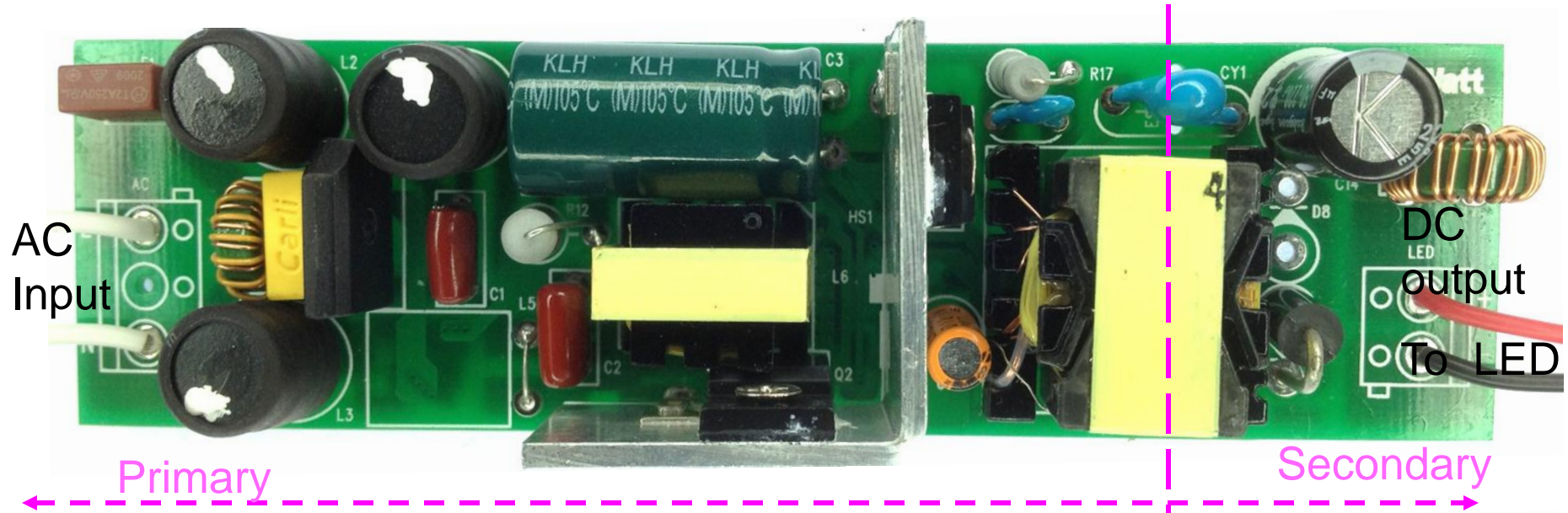

4.BOM

Item	Reference	Description	Qty	Item	Reference	Description	Qty
1	IC1	iW3617-01, Digital PWM Controller, Dimmable, SO-14	1	30	R22	1K Ω \pm 1 %, SMD-0805	1
2	CX1	10nF, 275V, X2, P=7.5mm	1	31	R27	2K Ω \pm 1 %, SMD-0805	1
3	C1	22nF, 450V, CBB21, P=7.5mm	1	32	R26	24K Ω \pm 1 %, SMD-0805	1
4	C2	47nF, 450V, CBB21, P=7.5mm	1	33	R25A, R25B, R25C	2.7 Ω \pm 1 %, SMD-1206	3
5	C3	22uF, 450V, E-CAP	1	34	R10A, R10B, R10C	6.8 Ω \pm 1 %, SMD-1206	3
6	C12	68uF, 25V, E-CAP	1	35	R12	20K Ω , \pm 5 %, MOF	1
7	C14	220uF, 50V, E-CAP	1	36	R17	100K Ω , \pm 5 %, MOF	1
8	C4	Ceramic capacitor, 1nF, 1KV, P=5mm	1	37	F1	FUSE, T3.15A250V	1
9	C9	47pF, 25V, X7R, SMD-0805	1	38	D6	RS1D, 1A, 200V, SMA	1
10	C10	330pF, 25V, X7R, SMD-0805	1	39	D1, D5, D10, D11	RS1M, 1A, 1000V, SMA	4
11	C6	1nF, 25V, X7R, SMD-0805	1	40	D2	ES1J, 1A, 600V, SMA	1
12	C8	2.2nF, 25V, X7R, SMD-0805	1	41	BDR1	KBP307G, 3A, 1000V, KBP	1
13	C7	22nF, 25V, X7R, SMD-0805	1	42	D9	ER504, 5A, 400V, DO-201AD	1
14	C11	100nF, 25V, X7R, SMD-0805	1	43	D3	LL4148, 0.15A, 100V, LL-34	1
15	C13	4.7uF, 25V, X7R, SMD-0805	1	44	Z1	Zener, ZMM15B, 15V, LL-34	1
16	R21	47 Ω \pm 5 %, SMD-0805	1	45	Q1	4N60.4A, 600V, TO-220F	1
17	R20	4.7 Ω \pm 5 %, SMD-0805	1	46	Q4	MMBT4401, NPN, SOT-23	1
18	R19	470 Ω \pm 5 %, SMD-0805	1	47	Q3	MMBTA44, NPN, 0.3A, 500V, SOT-23	1
19	R18	4.7K Ω \pm 5 %, SMD-0805	1	48	Q2	3DD13005ED, NPN, 4A 700V, TO-220HF	1
20	R24	100K Ω \pm 5 %, SMD-0805	1	49	L2, L3, L4	Drum choke, I-shaped 10X12mm, 3mH	3
21	NTC	NTC, SDNT2012X473J47K Ω , SMD-0805	1	50	L1	Common Mode Inductor T8*3*3 15uH	1
22	R23	3.3K Ω \pm 1 %, SMD-0805	1	51	L7	Common Mode Inductor T10*4*6 330uH	1
23	R28	24K Ω \pm 5 %, SMD-1206	1	52	L6	EE16, L=0.8mH	1
24	R13, R14	1M Ω \pm 5 %, SMD-1206	2	53	T1	Transformer, PQ2016, L=0.85mH	1
25	R1, R2, R5	4.7K Ω \pm 5 %, SMD-1206	3	54	CY1	Y1, 1000pF, 400V	1
26	R9	56K Ω \pm 5 %, SMD-1206	1	55	AC	connector, 3PIN2,, P=5.0mm	1
27	R3, R4	470K Ω , \pm 5 %, SMD-1206	2	56	LED	connector, 2PIN,, P=5.0mm	1
28	R15, R16	2M Ω \pm 1 %, SMD-1206	2	57	PCB	FR-4, Tw o-layout, 124*34mm	1
29	R7, R8	620K Ω , \pm 1 %, SMD-1206	2	58			

5. Transformer Design

SCHEMATIC

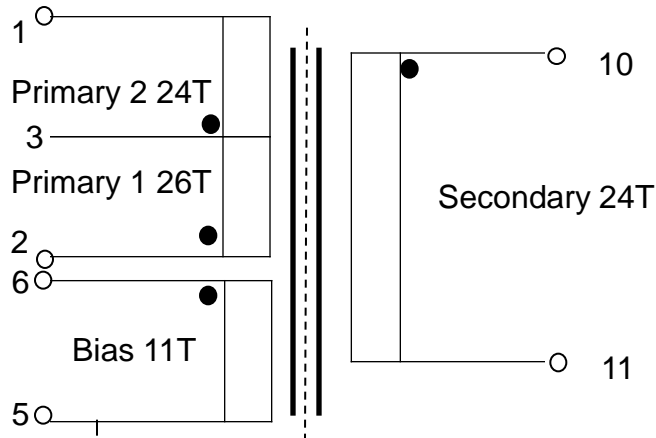

ELECTRICAL SPECIFICATIONS:

1. Primary Inductance (L_p) = 0.85mH @10KHz
2. Primary Leakage Inductance (L_k) ≤ 15uH@60KHz
3. Electrical Strength = 3KV, 50/60Hz, 1Min

MATERIALS:

1. Core : PQ2016 (Ferrite Material TDK PC40 or equivalent)
2. Bobbin : PQ2016 Vertical Primary=6, Secondary=8
3. Magnet Wires (Pri) : Type 2-UEW
4. Magnet Wire (Sec) : Triple Insulated Wires
5. Layer Insulation Tape : 3M1298 or equivalent.

FINISHED :

1. Cut remained of Pin3,4,7,8,9,12,13,14 after wires termination
2. Core is connected to PRI-GND Pin5.
3. Varnish the complete assembly

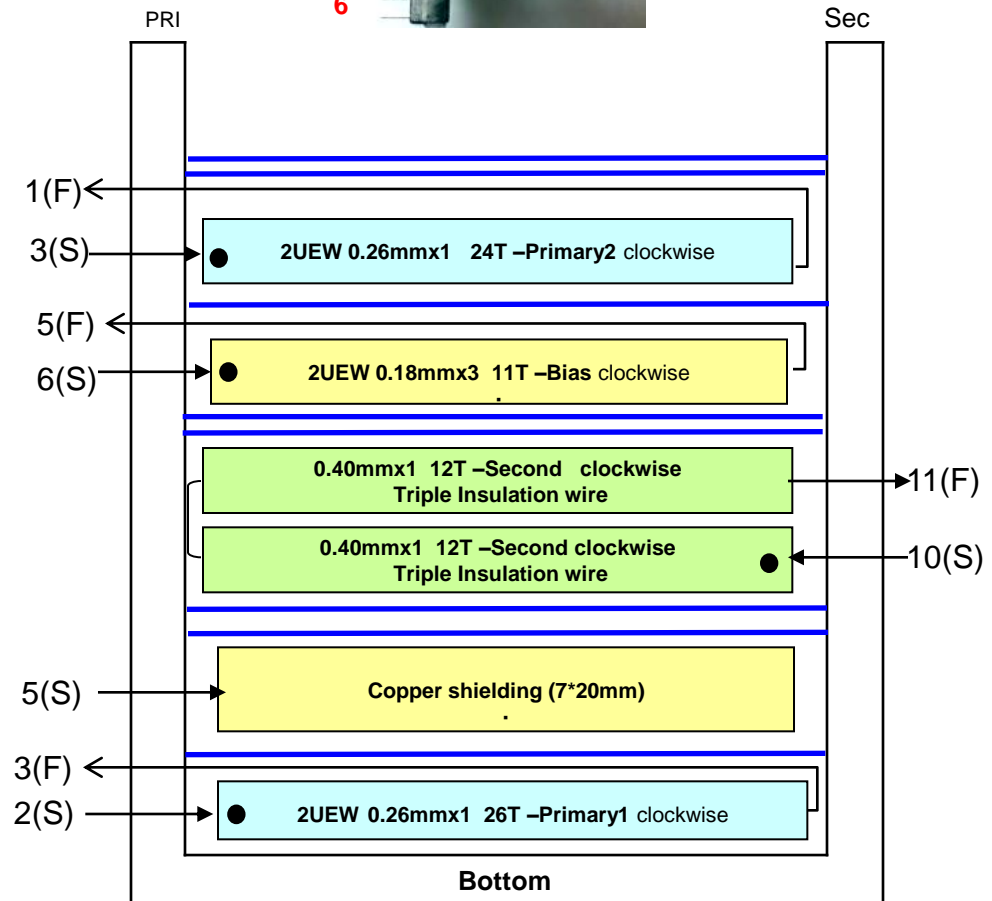
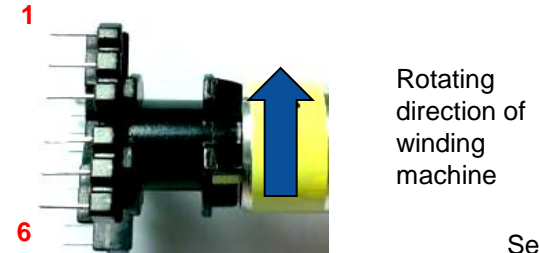

6. PFC Boost Inductor

SCHEMATIC

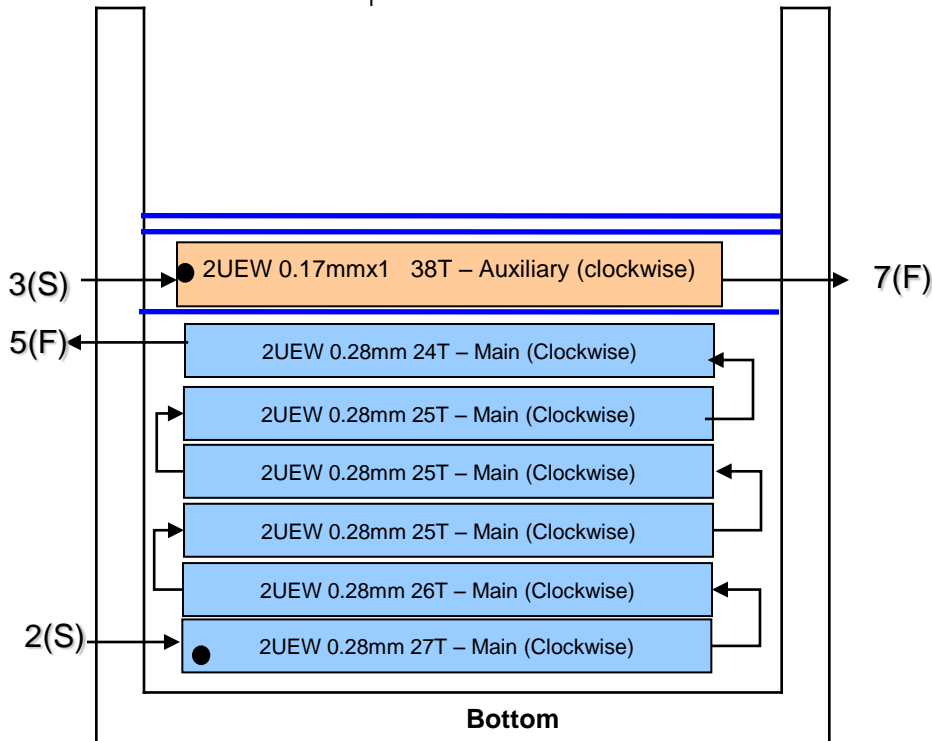
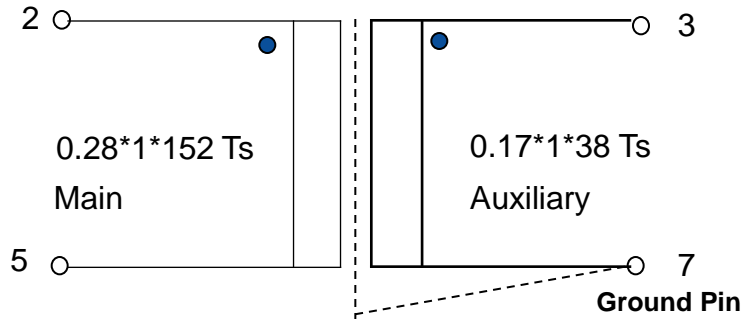

ELECTRICAL SPECIFICATIONS:

1. Inductance (L_{p2-5}) = 0.8mH @10KHz
2. Core : EE16 (Ferrite Material TDK PC40 or equivalent)
3. Bobbin : EE16 Vertical
4. Ferrite core is connected to Pin 7 after assembling
5. Cut Pin 1,4 ,6,8,9,10 after wires termination
6. Varnish the complete assembly

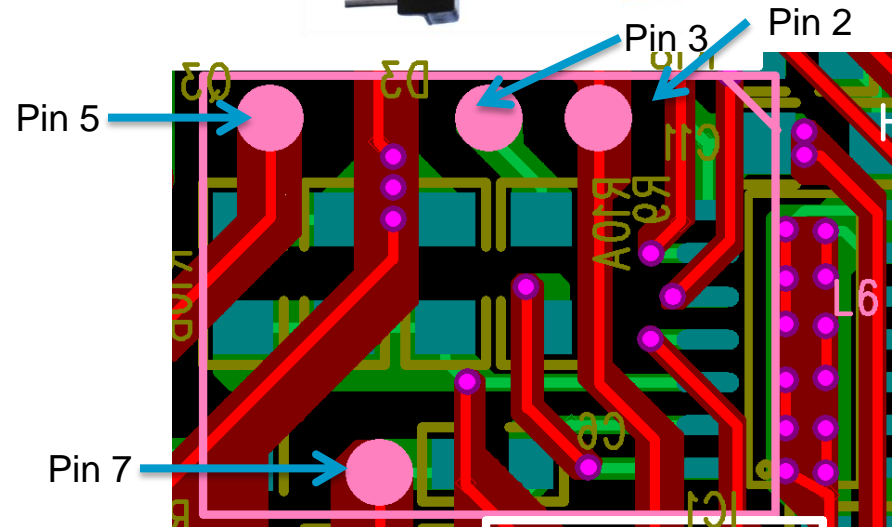
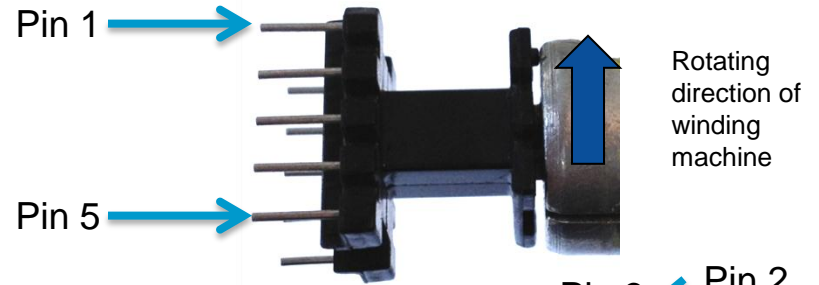

7. EMI choke

Inductor L2 L3 L4

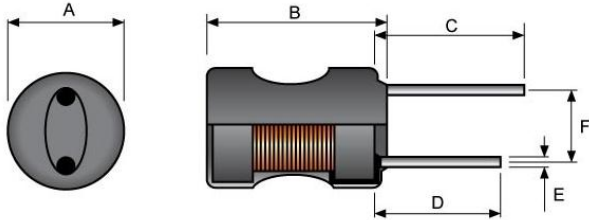

Ferrite core size : Ax B 10x12mm
Wire gauge: 0.23mm, 271Turns
Inductance @10kHz, 1V: 3mH +/-30%
ICR: 2.7 OHM +/-20%

Common Mode Inductor L1



Core size:T8*3*3
Wire gauge: 0.35mm*2(Insulation& 2-UEW wire)
Turns:6T
Inductance @10kHz, 1V: 15uH +/-20%
ICR: 0.2 OHM +/-20%

Common Mode Inductor L7



Core size:T10*4*6
Wire gauge: 0.6mm*2(2-UEW wire)
Turns:8T
Inductance @60kHz, 1V: 330uH +/-20%
ICR: 0.3 OHM +/-20%

8. Regulation, Ripple and Efficiency Measurement

$V_{IN}=180Vac \sim 264Vac/50Hz$; Loading with 12LEDs 700mA

Vin	Pin	Vout	Iout	Ripple(PK)	efficiency	PF	Vbulk
(V)	(W)	(V)	(mA)	(mA)			(V)
180	31.71	39.52	708	26.0	88.24%	0.999	264
190	31.66	39.51	708	26.0	88.35%	0.998	278
200	31.56	39.50	708	25.2	88.61%	0.998	310
210	31.56	39.48	708	25.2	88.57%	0.998	325
220	31.56	39.46	708	25.2	88.52%	0.997	336
230	31.57	39.45	708	25.2	88.47%	0.997	364
240	31.57	39.43	709	24.4	88.55%	0.997	374
250	31.53	39.42	709	24.4	88.64%	0.996	387
264	31.49	39.41	709	24.0	88.73%	0.991	387

9. Variable Input Vs. Efficiency Measurement

$V_{IN}=180Vac \sim 264Vac/50Hz$; Loading with 12LEDs 700mA

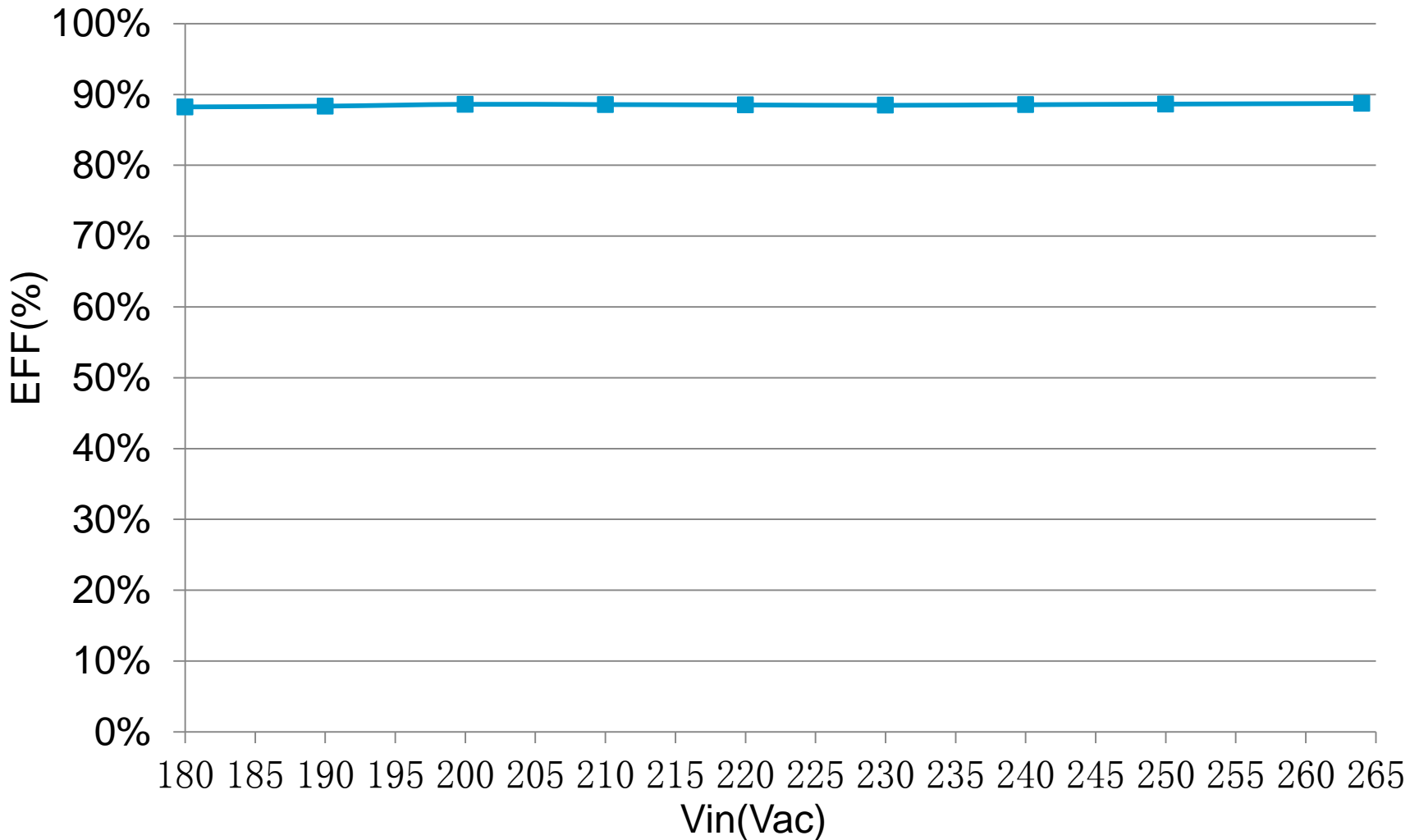

10. Variable Input Vs. Iout Measurement

$V_{IN}=180Vac \sim 264Vac/50Hz$; Loading with 12LEDs 700mA

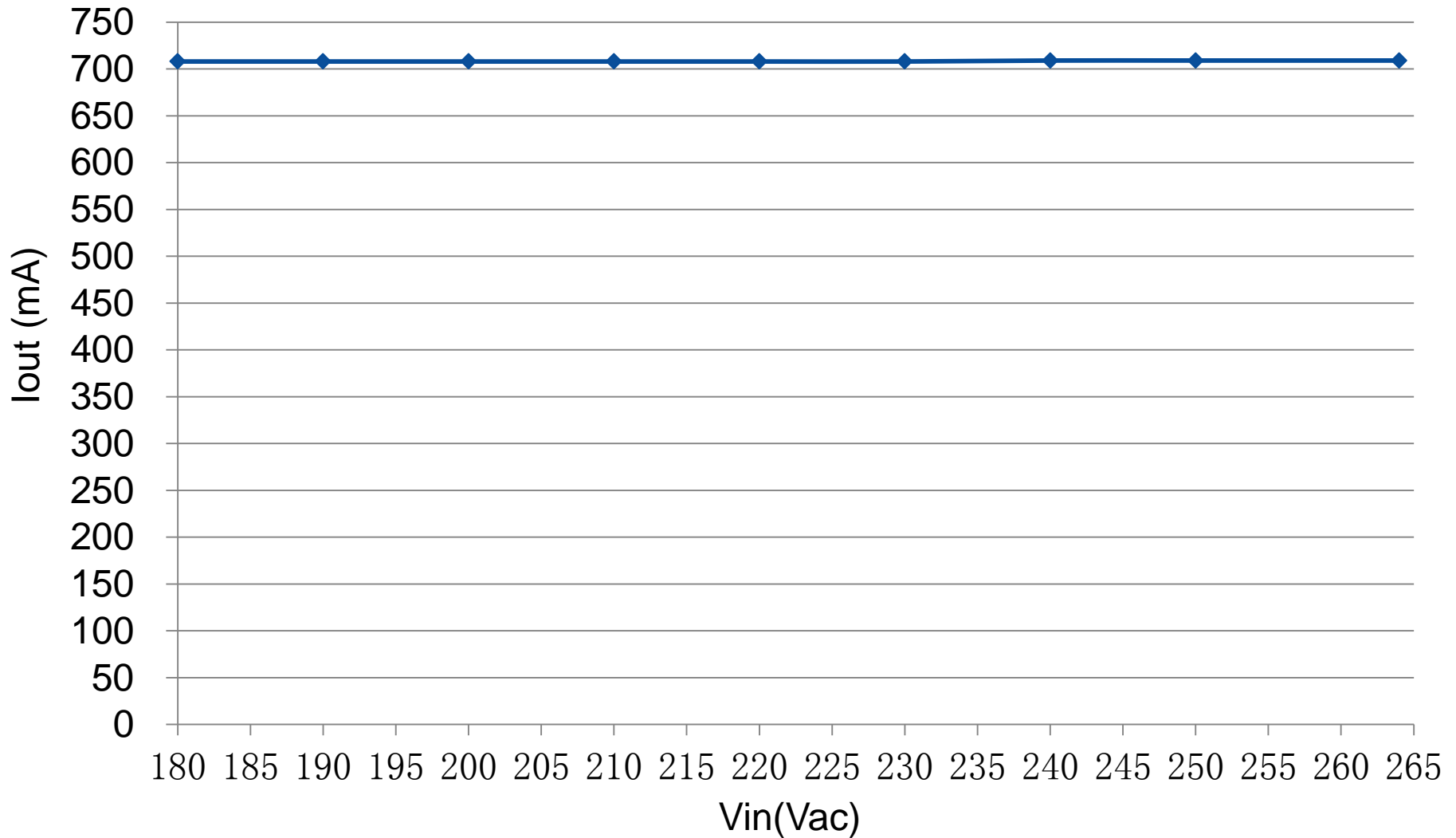

11. Variable Input Vs. PF Measurement

$V_{IN}=180Vac \sim 264Vac/50Hz$; Loading with 12LEDs 700mA

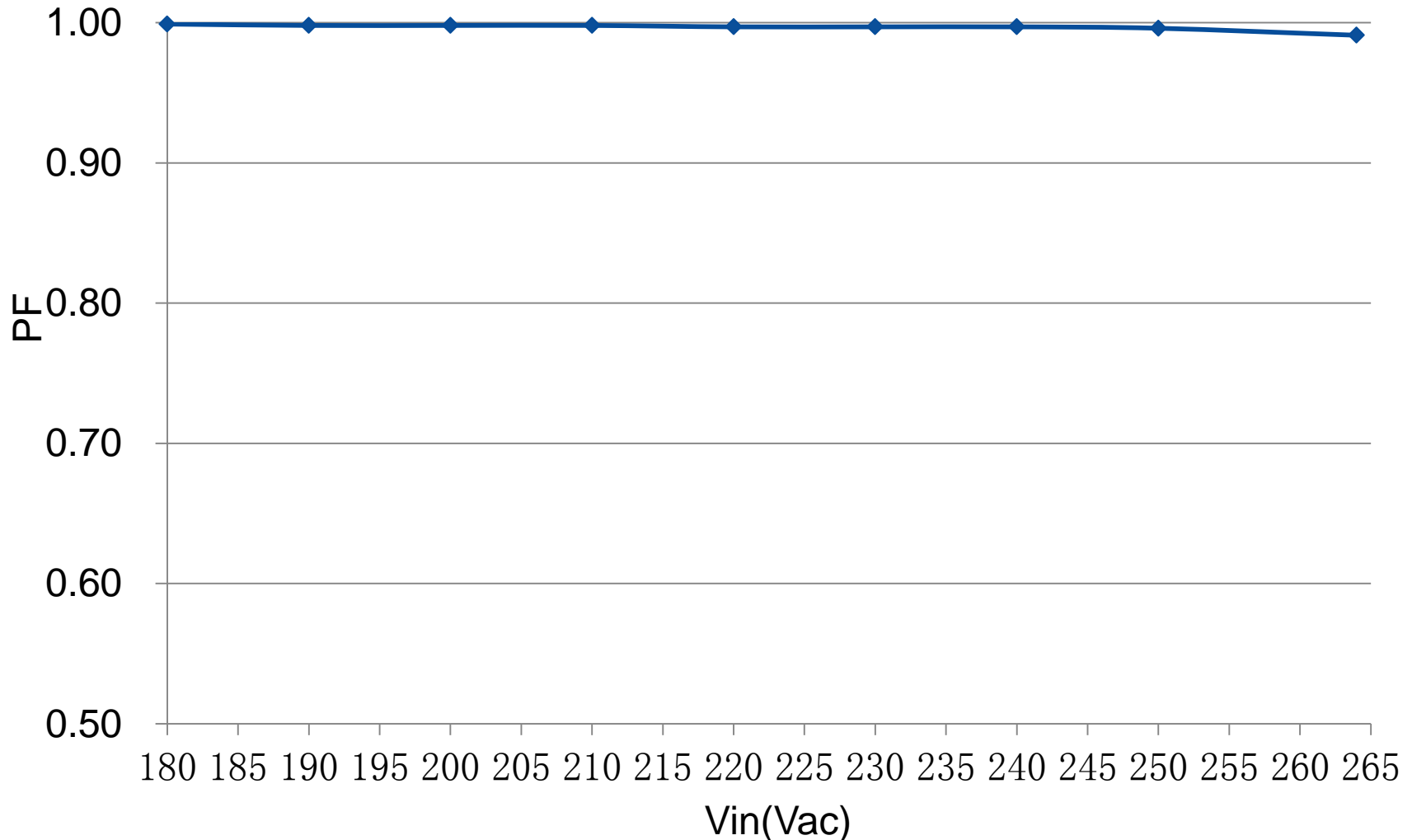

12. Variable Input Vs. Vbulk Measurement

$V_{IN}=180\text{Vac} \sim 264\text{Vac}/50\text{Hz}$; Loading with 12LEDs 700mA

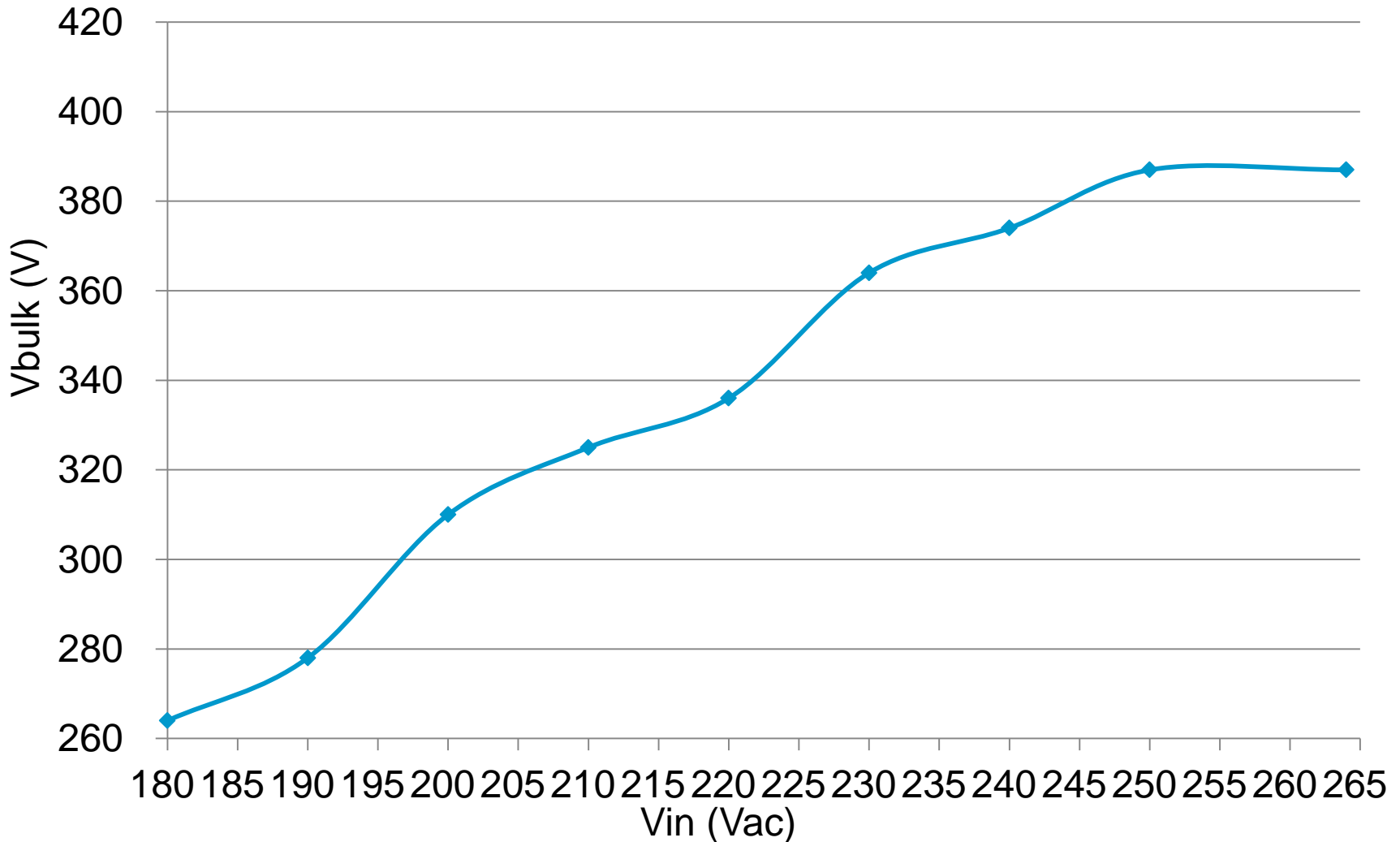

13. Output VI Characteristics(CV Mode)

$V_{IN}=180Vac/50Hz$

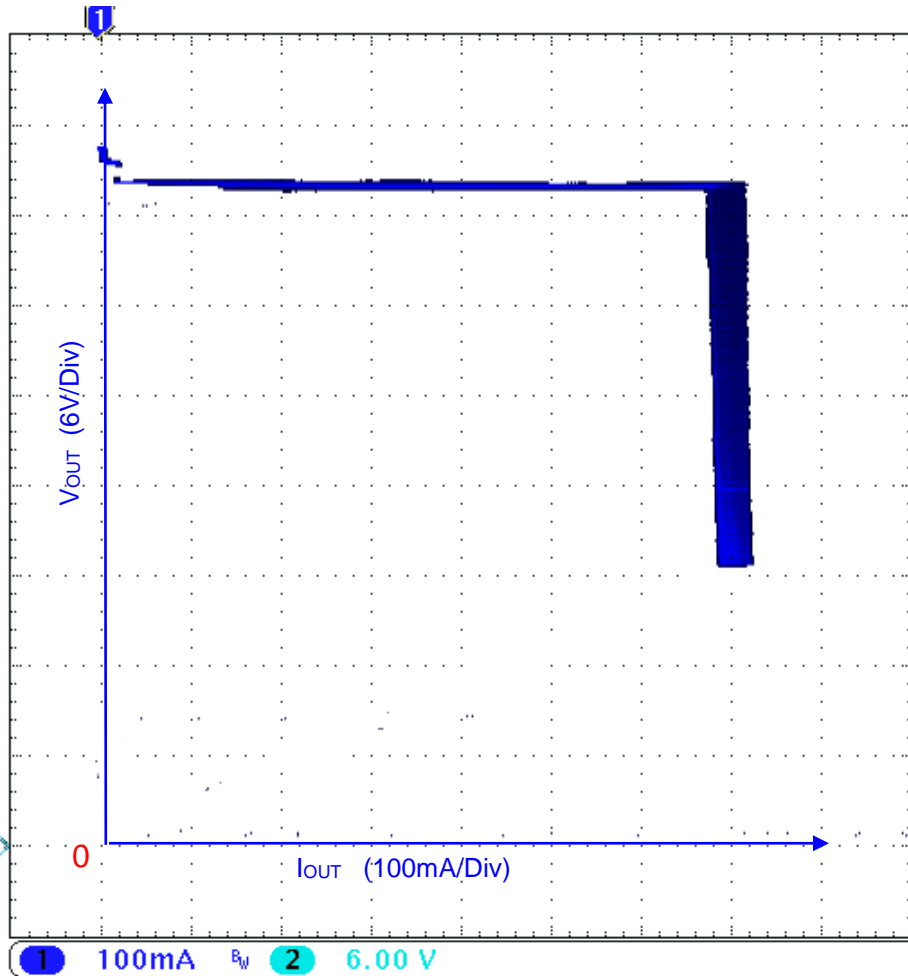

$V_{IN}=264Vac/50Hz$

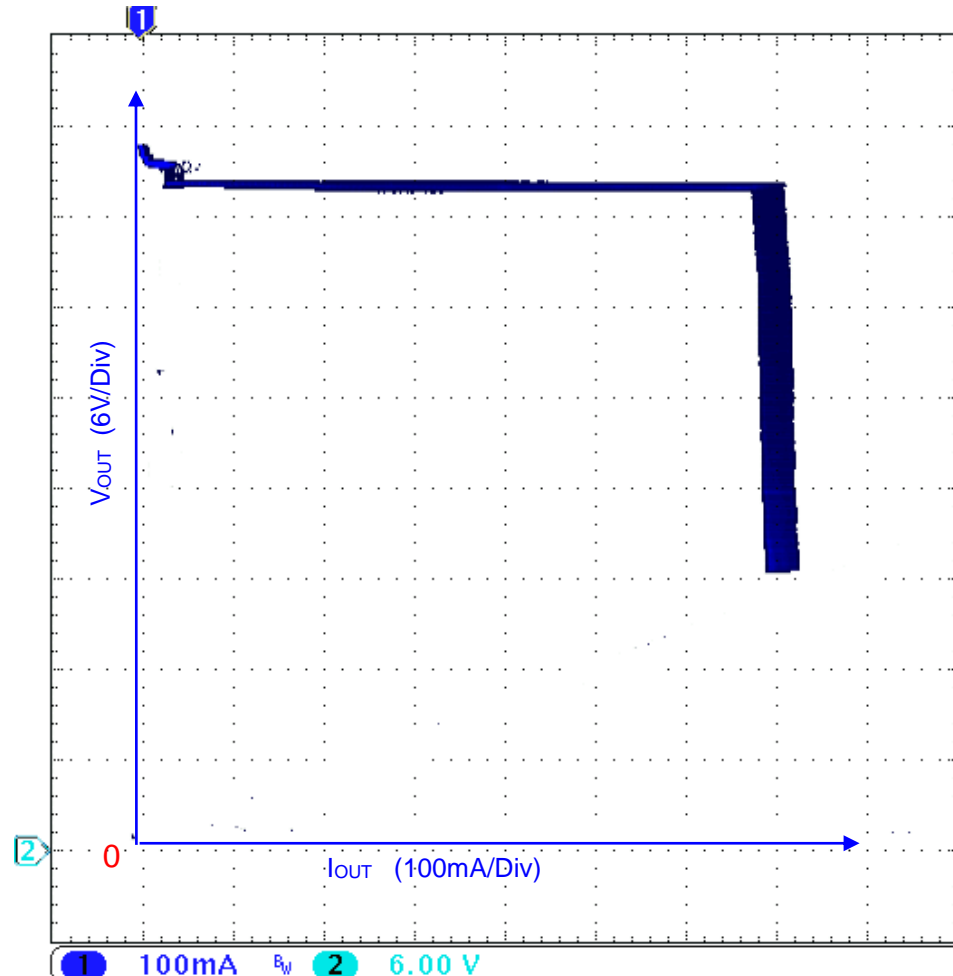

* Note: Output voltage is monitored at end of PCB

14. Dimming range with dimmer

Leading edge dimmer test _ WUYOU W13-C142_ 12 LEDs								
Vin	DIM Level	Pin	LED Voltage	LED current	Pout	Eff	Angle percenta	VCC
(V)		(W)	(V)	(mA)	(W)	(%)	(%)	(V)
180	Max.	32.54	39.39	715	28.16	86.6%	82.8	14.64
		17.03	37.57	351	13.19	77.4%	54.0	15.58
	Min.	1.09	32.18	2	0.06	5.9%	15.2	8.29
230	Max.	32.48	39.33	716	28.16	86.7%	83.2	14.66
		17.52	37.62	365	13.73	78.4%	54.4	14.60
	Min.	1.10	32.14	2	0.06	5.8%	15.2	8.29
264	Max.	32.55	39.30	716	28.14	86.4%	85.6	14.67
		17.74	37.52	355	13.32	75.1%	53.2	14.61
	Min.	1.37	32.74	5	0.16	11.9%	14.4	9.55
Trailing edge dimmer test___ Etman ETM321S 315W___ 12 LEDs								
Vin	DIM Level	Pin	LED Voltage	LED current	Pout	Eff	Angle percenta	VCC
(V)		(W)	(V)	(mA)	(W)	(%)	(%)	(V)
180	Max.	32.69	39.24	712	27.94	85.5%	77.6	14.72
		16.25	37.51	361	13.54	83.3%	68.8	14.65
	Min.	1.96	33.39	14	0.47	23.9%	29.2	11.29
230	Max.	32.29	39.23	709	27.81	86.1%	79.6	14.70
		16.56	37.53	363	13.62	82.3%	66.4	14.65
	Min.	2.44	33.37	14	0.47	19.1%	28.0	11.29
264	Max.	32.15	39.22	709	27.81	86.5%	80.0	14.70
		16.13	37.45	351	13.14	81.5%	64.0	14.63
	Min.	3.06	33.88	25	0.85	27.7%	32.8	12.08

15. VT Pin voltage and output presence

$V_{IN}=230Vac/50Hz$; Possible for OTP with NTC

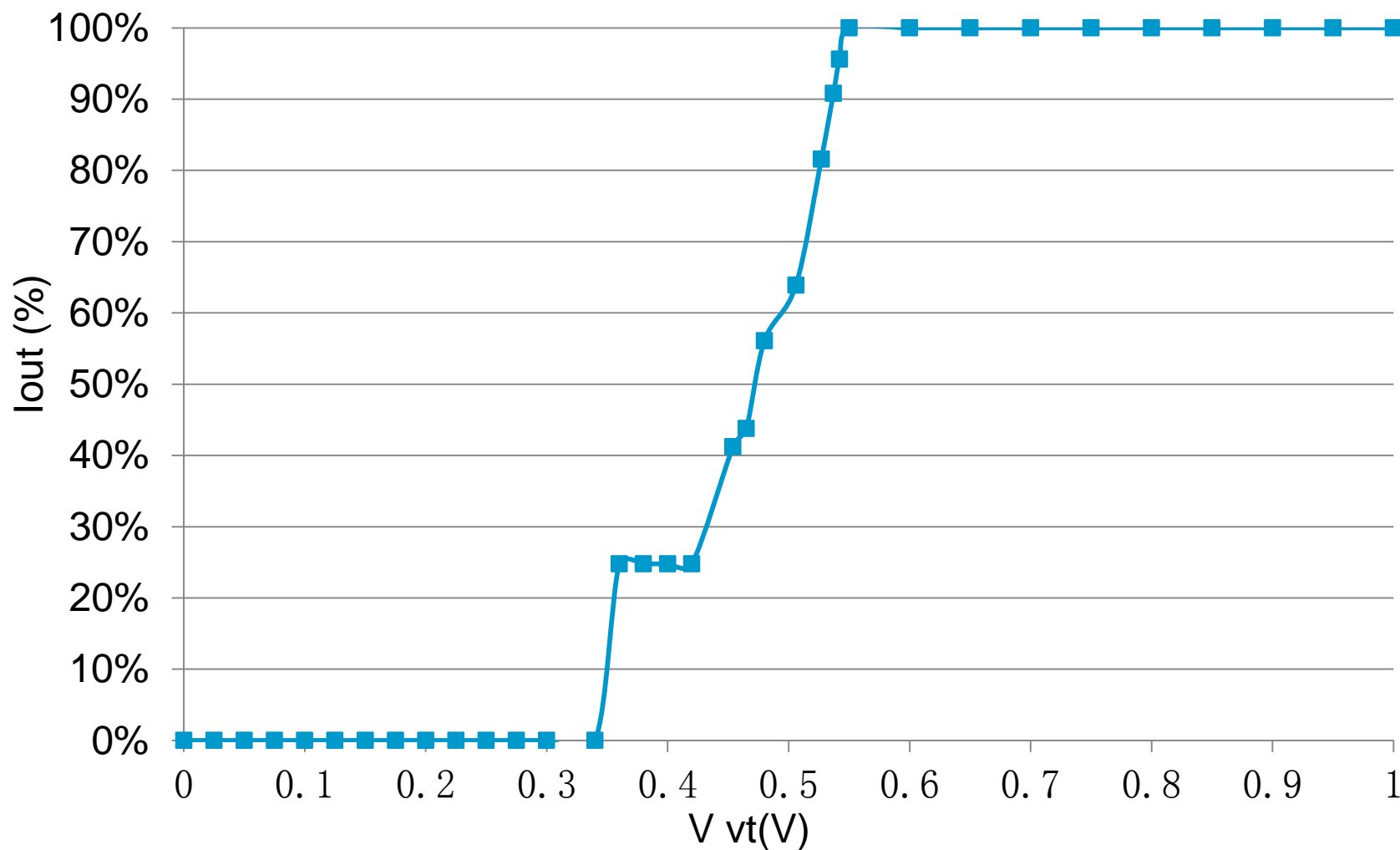

16. Harmonic and current waveform

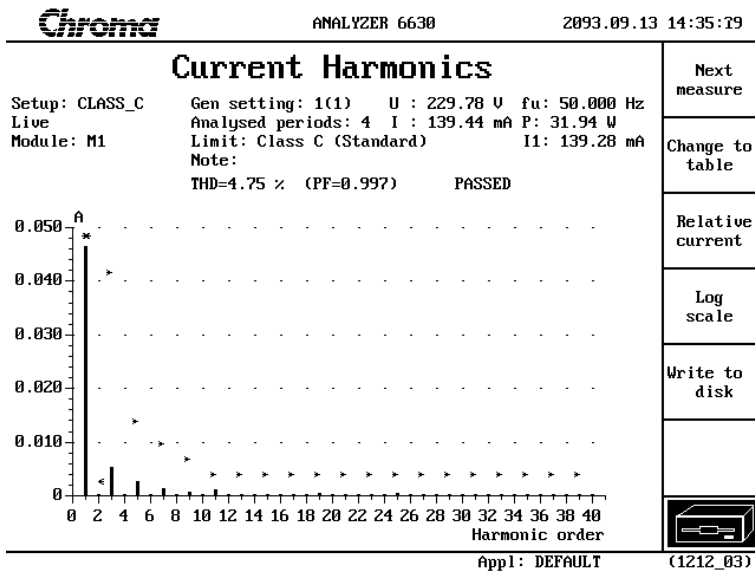

Harmonics current @230Vac THD=4.75%

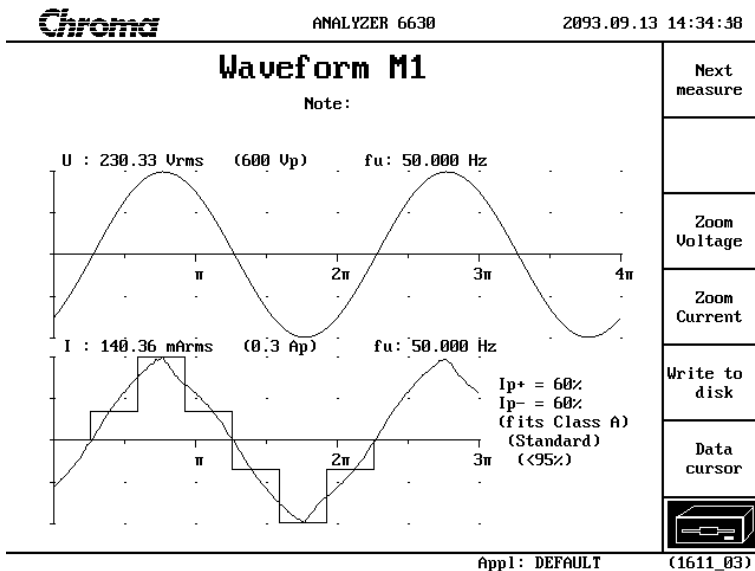

AC current waveform @230Vac PF=0.997

17. Turn-on Delay Time

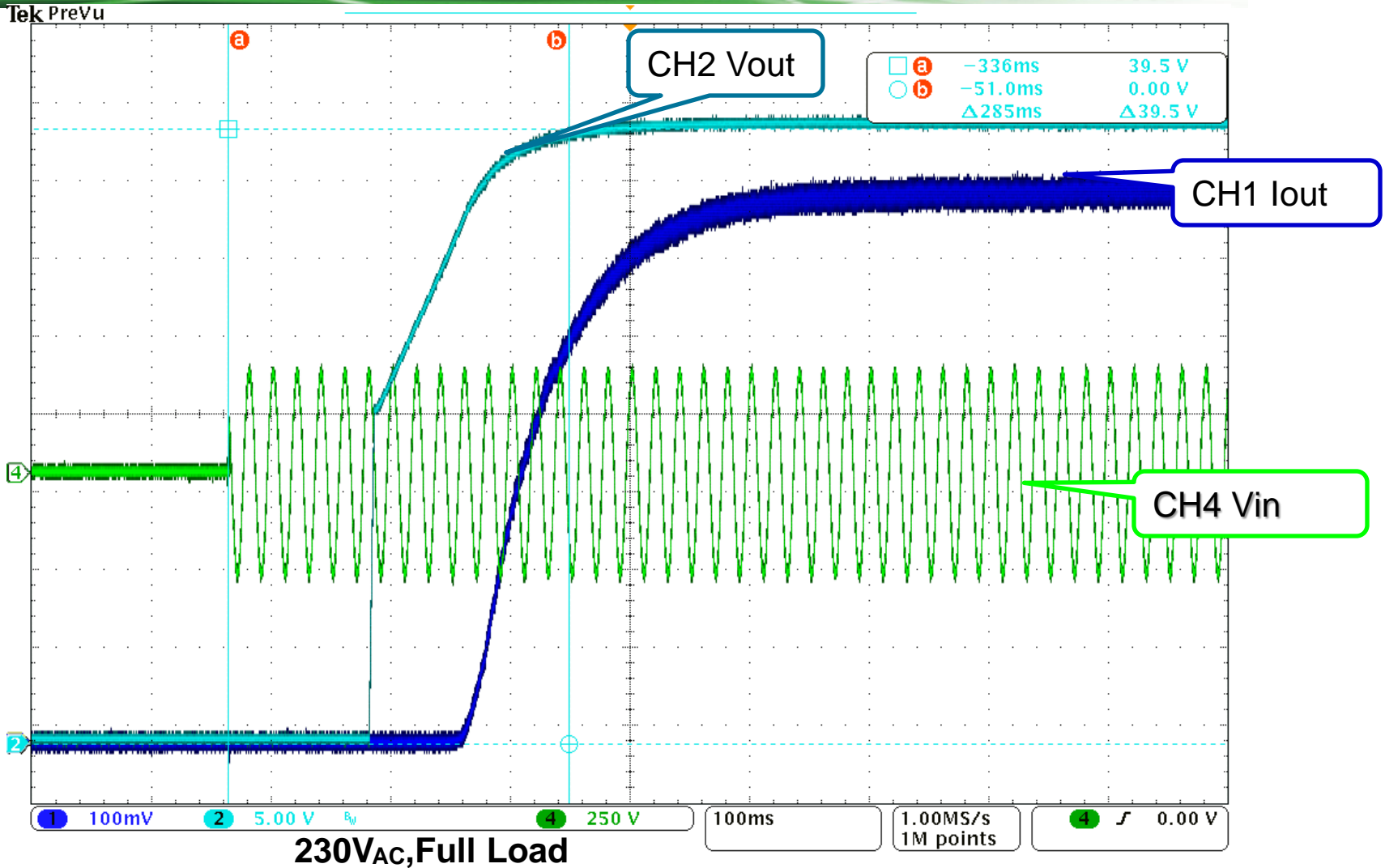

$T_{ST_DELAY} = 285\text{ms}$

18. Transformer Flux Density

($N_p=50T_s$, $L_m=0.85mH$, $A_e=62mm^2$ -PQ2016)

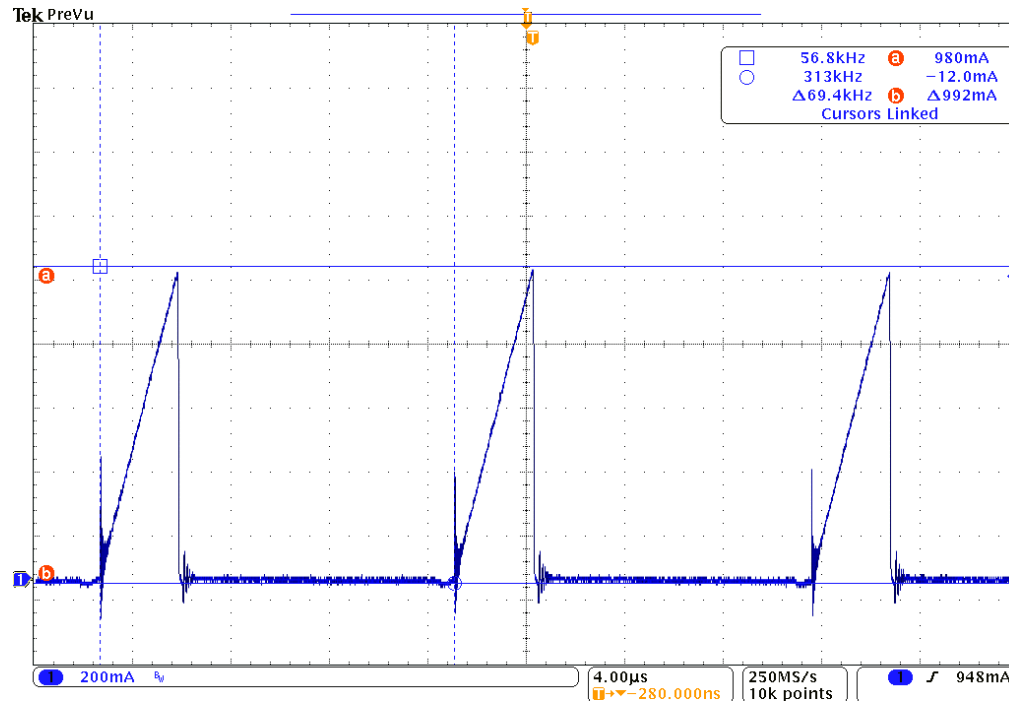

CH1: I_{PRI} ,200mA/div

15 Aug 2012
17:19:11

I_{PRI} is monitored at 180Vac and 0.708A load

$I_{PRI}=992mA$

$B_{MAX} = I_{PRI} * L_{PRI} / (N_p * A_e)$

$= (992 * 0.85) / (50 * 62)$

$= 0.272 Tesla$

19. Q1 MOSFET V_{DS} Waveform

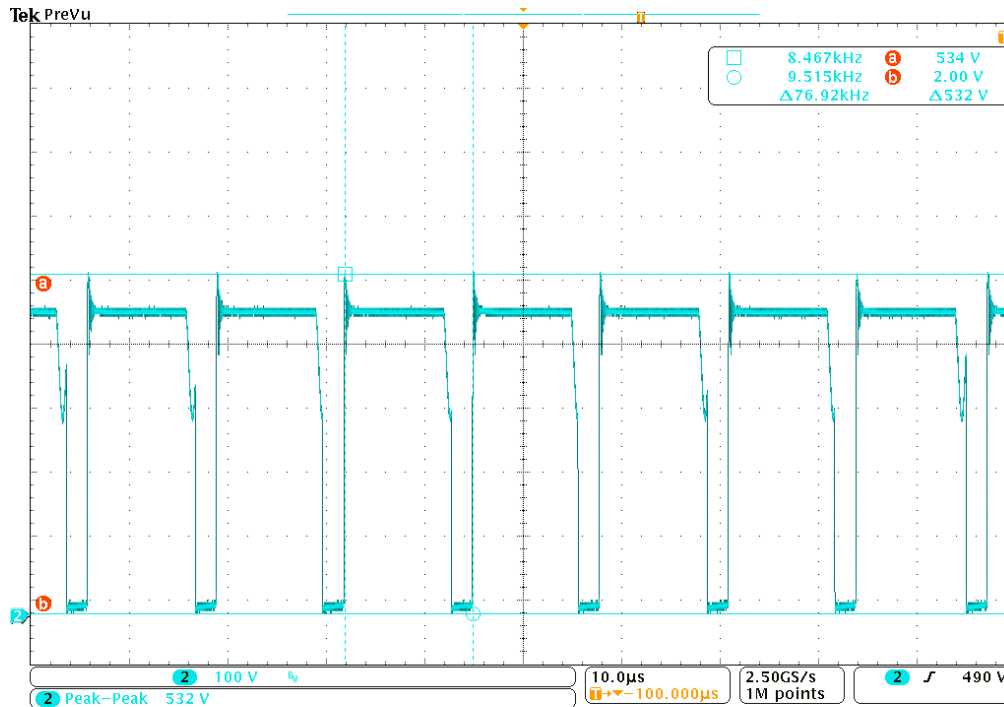

Test Condition:

$V_{IN}=264V_{ac}$, $V_{OUT}=40V$

Result:

$V_{DS_MAX}=532V$

Remark: Mosfet Spec__4A 600V

20. Output Diode Waveform

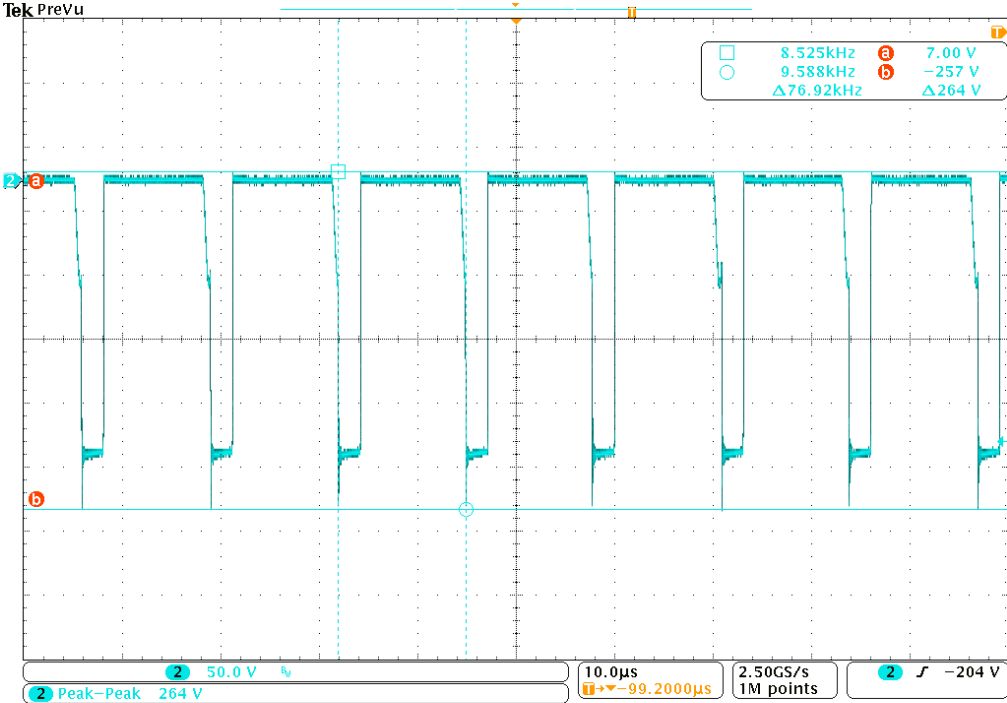

Test Condition:

$$V_{IN}=264V_{ac}, V_{OUT}=40V$$

Result:

$$V_{RRM_MAX}=264V$$

Remark: Diode Spec__5A 400V

21. Vcc Diode waveform

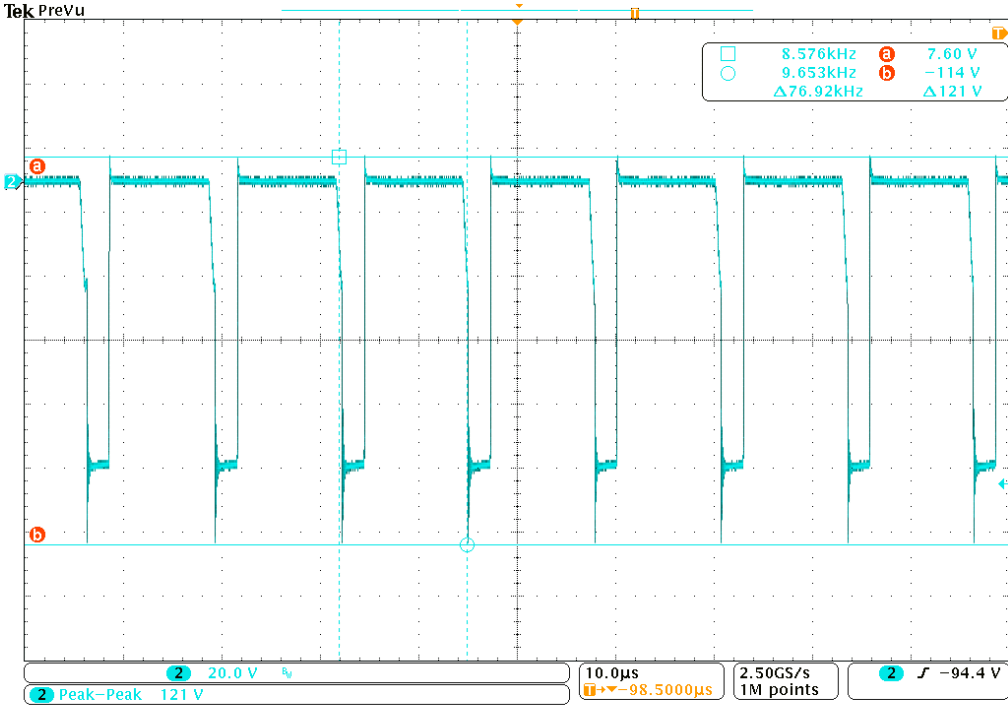

Test Condition:

$V_{IN}=264V_{ac}$, $V_{OUT}=40V$

Result:

$V_{RRM_MAX}=121V$

Remark: Diode Spec__ 1A 200V

22. Conducted EMI (Full Load)

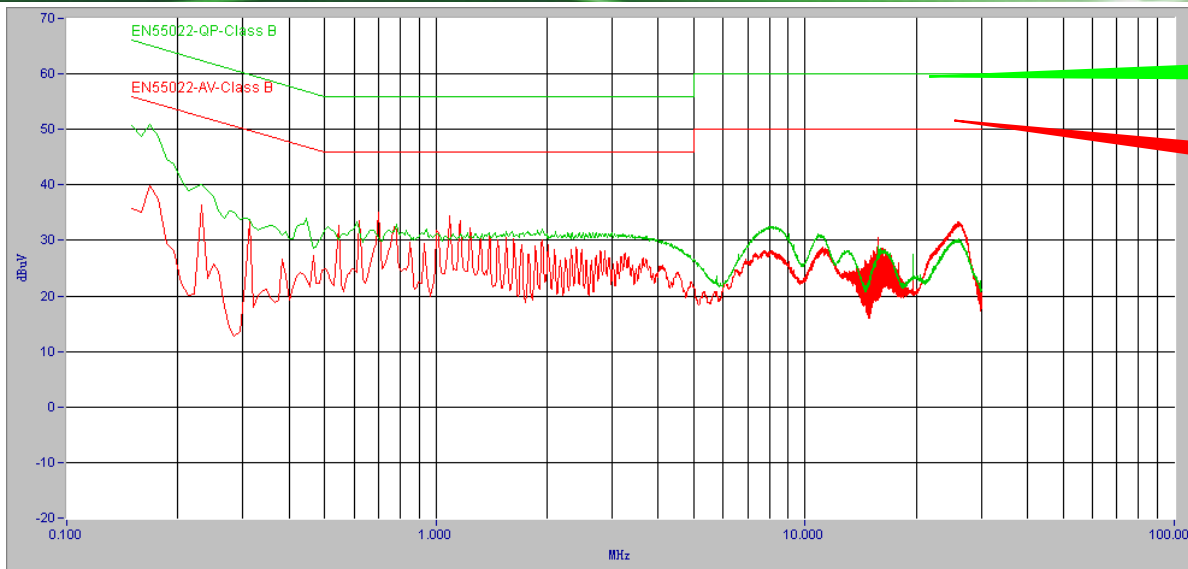

QP Scan
QP Limit line

AV Scan
AV Limit line

Input=230VAC
L line QP&AV scan

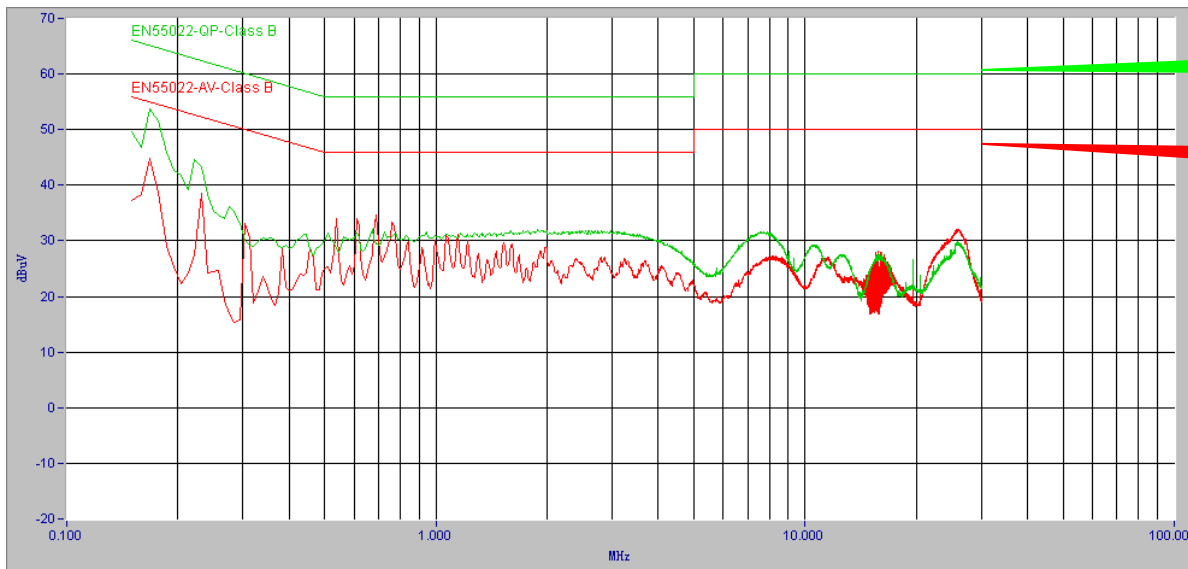

QP Scan
QP Limit line

AV Scan
AV Limit line

Input=230VAC
N line QP&AV scan

23. Radiated EMI (for reference)

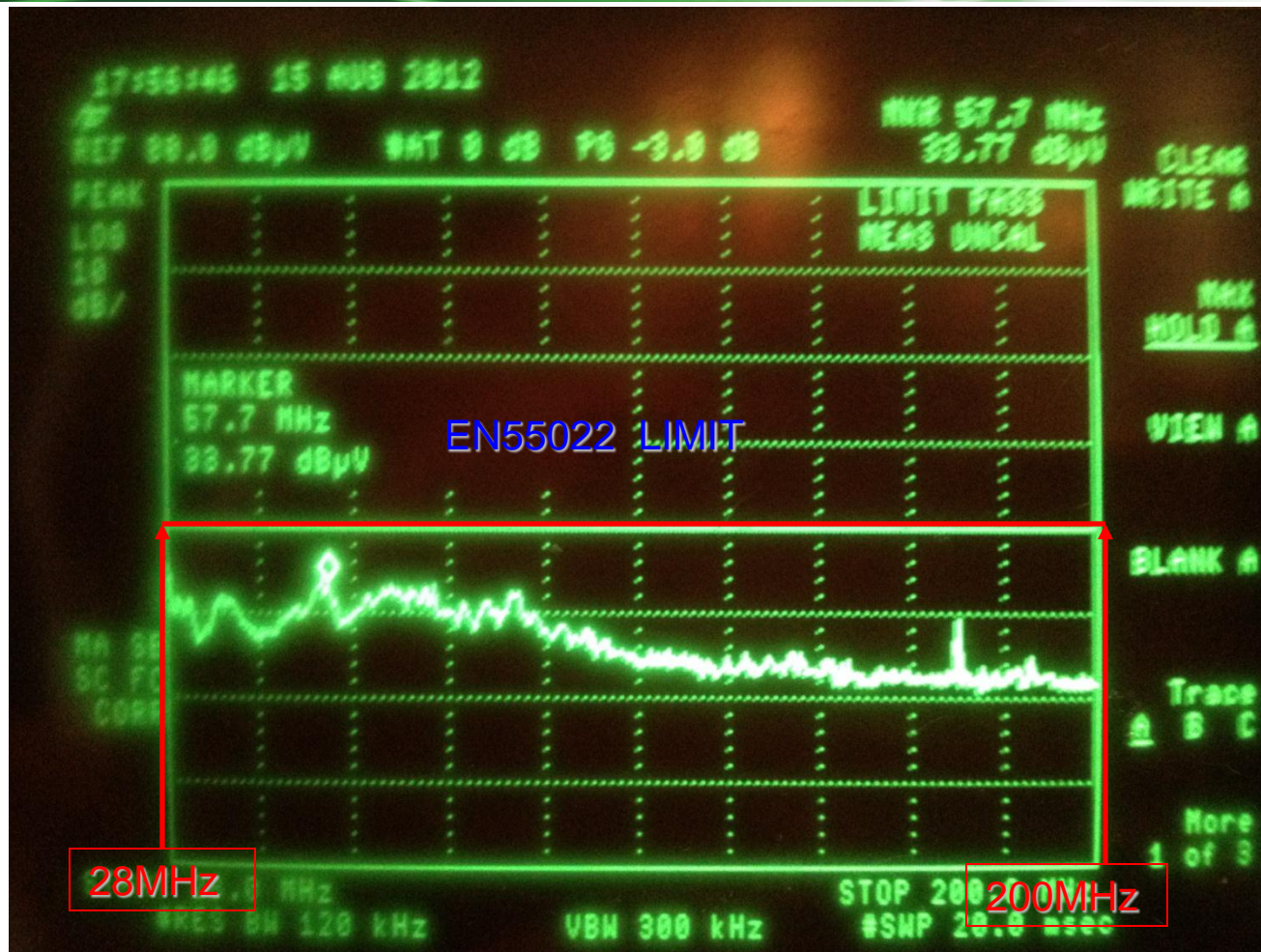

Note: 1, $V_{in}=230V_{ac}$

2, Output is floating