

# AT7381

Universal High Brightness LED Driver (Patented)



Immense Advance Tech.

## FEATURES

- Universal Rectified 90VAC to 264VAC Input Voltage Range
- Built-in Active Power Factor Correction Technique
- Low THD, meet with IEC-61000-3-2 Class-C
- High Efficiency Application
- Built-in Output Short Circuit Protection with Auto-Recovery
- Built-in Output Over Voltage Protection with Auto-Recovery
- Built-in Gate Clamp
- Cycle-by-cycle Current Limit
- Fail-Safe, Output is not subjected to line voltage if the MOSFET fails.
- Excellently Accurate Constant Current
- Very Tight Line and Load Regulation
- Constant Off-Time
- Buck or Buck-Boost Configuration

## DESCRIPTION

The AT7381 is a controller for off-line LED converter. The AT7381 operate with constant off-time, peak current mode control with active power factor correction function. The controller senses real-time switch current to cycle-by-cycle current limit. Cycle-by-cycle current limit at the CS pin ensure a safe operation during short-circuit at the output. It can be configured in either buck-boost (Figure1) or buck (Figure2) application circuit. The driver output voltage is limited to 19V to protect external power MOSFET. The controller also monitors integrated actual LED current to perform the excellent line and load regulation. The controller makes the inductor current to follow the shape of input voltage to perform high power factor and low THD solution.

The AT7381 provides complete protection features such as short-circuit and open-circuit protection.

## APPLICATIONS

- AC/DC LED Driver Application
- DC/DC LED Driver Application
- Signage and Decorative LED Lighting
- Residential Lighting

## ORDER INFORMATION

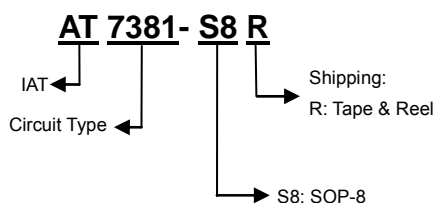

## PIN CONFIGURATIONS (TOP VIEW)

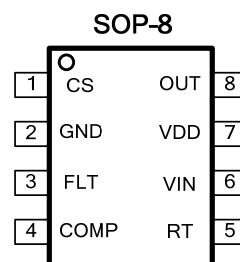

# AT7381

Universal High Brightness LED Driver (patented)



Immense Advance Tech.

## PIN DESCRIPTIONS

Pin Name	Pin Description
CS	Switch current sense pin.
GND	IC ground and reference.
FLT	Actual output current sensing pin.
COMP	Output pin of error amplifier.
RT	Constant off-time setting.
VIN	AC-Line voltage sensing pin.
VDD	Power supply pin for all internal circuit.
OUT	Power MOSFET driver output.

## TYPICAL APPLICATION CIRCUITS

### Buck-Boost Topology

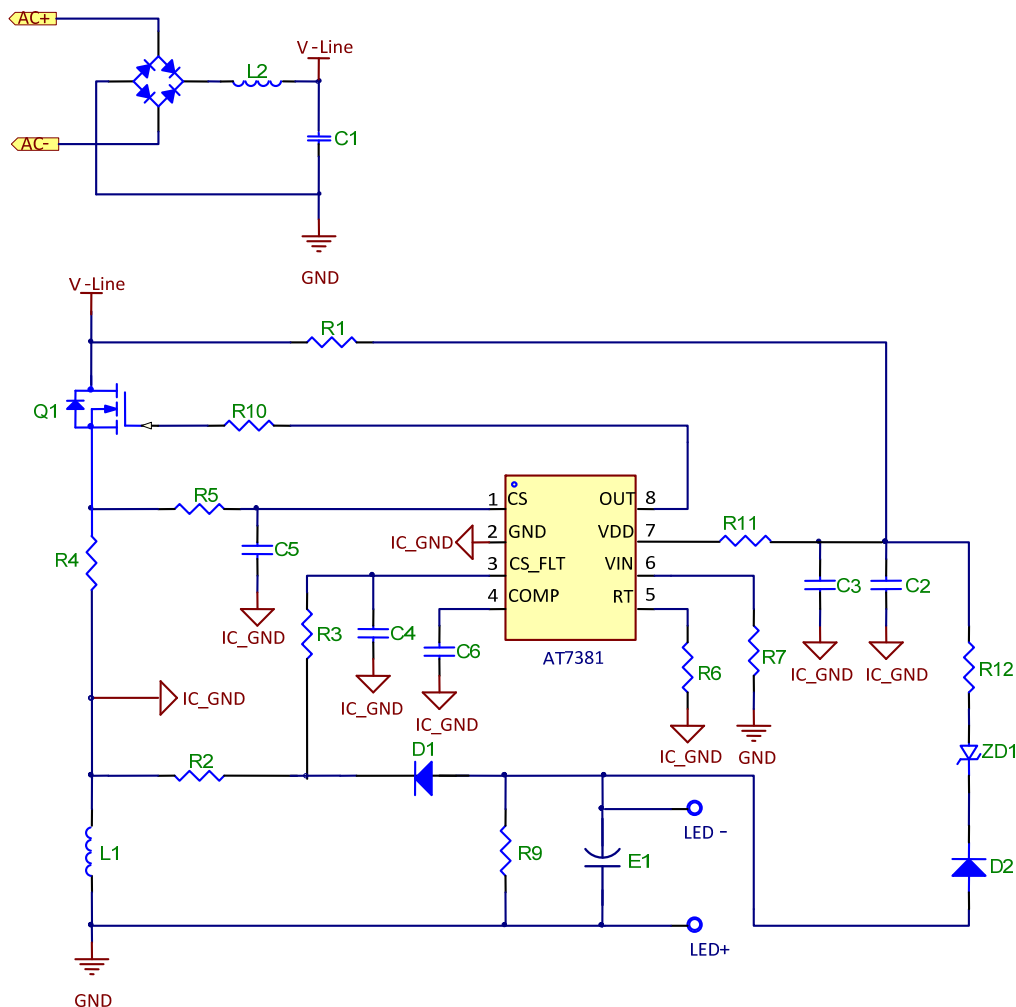

Figure 1

# AT7381

Universal High Brightness LED Driver (patented)



Immense Advance Tech.

## Buck Topology

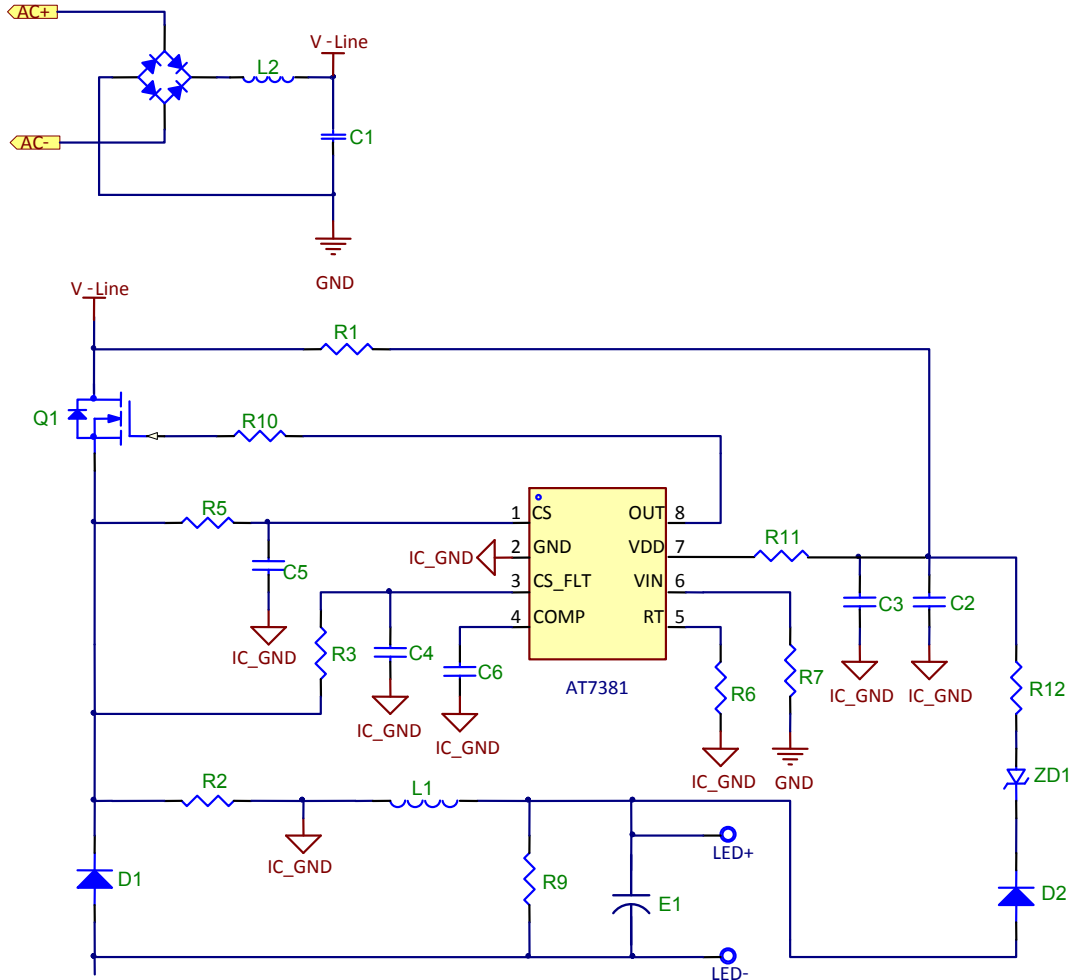

Figure 2

# AT7381

Universal High Brightness LED Driver (patented)



Immense Advance Tech.

## ABSOLUTE MAXIMUM RATINGS (Note 1)

Parameter	Symbol	Range	Unit
Power supply pin	$V_{DD}$	-0.3 to 30	V
CS voltage to GND	$V_{CS}$	-0.3 to 5	V
FLT voltage to GND	$V_{FLT}$	-0.3 to 5	V
COMP voltage to GND	$V_{COMP}$	-0.3 to 5	V
VIN voltage to GND	$V_{IN}$	-0.3 to 5	V
RT voltage to GND	$V_{RT}$	-0.3 to 5	V
OUT voltage to GND	$V_{OUT}$	-0.3 to 30	V
Operating junction temperature rang	$T_J$	-40 to + 150	°C
Operating ambient temperature rang	$T_{OPA}$	-40 to +85	°C
Storage temperature rang	$T_{STG}$	-65 to +150	°C
Lead temperature (Soldering 5 sec)	$T_{LEAD}$	260	°C
Power dissipation @ $T_A=25$ °C	$P_D$	0.4	W
Thermal resistance junction to ambient (Note 2)	$\theta_{JA}$	160	°C/W
ESD rating, Human body mode (Note 3)	$V_{ESD}$	2	kV

## RECOMMENDED OPERATING CONDITIONS (Note 4)

Parameter	Symbol	Operation Conditions	Unit
Supply Voltage	$V_{DD}$	20	V
Junction Temperature Range	$T_J$	-20 to +125	°C
Ambient Temperature Range	$T_A$	-20 to +85	°C

**Note 1:** Stresses listed as the above "Absolute Maximum Ratings" may cause permanent damage to the device. These are for stress ratings. Functional operation of the device at these or any other conditions beyond those indicated in the operational sections of the specifications is not implied. Exposure to absolute maximum rating conditions for extended periods may remain possibility to affect device reliability.

**Note 2:** Thermal Resistance is specified with the component mounted on a low effective thermal conductivity test board in free air at  $T_A=25$ °C.

**Note 3:** Devices are ESD sensitive. Handling precaution recommended.

**Note 4:** The device is not guaranteed to function outside its operating conditions.

# AT7381

Universal High Brightness LED Driver (patented)



Immense Advance Tech.

## BLOCK DIAGRAM

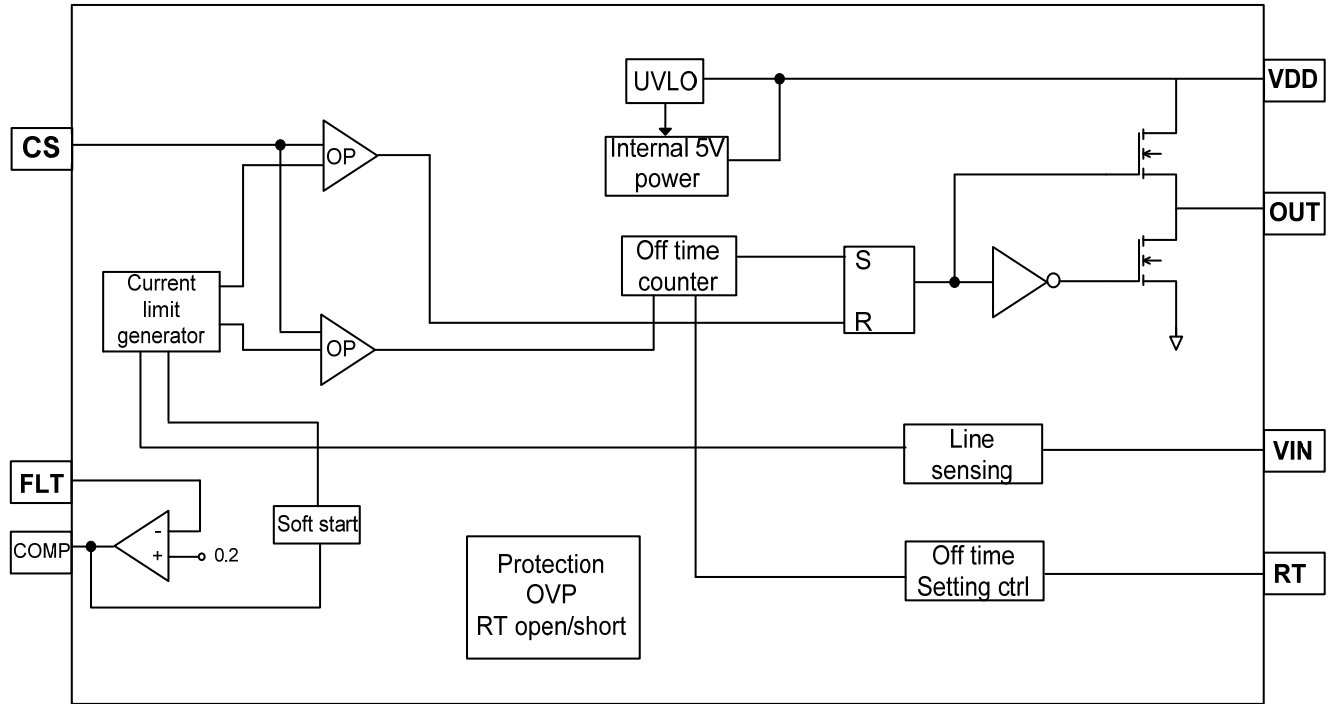

Figure 3

# AT7381

Universal High Brightness LED Driver (patented)



Immense Advance Tech.

## ELECTRICAL CHARACTERISTICS

T<sub>A</sub> = 25°C, unless otherwise specified.

Parameter	Symbol	Condition	Min	Typ	Max	Unit
<b>VDD SECTION</b>						
Start-up Threshold	V <sub>DD(ST)</sub>		17	18	19	V
Under Voltage Lockout Threshold	V <sub>DD(UVLO)</sub>		7.5	8.5	9.5	V
Over Voltage Protection	V <sub>OVP</sub>		27	28	29	V
Start-up Current	I <sub>INST</sub>	V <sub>DD(ST)</sub> - 1V	42	60	78	uA
Operating Current	I <sub>DDQ</sub>		560	800	1040	uA
<b>CURRENT LIMIT SECTION</b>						
Maximum Current Sense Voltage	V <sub>CSPK</sub>		0.67	0.7	0.74	V
Propagation Delay	T <sub>DLY</sub>			70		ns
<b>OUTPUT CURRENT INTEGRATION</b>						
Reference Voltage	V <sub>IREF</sub>			0.2		V
<b>ERROR AMPLIFIER SECTION</b>						
Transconductance	G <sub>M</sub>		84	120	156	uS
Maximum Sink Current	I <sub>SINK</sub>			53		uA
Maximum Source Current	I <sub>SOURCE</sub>			58		uA
<b>LINE SENSING SECTION</b>						
Source Current	I <sub>SE(VIN)</sub>				375	uA
<b>CONSTANT OFF TIME SECTION</b>						
Regulated Voltage	V <sub>RT</sub>		0.95	1	1.05	V
Off-time Setting Range	T <sub>OFF</sub>	R <sub>RT</sub> = 136K~17KΩ	5.73		40.4	us
Constant Off-Time	T <sub>OFF(LV)</sub>	RT = 50K, 85Vac~150Vac	13.5	15	16.5	us
	T <sub>OFF(HV)</sub>	RT = 50K, 180Vac~300Vac	18.9	21	23.1	us
<b>DRIVER SECTION</b>						
Rising Time	T <sub>RISE</sub>	V <sub>DD</sub> =12V, C <sub>load</sub> =1nF		48		ns
Falling Time	T <sub>FAIL</sub>	V <sub>DD</sub> =12V, C <sub>load</sub> =1nF		31		ns
Clamped Voltage	V <sub>GATE</sub>				19	V

## APPLICATION INFORMATION

### 1. Function Description

The AT7381 is a high performance controller which monitors actual output current. These results AT7381 enable tight line and load regulation. The AT7381 uses constant off-time peak current mode control to control the switching current in the MOSFET.

At Initial, VDD capacitor charged through start-up resistor until it achieves 18V. Then AT7381 turns-on the MOSFET and make its shape of peak current flow input sine wave. This performs high power factor and low total harmonic distortion. The output current flow through a current sensing resistor and feedback to FLT pin. The controller always adjusts the amplitude of current command base on the potential of FLT pin. Once the peak current reaches the current command, controller turns off the MOSFET. The resistor connected at RT pin determines the off-time. At the switching on-time, controller senses and limits the maximum switch current by CS pin. This ensures the current in MOSFET be limited in safe operating area.

The AT7381 built-in output short-circuit and over-voltage protection. While the MOSFET turns off at the off-time, the VDD capacitor can get charge by output voltage, and controller can set output over voltage protection threshold by specified zener diode. If the LED string is open, the output voltage will be boost over the designed level until the VDD arrive to 28V. The AT7381 goes into over-voltage protection and latches the MOSFET. The controller starts up the system again while the VDD falls to 8.5V (UVLO). Therefore, the converter

### Immense Advance Tech.

auto-recovery output while the output open circuit condition removed. In case of output short-circuit condition. The VDD capacitor cannot get charge from output voltage. So, the converter repeats start-up and UVLO. However, the AT7381 provides full protections such as OCP, OVP, gate-voltage clamp and cycle-by-cycle current limit.

### 2. Pin Detail

#### 2-1. CS

MOSFET current sensing, use for cycle by cycle switch peak current control.

$$I_{L(limit)} = \frac{0.7V}{R_4}$$

#### 2-2. GND

GND is the reference node of internal circuit.

#### 2-3. FLT

Actual output current sensing, the signal feedback to error amplifier and compare with the internal reference voltage (0.2V).

$$I_o = \frac{0.2V}{R_2}$$

#### 2-4. COMP

This is the output of the Gm amplifier. Connect with a suitable RC network to ground.

### 2-5. RT

Constant off-time setup.

For low-line, 85Vac to 150Vac:

$$t_{off} = \frac{R_T}{50K\Omega} \times 15\mu s$$

For high-line, 180 to 300Vac:

$$t_{off} = \frac{R_T}{50K\Omega} \times 21\mu s$$

### 2-6. VIN

Sense signal input from the rectified line voltage.

### 2-7. VDD

Power supply for the controller during normal operation. The controller will start up when VDD reaches 18V (typical) and will shut-down when VDD voltage is below 8.5V (typical). A decoupling capacitor should be connected between the VDD and GND pin as close as possible.

### 2-8. OUT

Gate drive for external MOSFET switch.

## 3. Design Flow

The typical application circuit for design flow below please refers to figure 1.

### 3-1. Input Signal Sampling

The AT7381 sense input signal from rectified line voltage. VIN pin in series with a resistor of 1.6M, R7 to system ground. It is need to pay attention to enough voltage rating for resistor.

$$R_7 = 1.6M\Omega$$

### 3-2. Low Pass Filter for Switch and Output Current Sensing

Two R-C low pass filter are must for MOSFET switch current sensing and actual output current sensing. The following is recommend values :

$$R_3 = 4.7K\Omega$$

$$C_4 = 1\mu F$$

$$R_5 = 100\Omega$$

$$C_5 = 100pF$$

### 3-3. Loop Compensation

Place a capacitor of 2.2uF for compensation is recommend.

$$C_6 = 2.2\mu F$$

### 3-4. Output Current Sensing Resistor

The output current can be set up by a current sensing resistor, R2. The resistance is calculated following the equation below.

$$R_2 = \frac{0.2V}{I_o}$$



### 3-5. OVP Threshold Voltage

The AT7381 perform output over voltage protection through VDD pin. Once VDD pin exceed in 28V, AT7381 turns off and latch out the MOSFET switcher. The OVP threshold voltage can be set by the Zener diode, ZD<sub>1</sub>.

$$ZD_1 = OVP - 28V$$

### 3-6. VDD, Supply Current Circuit

At the beginning in start-up, the output voltage is not high enough to charge VDD capacitor. Therefore VDD capacitor have to save enough energy for IC operating bias during start-up. To determine the capacitance, we need to calculate the IC operating current, IDD first.

$$IDD \cong C_{iss} \times 20 \times freq + 1.5mA$$

In general, assume the VDD capacitor need to keep enough energy for 50ms. Then the capacitance can be calculated.

$$C_2 \geq \frac{IDD \times 50ms}{18V - 8.5V} \quad C_3 = 100nF$$

Place the VDD capacitor C<sub>2</sub> and bypass capacitor C<sub>3</sub> as close to IC as possible. Moreover, a current spike filter resistor R11 is suggest (10Ω ~ 22Ω) to place between VDD and C3.

### 3-7. Start-up Resistor

At the initial stage, the VDD capacitor get charge through start-up resistor towards the start-up threshold voltage. The smaller start-up resistor the larger power dissipation. The larger start-up resistor the longer charge time.

$$R_1 \geq \frac{t(charge) \times Vac \sqrt{2}}{(C_2 + C_3) \times 18}$$

### 3-8. Off-Time setting

The duty cycle in buck-boost converter is a function of Vin and Vo.

$$Duty_{(pk)} = \frac{V_O}{Vac \sqrt{2} + V_O}$$

The off-time can be set manually by adjusting the size of an external resistor (RT). The AT7381 automaticall adjusts the off-time with the line voltage (Vac). To calculate the operating off-time and RT, the maximum switching frequency at peak of line cycle must be determined first.

$$toff_H = \frac{1 - Duty_{(pk)}}{freq}$$

$$toff_L = \frac{toff_H}{1.4}$$

$$R_6 = \frac{toff_H}{21\mu s} \times 50K\Omega$$

where :

toff<sub>H</sub> is the off-time at high-line (180Vac to 300Vac),

toff<sub>L</sub> is the off-time at low-line (90Vac to 135Vac),

### 3-9. Power Inductor

Assume a target efficiency to estimate input power and input peak current.

$$P_{in} = \frac{V_O \times I_O}{\eta} \quad I_{in(pk)} = \frac{P_{in}}{Vac} \times \sqrt{2}$$

In buck-boost converter, the average of current flow in MOSFET is equal to the input current. If given a ratio of maximum inductor current ripple to maximum inductor peak current,  $\Delta I_L/I_{L(pk)}$ . Then the inductor peak current can be estimated by the equation:

$$I_{L(pk)} = \frac{2I_{in(pk)}}{\left(2 - \frac{\Delta I_L}{I_{L(pk)}}\right) \times Duty_{(pk)}}$$

The maximum inductor current ripple,  $\Delta I_L$  is :

$$\Delta I_L = I_{L(pk)} \times \frac{\Delta I_L}{I_{L(pk)}}$$

From the basic inductor equation, the inductance is :

$$L = \frac{V_O}{\Delta I_L} \times toff$$

Follow the equations above, the inductance and maximum inductor current can be computed. The magnetic design of the inductor must ensure that there is a sufficient flux density margin to avoid saturation with operating current being applied.

### 3-10. Switch Current Sensing Resistor

The AT7381 sense switch current from CS pin to provide cycle-by-cycle current limit. While

### Immense Advance Tech.

the CS pin goes excess of 700mV, the AT7381 force MOSFET switcher turn off. Design the peak inductor current to 75 percent of switcher current limit is recommend.

$$R_4 = \frac{0.53V}{I_{L(peak)}}$$

$$I_{L(limit)} = \frac{0.7V}{R_4}$$

# AT7381

Universal High Brightness LED Driver (patented)



Immense Advance Tech.

## PACKAGE OUTLINE DIMENSIONS

### SOP-8 PACKAGE OUTLINE DIMENSIONS

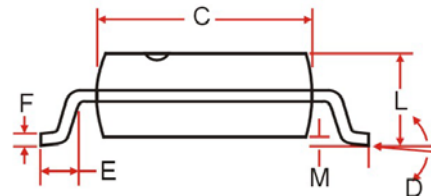
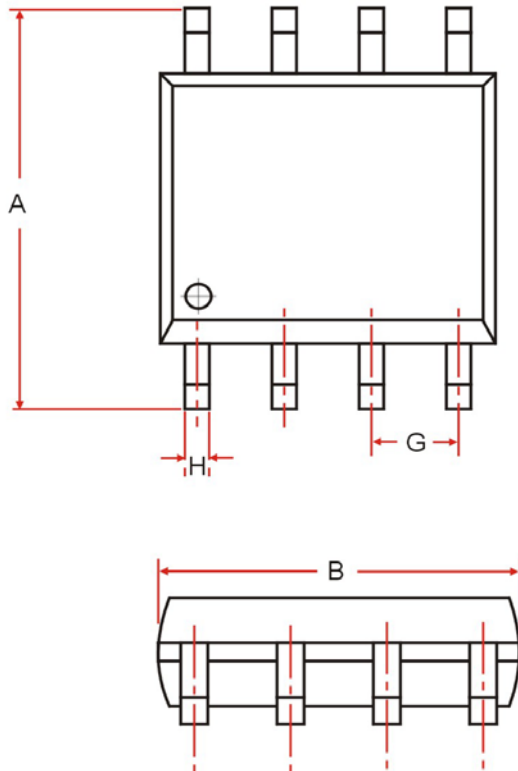

REF.	DIMENSIONS	
	Millimeters	
	Min.	Min.
A	5.80	6.20
B	4.80	5.00
C	3.80	4.00
D	0°	8°
E	0.40	0.90
F	0.15	0.26
M	0	0.25
H	0.31	0.51
L	1.35	1.75
G	1.27 TYP.	

#### Note:

Information provided by IAT is believed to be accurate and reliable. However, we cannot assume responsibility for use of any circuitry other than circuitry entirely embodied in an IAT product; nor for any infringement of patents or other rights of third parties that may result from its use. We reserve the right to change the circuitry and specifications without notice.

Life Support Policy: IAT does not authorize any IAT product for use in life support devices and/or systems. Life support devices or systems are devices or systems which, (I) are intended for surgical implant into the body or (II) support or sustain life, and whose failure to perform, when properly used in accordance with instructions for use provided in the labeling, can be reasonably expected to result in a significant injury to the user. Typical numbers are at 25°C and represent the most likely norm.

#### Note :

Information provided by IAT is believed to be accurate and reliable. However, we cannot assume responsibility for use of any circuitry other than circuitry entirely embodied in an IAT product; nor for any infringement of patents or other rights of third parties that may result from its use. We reserve the right to change the circuitry and specifications without notice.

Life Support Policy: IAT does not authorize any IAT product for use in life support devices and/or systems. Life support devices or systems are devices or systems which, (I) are intended for surgical implant into the body or (II) support or sustain life, and whose failure to perform, when properly used in accordance with instructions for use provided in the labeling, can be reasonably expected to result in a significant injury to the user. Typical numbers are at 25°C and represent the most likely norm.