

**SM72238,SM72240,SM72295,SM72375,SM72442,
SM72480,SM72485**

Application Note 2121 SolarMagic SM3320-BATT-EV Charge Controller

Reference Design



Literature Number: SNOSB76B

SolarMagic™ SM3320-BATT-EV Charge Controller Reference Design

National Semiconductor
Application Note 2121
Florent Boico
February 18, 2011



Introduction

The SM72442 MPPT digital controller and SM72295 photovoltaic full bridge drivers are designed to control high efficiency DC/DC conversion used in photovoltaic applications. This application note will detail the usage of those devices in a battery charging application. The reference design is meant to provide support for a wide variety of implementations, however, unless otherwise noted, this reference design system is shown charging a 12V commercial automotive lead acid battery.

Charging Profile

Figure 1 shows the lead-acid charging profile used in this reference design:

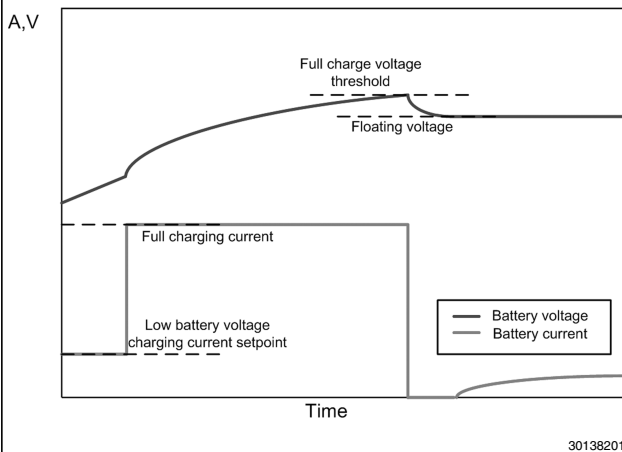

FIGURE 1. Lead-Acid Charging Profile

If the battery voltage is very low, a slow charge current is applied and limited until the voltage rises above a pre-set threshold value V_t . The full charge current is then applied. Once full charge is detected on the voltage of the battery, the system switches to a floating charge and maintains the battery voltage at a fixed threshold. At any time, the system will run in MPPT mode if the available power is lower than the power required to achieve voltage or current regulation.

Features

- 12V Lead Acid Battery
- V_{in} range = 15V to 45V V_{mp} (50V V_{oc})
- Max Input Current: I_{sc} = 11A
- MPPT algorithm for optimized photovoltaic applications
- Up to 9A charging current
- Reverse current protection
- Trickle charge and fast charge mode
- Up to 98% converter efficiency
- 14.2V max charge voltage, 13.5V floating voltage
- Output voltage set-points can be re programmed

Quick Setup Procedure

Step 1: Verify lead-acid battery voltage less than 12V, higher than 10V

Step 2: Connect battery to output terminals as shown in Figure 2

Step 3: Connect Solar panel or Solar Array Simulator to the input terminals as shown in Figure 2.

Step 4: Verify battery charging current up to 9A (Average slightly under 9A)

Step 5: If battery current low, verify input operates at maximum power point voltage as specified by the panel manufacturer

Step 6: verify charging profile follows the profile shown in Figure 1

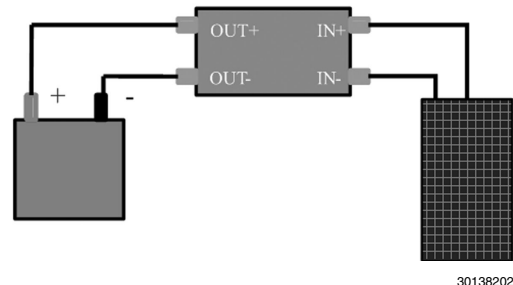

FIGURE 2. System Connection

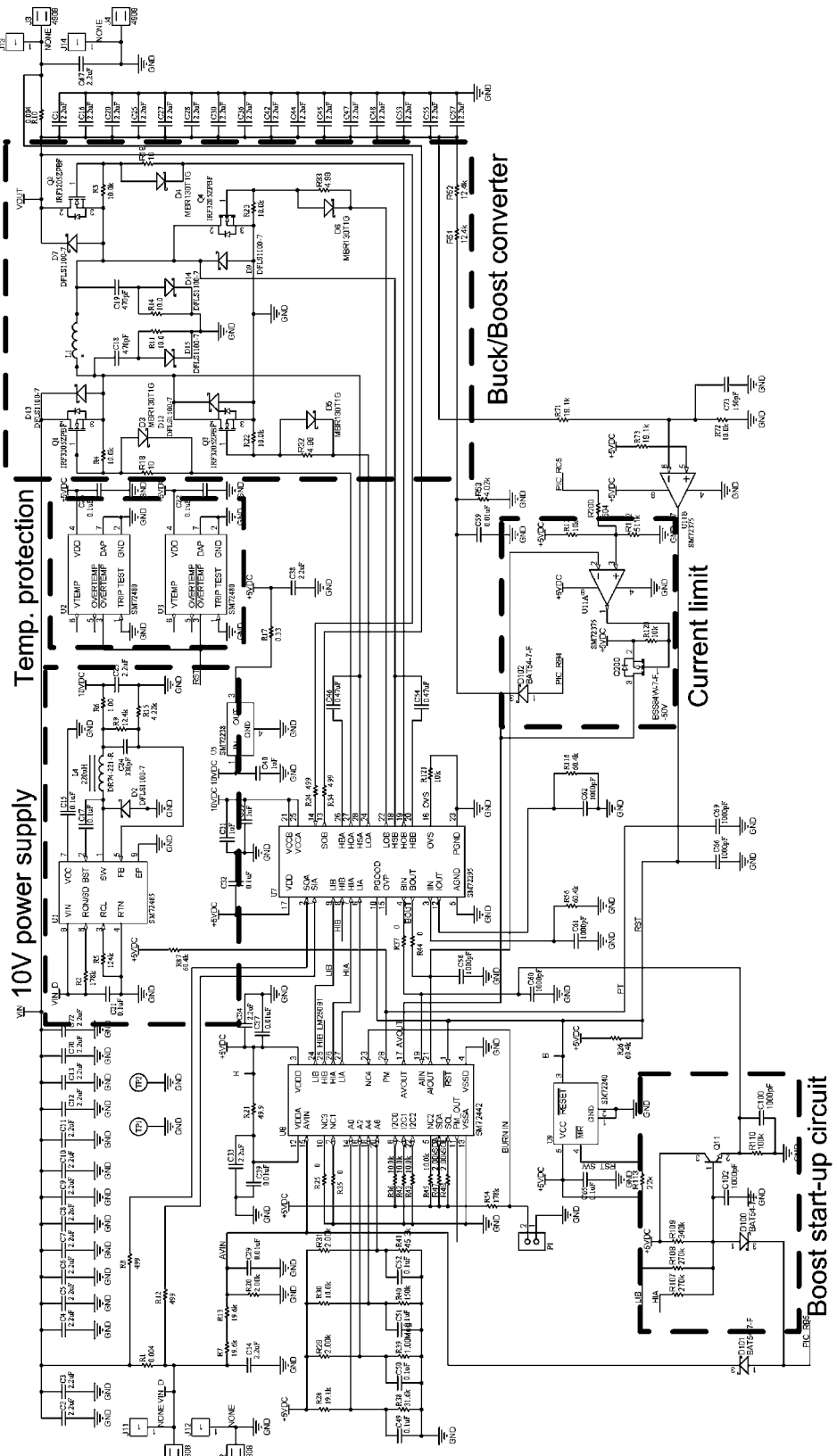
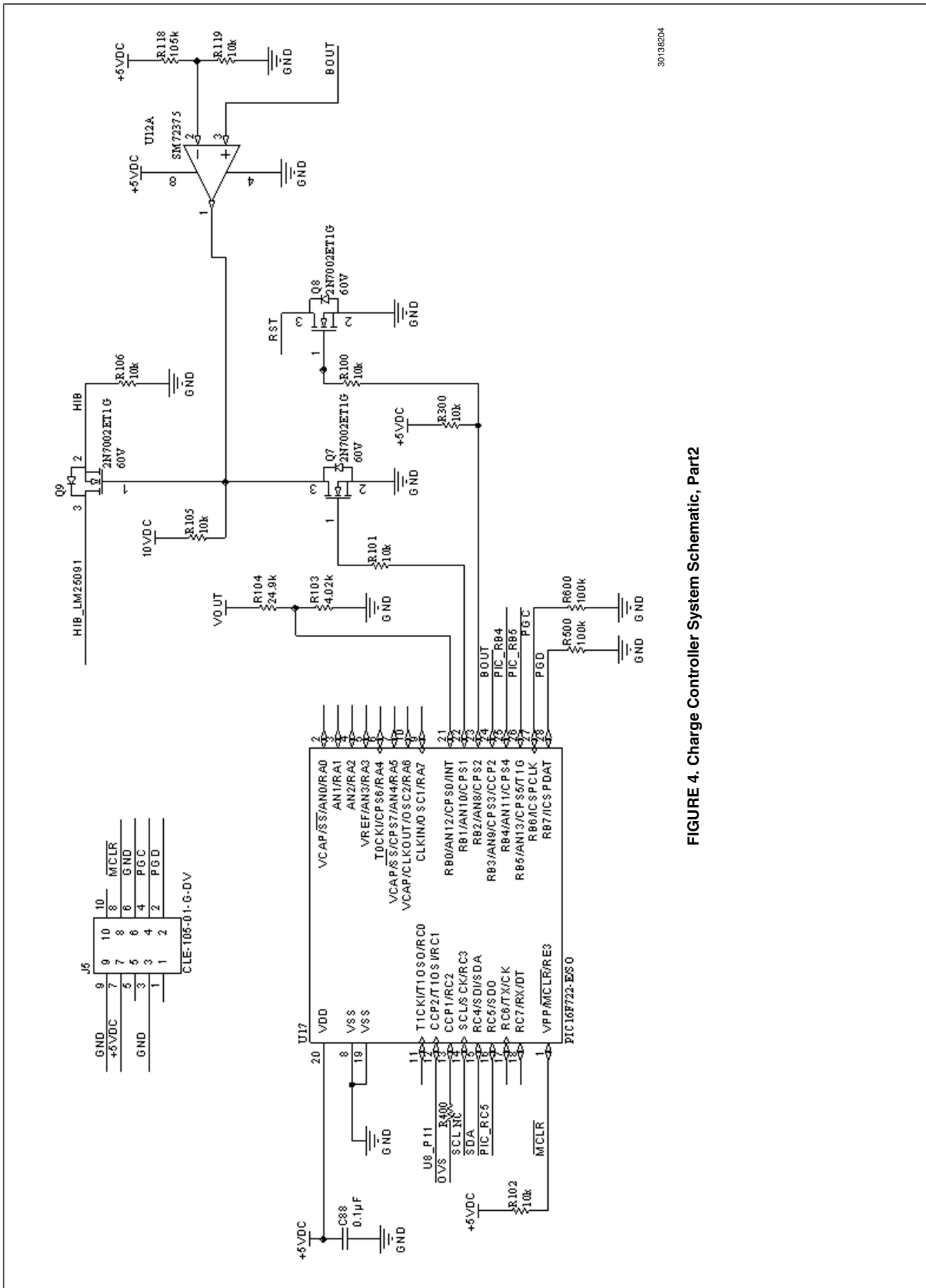

FIGURE 3. Charge Controller System Schematic, Part 1

30138203



30138204

FIGURE 4. Charge Controller System Schematic, Part2

10V Power Supply

The following circuit shown in [Figure 5](#) will provide a 10V power supply rail required to properly bias the SM72295 gate

driver. The system can be configured to work with solar panels up to 100V (with proper components sizing) and down to 12V Vmp.

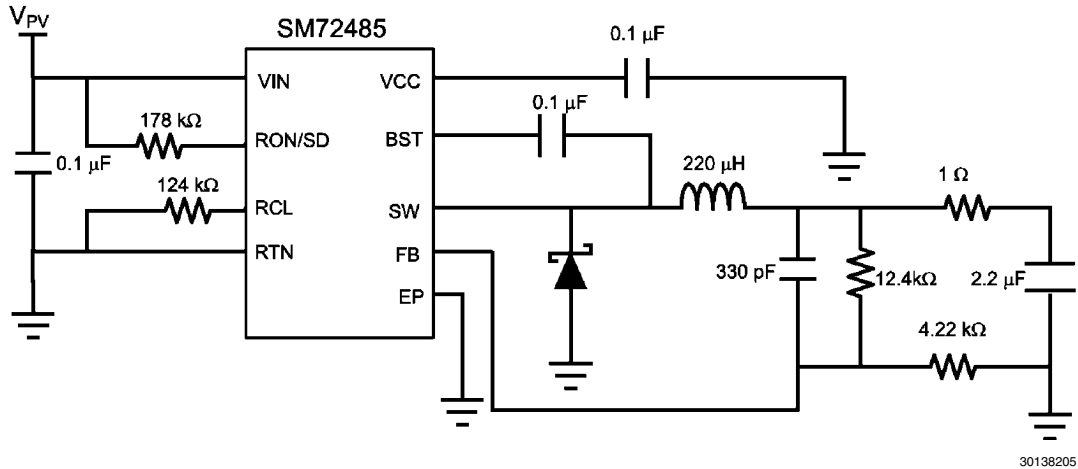

FIGURE 5. 10V Power Supply

DC/DC Converter

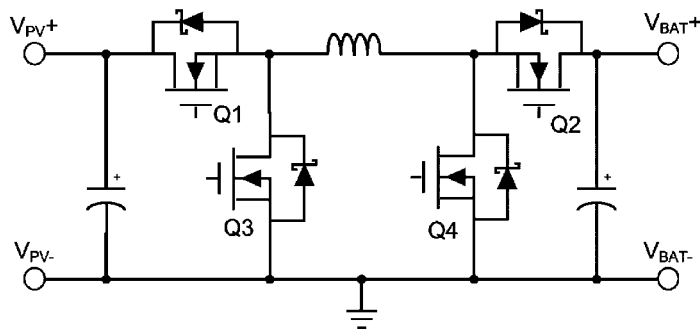

FIGURE 6. DC/DC Converter Stage

The DC/DC converter stage is a step up/step down four switch converter as shown in [Figure 6](#). This stage transfers the power from the PV panel to the load.

C18, R11, and D15 as shown in the system schematic in [Figure 3](#), form a snubber to reduce ripple on the switch node on the “Buck” side of the converter. C19, R14 and D14 form a snubber circuit to reduce ripple on the switch node of the “Boost” side of the converter.

When the circuit operates in Buck mode, the Boost switch node will issue small pulses at a lower frequency in order to recharge the Bootstrap capacitor of Q2. Likewise, in Boost mode, the Buck switch node will pulse to recharge the bootstrap capacitor of Q1.

Specific design guidelines for the DC/DC converter can be found in the Power Design Guidelines Application Note 2124 for power optimizers.

Specific timings related to the switches can be found in the SM72442 and SM72295 datasheets. The waveforms in [Figure 7](#) through [Figure 10](#) are examples of the switching signals of the DC/DC converter stage.

If the system is to be used at elevated power levels causing high temperature increases in MOSFETs Q1, Q2, Q3, and/or Q4, we recommend the use of a proper heatsink for the MOSFETs, especially at higher ambient temperatures. Care must be taken to prevent electrical contact between the drains of the MOSFETs in the process of proper heatsinking.

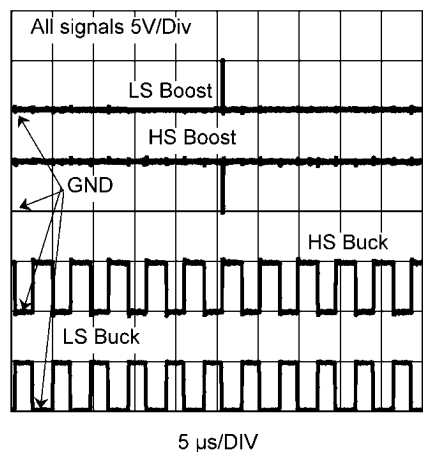

30138207

FIGURE 7. Buck Gate Drive Signals From SM72442

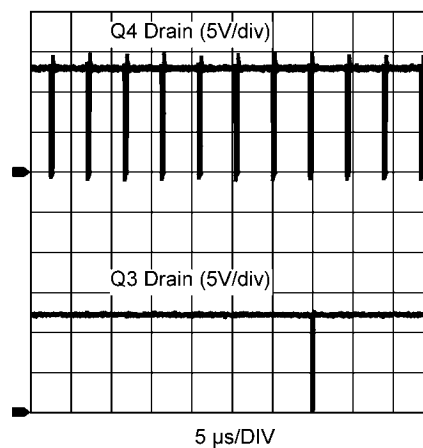

30138210

FIGURE 10. Switch Nodes in Boost Mode

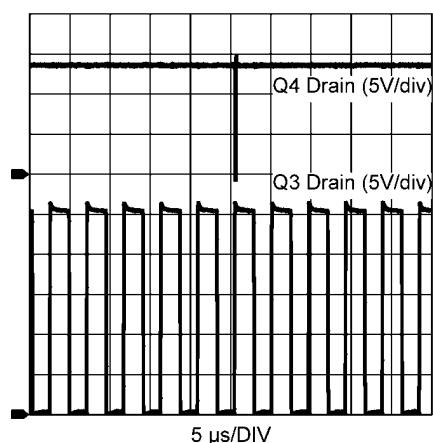

30138208

FIGURE 8. Switch Nodes in Buck Mode

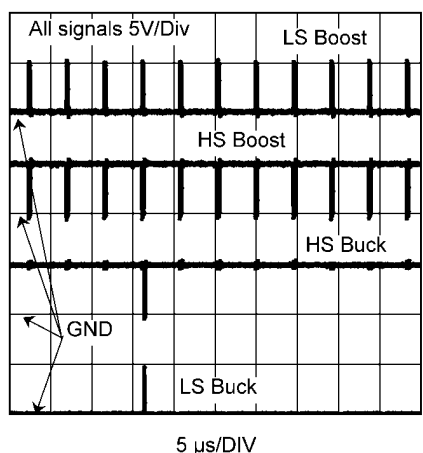

30138209

FIGURE 9. Boost Gate Drive Signals From SM72442

Programmable Modes/Gain Settings

The voltage dividers for the output voltage sensing are set to ensure high resolution of the output voltage while providing a safe voltage (<5V) for the SM72442 and microcontroller.

The default resistor setting in this reference design sets a full scale of 30V.

The programmable modes of the SM72442 used in this design are as follows:

VADC2 = 5V (50% of 4sec in BB)

VADC6 = 5V (startup at 0mA)

VADC0 = 0V. This value provides an initial output voltage limit of 19V. However, this limit will be modified by the microcontroller through I2C before the controller begins supplying the battery

VADC4 = 5V. Current limiting will be done externally so the max current limit can be set at full scale.

Current Sense Gains and Offset

The gain of the current sensing circuit depends on the application. In our system it was set with a gain of 0.44 V/Amps. The gain is set by a pull-down resistor at the output of IOUT (12) and IIN (3) pins of the SM72295 as stated in the datasheet of the device.

Start-Up Circuitry

If the panel voltage is lower than the battery voltage, a start up circuit is required to force the duty cycle high enough to create a flow of current to the battery. Once current is established, the circuit can be turned off to allow MPPT operation to perform.

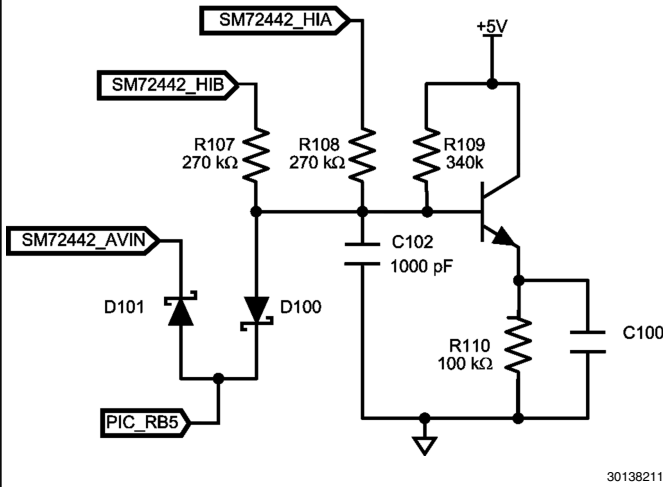

FIGURE 11. Start-Up Boost Circuitry

As long as the start-up circuit is activated, the duty cycle will increase every 1ms up to its maximum value. However, the duty cycle will still be limited by the SM72442's internal output voltage limiter.

The circuit is turned on when the anode of D101 and the cathode of D100 are kept at 5V. It is disabled when that node is set at 0V.

The circuit should be disabled 5ms after current begins to flow into the battery to allow proper MPPT operation.

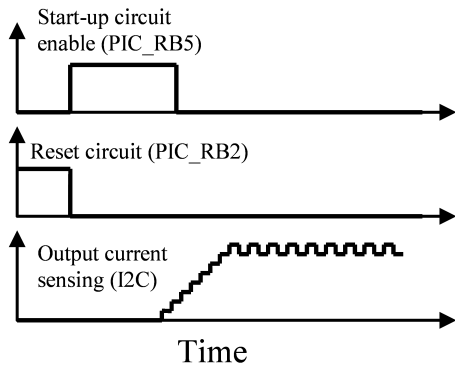

FIGURE 12. Start-up Circuit Timing Diagram

If the current drops to 0 for any reason (no light, reset, etc...) the start-up circuit can be re-engaged according to the timing diagram in Figure 12.

This circuit operates by sensing the average value of the gate voltage on the main buck switch (Q1) and main boost switch

(Q4). This value is fed back to the input current sense of the SM72442. At the same time, a constant 4.4V is set at the input voltage sense pin of the SM72442. This results in the SM72442 measuring a virtual power that increases each time the duty cycle is increased and decreases each time the duty cycle is decreased. The SM72442 will track this virtual power and increase the duty cycle of the converter continuously. When this circuit is de-activated, the real input voltage and current appear at the sensing pins of the SM72442 chip which will then perform regular MPPT operation.

Figure 13 shows the expected waveform if the panel voltage is less than the battery voltage. The panel V_{mp} for this example is 12V @ 3A and the battery voltage is at 25V. Figure 14 showcases the magnified version of the battery current shown in Figure 13.

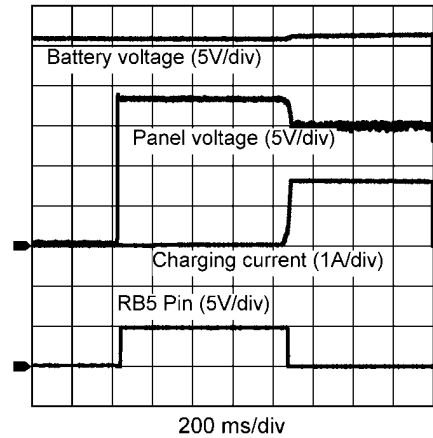

FIGURE 13. Start-up $V_{Panel} < V_{Batt}$

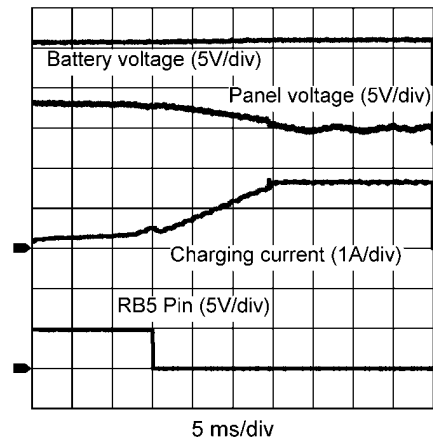

FIGURE 14. Start-up Detail of Battery Current

Note: To highlight the boosting capability of the system and start-up circuit, the board has been re-configured to run with a 24V battery for the experiments shown in Figure 13 and Figure 14.

Output FET Disabling

Q9 keep the topside output FET Q2 from turning on. The power will flow through the parallel diode D7 instead. This prevents the battery from discharging into the PV panels. Q2 can be disabled using the microcontroller or a comparator (U12A) connected to the output current sensing: when current drops below the threshold value, Q2 is disabled. The threshold is set to 1A by default.

Output Current Regulation

Current regulation is enforced by a comparator (U11A). The current setting can be switched from a low current limit to a high current limit with a bit set by the microcontroller. When microcontroller pin RC5 (pin number 16) is set to high impedance, the high current limit is set. When pin RC5 is set to 0V, the low current limit is set.

In this design, the high current limit is set to 9A and the low current limit to 0.5A.

Voltage Regulation

Voltage regulation with the SM72442 is performed internally. The initial output voltage setting is set through pin A0 (0-5V). The output voltage set point can then be changed through the I2C communication interface by setting the register 0x03 bits 20:29 to the required voltage set point and bit 46 to 1.

Figure 15 shows the system performing voltage regulation on the battery at 13.5V.

$$V_{\text{setpoint}} = \frac{\text{Reg3}[29:20]}{1024} \times V_{\text{DDA}} \times \frac{R_{51} + R_{52} + R_{53}}{R_{53}}$$

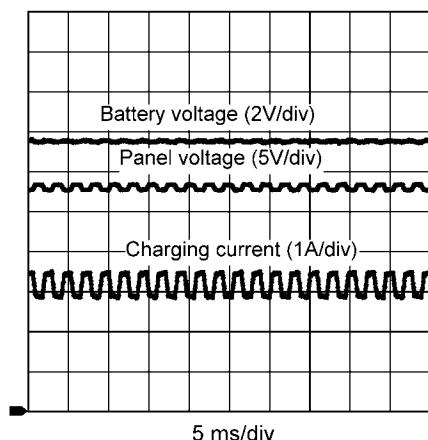

30138215

FIGURE 15. Charging Waveforms During Float

In addition to the voltage regulation, a comparator (U11B) will reset the SM72442 and cause the DC/DC converter to shut-down if the output voltage increases beyond the values set by R71 and R72. When the negative input of the comparator reaches over 5V, the SM72442 controller will be reset. The default value corresponds to 14.6V battery voltage.

MPPT

The SM72442 chip will perform the MPPT function using an implementation of the Perturb and Observe algorithm method. The MPPT algorithm will extract maximum power from the solar panel and deliver it to the battery regardless of the panel's characteristics. Figure 16 and Figure 17 show the effect on the panel voltage as the MPPT algorithm maintains constant power at the panel regardless of the voltage on the battery.

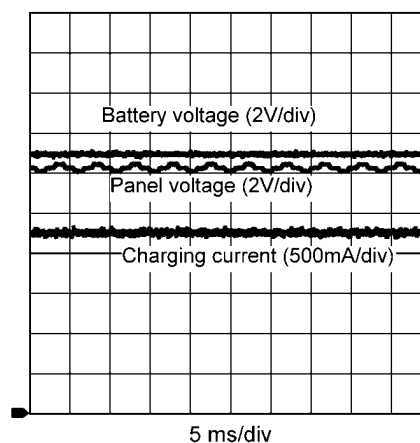

30138216

FIGURE 16. Battery Charging with $V_{\text{Panel}} < V_{\text{Battery}}$ (Boost)

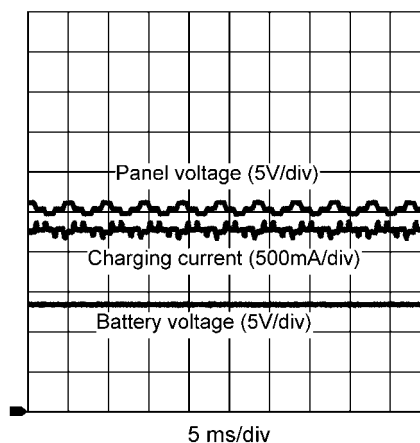

30138217

FIGURE 17. Battery Charging with $V_{\text{Panel}} > V_{\text{Battery}}$ (Buck)

Microcontroller Functions

The charge profile is implemented in the current design using a PIC16F722 microcontroller.

NORMAL OPERATION

The following flowchart in *Figure 18* details the operation of the microcontroller needed to achieve the desired charging pattern.

Modification to this flowchart can easily be done and programmed to include:

- Modified threshold depending on temperature (if battery temperature information available).
- Timer to maintain high voltage threshold for a certain time before switching to floating charge to maximize energy stored in the battery.
- Pulse charging during the float charge period.

The microcontroller is programmed using a 10 pin CLE-105 connector (J5). The connections are:

- 1: NC (Not Connected)
- 2: PGD/ICSPDAT
- 3: GND
- 4: PGC/ICSPCLK
- 5: NC
- 6: GND
- 7: +5Vdc
- 8: MCLR!
- 9: GND
- 10: NC

Refer to the Microchip website for proper programming/debugging of the PIC16F family microcontrollers.

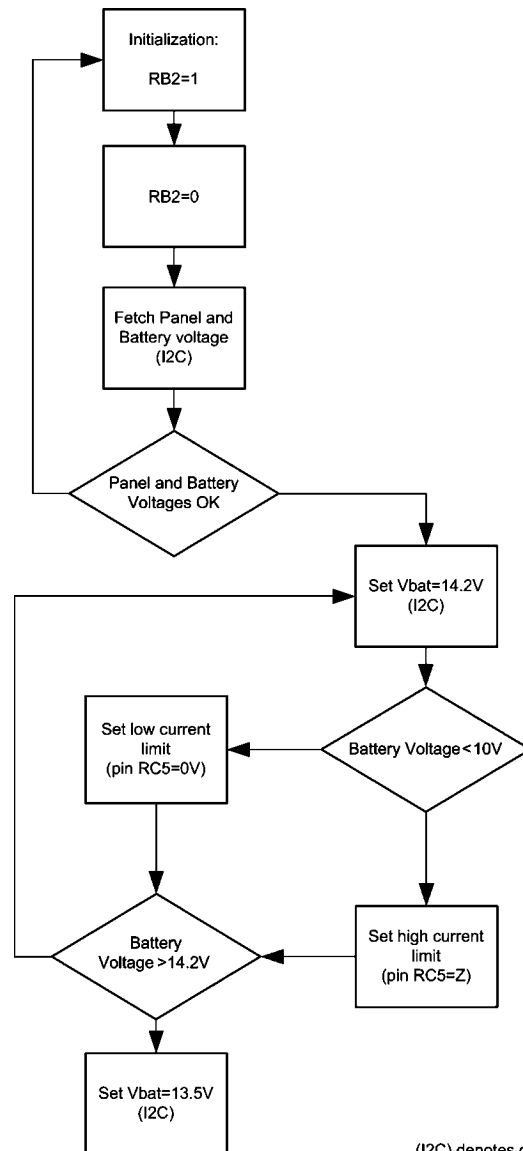

(I2C) denotes operation performed using exchange of data between microcontroller and SM72442 using I2C protocol

30138219

FIGURE 18. Basic Operational Flowchart

START-UP OPERATION

At start-up, the microcontroller needs to assess the PV and battery voltage to verify proper connection and values.

If the values are within the specified range (correct panel and battery voltage), the microcontroller enables the charge by releasing the RESET line of the SM72442 chip. If needed, the start-up circuit is turned on by setting RB5 to '1' (5V) (If the microcontroller used in the application is running below 5V, a level shifting circuit will be necessary).

Once current begins to flow in the battery the start-up circuit can be released.

While the start-up circuit is enabled, the panel current and voltage are not available through I2C. The corresponding registers can be read but will not contain the correct values.

SAFETY FEATURE

The microcontroller is programmed by default to stop charging the battery if the output voltage is above 14.5V or below 8V.

Microcontroller Program Code

The following flowchart in [Figure 19](#) is representative of the code programmed inside the microcontroller:

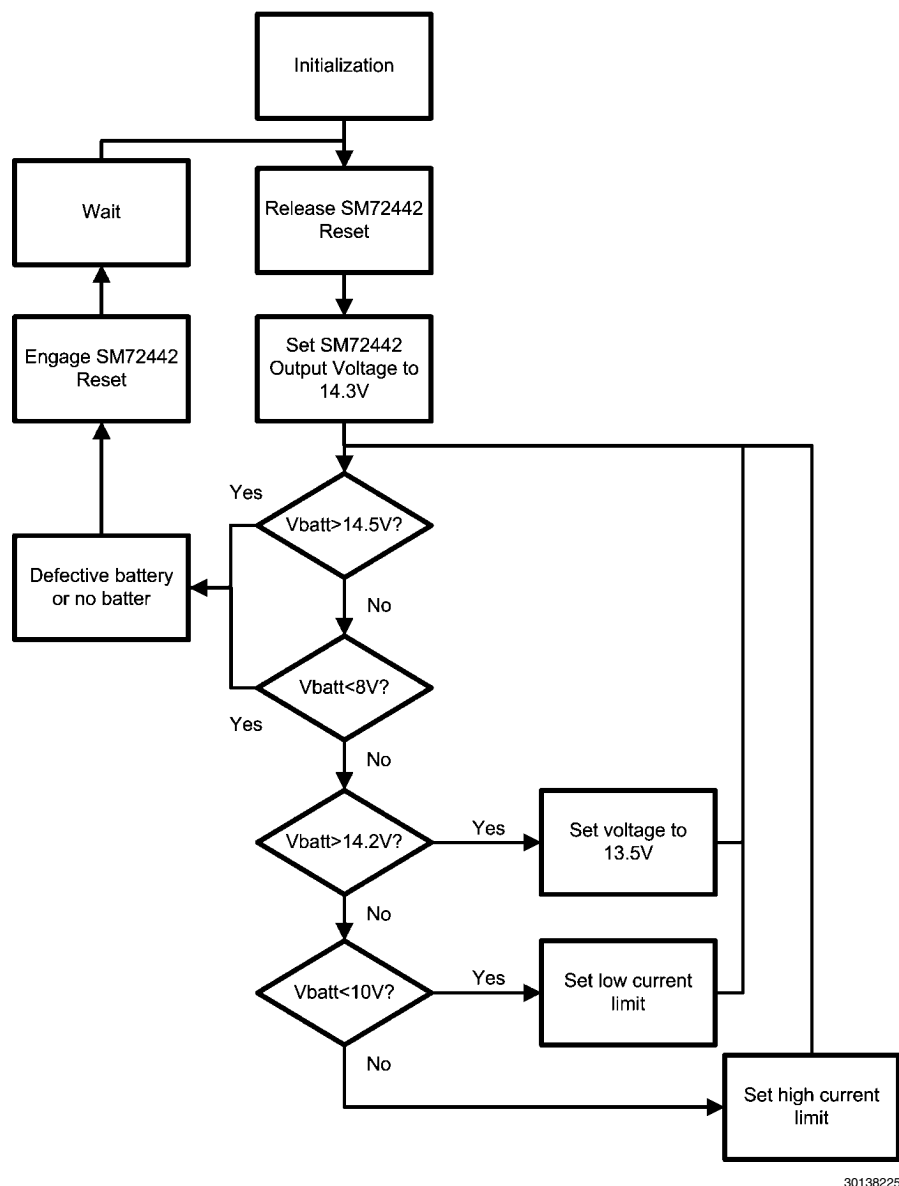

FIGURE 19. Microcontroller Code Flowchart

The `check_lead_acid` function issues a value depending on the state of the battery as detected by the voltage. The main function uses this value to issue the proper action. The other

functions in the program are essentially I2C driver functions and low level port setup functions.

FUNCTION “check_lead_acid()”

This function senses the battery voltage through the microcontroller's A/D converter. The A/D conversion is needed because the current limiting circuit in hardware acts on the voltage sensing line of the SM72442. Therefore, when the system is running in high current mode, the voltage sensed by the SM72442 is not the battery voltage. If the current limitation is not necessary, such as panels with limited power capabilities, the voltage used by the check_lead_acid() function could be changed to the value recovered from the SM72442 through I2C instead of using the microcontroller's ADC.

This function verifies the state of the battery by sensing its voltage and returns an 8 bit number related to the state of the battery:

- 0: No change
- 1: Battery reached the full State Of Charge voltage
- 2: Battery voltage is low
- 3: Battery voltage is too low or battery damaged/ disconnected
- 4: Battery voltage is above the acceptable value: battery damaged or disconnected
- 5: Battery voltage has reached above 13.6V. This is usually due to the lower limit on the duty cycle of the buck converter. When the battery stays in floating charge state for too long, the converter will keep pumping a minimum current into the battery which could result in an increase of the battery voltage beyond the desired floating charge voltage range.
- 6: Battery voltage has returned to an acceptable value

States 5 and 6 correspond to the state of charge of the battery after it has reached its floating charge state value of 13.5V. When “5” is returned by this function, the program will completely cut the charge into the battery (by issuing a reset to the SM72442 via PORTB of the microcontroller). When “6” is returned by this function, the program will re-enable the floating charge into the battery by releasing the reset on the SM72442.

FUNCTION “Main()”

The “Main” function calls the “Init()” function, which simply initializes the variables and the registers. The program then enters an infinite while-loop in which the values of the sensed voltages and current are recovered from the SM72442 through I2C. The function “check_lead_acid()” is called and returns a value based on the voltage of the battery. The “Main” function uses this value to modify the behavior of the system. The following lists the values returned from the “check_lead_acid()” function the corresponding action the “Main” function will take:

- 1 (fully charged battery): The floating charge voltage setpoint will be sent to SM72442 through I2C
- 2 (heavily discharged battery): Trickle charge will be applied
- 3 (battery voltage too low): System shuts down by keeping the SM72442 in reset mode (bit RB2 set)
- 4 (battery voltage too high): System shuts down by keeping the SM72442 in reset mode (bit RB2 set)
- 5 (battery voltage slightly high in floating charge): System shuts down by keeping the SM72442 in reset mode (bit RB2 set) and hysteresis flag set
- 6 (battery voltage dropped below 13V after hysteresis flag set): Re-enable SM72442, hysteresis flag reset

The Main function also resets the watchdog timer once every iteration of the while-loop.

FUNCTION “get_i2c_data”

This function reads the sampled voltage of pin AIIN(19), AVIN(15), AIOU(21) and AVOUT(17) of the SM72442. The data is fetched through the I2C channel. The function updates the global variable “outval” which is an array of unsigned 16 bit integers. The data only occupies 10bits of each integer (full scale=1023).

- outval[0] = input current
- outval[1] = input voltage
- outval[2] = output current
- outval[3] = output voltage

FUNCTION “send_i2c_command(char number)”

Sends an I2C communication string. Each byte sent is stored in the global array “i2c_buffer”. The argument “number” indicates how many bytes from the buffer will be sent (starting with i2c_buffer[0]). Refer to the datasheet and I2C and SM_bus standards documentation for complete protocol information. The main use of this function is to change the voltage limit settings in the SM72442.

FUNCTION “Set_Voutmax()”

This will read the “voutmax” variable set in the main and sends the proper I2C command to the SM72442 to regulate that voltage.

FUNCTION “Check_low_current()”

This function is called by the “Main” function and controls the start-up circuitry to force the duty cycle of the converter up if the current becomes close to 0.

The following [Figure 20](#) summarizes the overall structure of the program: (arrows from the main represent calls to the functions)

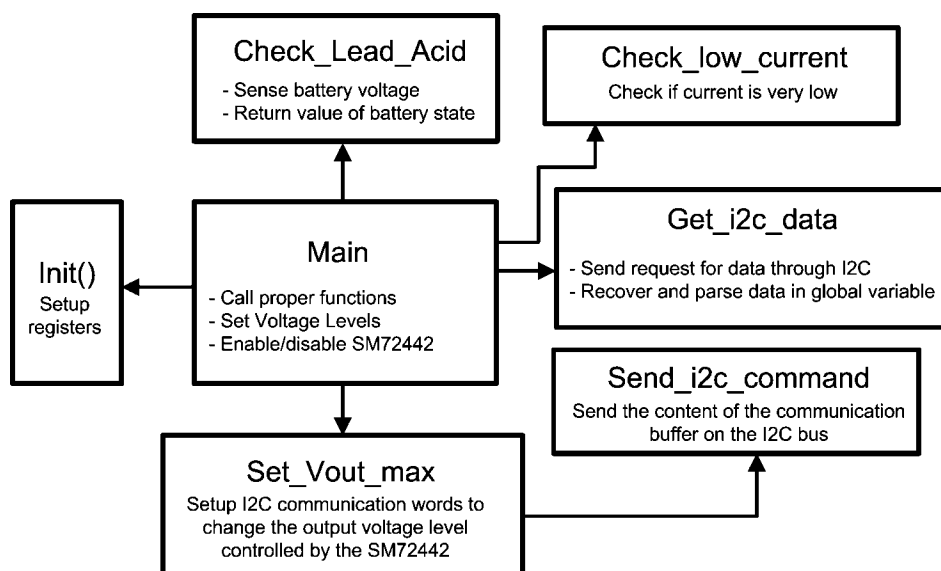

30138226

FIGURE 20. Microcontroller Code Block Diagram

Charging a Li-ion Battery

Although this evaluation board was specifically designed for charging a lead-acid battery, it can be re-configured to accommodate the Li-ion chemistry battery through a combination of hardware and software changes. In order to re-configure the board for Li-ion charging, the following steps need to be done:

1. The voltage sensing resistors R103, R104, R51, R52 and R53 and OVP resistors R71 and R72 need to be changed to the proper values. It is critical for this application that the full scale voltage range for sensing is as close as possible to the voltage of the battery to maximize the resolution of the sensed voltage. The level of the OVP circuit needs to be scaled so that it does not trigger when the battery approaches full SOC but at a voltage slightly higher. R103 and R104 set the voltage at the input of the microcontroller. The voltage at the input of the microcontroller is:

$$V_{A12} = V_{BAT} \times \frac{R_{103}}{R_{103} + R_{104}}$$

R103 and R104 should be chosen so that the maximum expected battery voltage creates a voltage close to 5V to maximize resolution (but less than 5V to avoid saturating the measure).

R51, R52 and R53 are for the voltage measurement of the SM72442 and should be modified in the same way:

$$V_{AVOUT} = V_{BAT} \times \frac{R_{53}}{R_{51} + R_{52} + R_{53}}$$

R21 needs to be set to zero ohm (short).

Once the values are picked, the proper threshold needs to be programmed through I2C. The maximum level (0x3FF) is now $V_{AVOUT} = 5V$ at the input of the SM72442. Finally, the overvoltage protection should be adjusted to:

$$V_{HARD_OVP} = V_{BAT} \times \frac{R_{72}}{R_{71} + R_{72}}$$

The OVP level is set at $V_{HARD_OVP} = 5v$.

2. The proper voltage setpoints and charging curve need to be programmed in the microcontroller. The initial voltage limit is set by R28 and R38. Voltage limit setpoint is AVOUT = A0. Once overridden through I2C, the voltage at A0 is not used anymore. Hence, there is the option of setting the value through resistors R28 and R38 or by programming it from the microcontroller into SM72442 through I2C each time the SM72442 is reset/powered.
3. Proper current limits also need to be set if required by the battery model. The current limit value is set when the voltage at pin 3 of U11A equals the voltage at pin 2. Hence, R111 and R112 will need to be adjusted accordingly.
4. The software needs to be changed to follow the Li-ion charge control profile: battery voltage is set either by hardware as stated above, which requires no action from the software, or it is set from the microcontroller through the I2C interface similar to the Lead Acid battery.
5. Finally, the software needs to include the full State-Of-Charge charge cut-off: When the battery reaches its full voltage and current has dropped below 500mA (can vary depending on battery), charge is cut-off and the battery is considered fully charged (no trickle charge of Li-ion batteries should be done). It is important to remember that current can drop below 500mA during the charge when solar power becomes unavailable (low light intensity). Therefore the charge cut-off needs to be programmed to occur only when the battery voltage is at

the limit AND current has dropped below the required threshold.

Figure 21 shows the typical charging profile for a Li-ion battery.

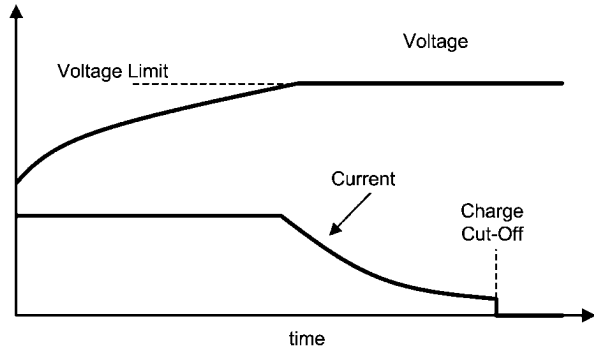

30138224

FIGURE 21. Li-ion Charge Profile

Bill of Materials

Item	Designator	Description	Manufacturer	Part Number	Qty
1	U17	Flash-Based, 8-Bit CMOS Microcontroller, 2K (x14-Bit words) Program Memory, 128 Bytes Data Memory, 25 I/O pins, 28-Pin SOIC, Standard VDD Range, Extended Temperature	Microchip Technology	PIC16F722-E/SS or PIC16F722-I/SS	1
2	C1, C2, C3, C4, C5, C6, C7, C8, C9, C10, C11, C12, C13, C14, C16, C20, C25, C27, C28, C30, C36, C42, C44, C45, C47, C48, C53, C55, C57, C67, C70, C72	Ceramic, X7R, 50V, 10%	MuRata	C3225X7R1H225k/2.50	32
3	C15, C17, C22, C26, C32, C49, C50, C51, C52, C65	Ceramic, X7R, 25V, 10%	MuRata	GRM188R71E104KA01 D	10
4	C18, C19	Ceramic, C0G/NP0, 100V, 5%	AVX	08051A471JAT2A	2
5	C21	Ceramic, X7R, 100V, 10%	Taiyo Yuden	HMK212B7104KG-T	1
6	C23, C33, C34, C38	Ceramic, X7R, 16V, 10%	Taiyo Yuden	EMK212B7225KG-T	4
7	C24	Ceramic, X7R, 50V, 10%	MuRata	GRM188R71H331KA01 D	1
8	C29, C37, C39, C59	Ceramic, X7R, 100V, 20%	AVX	06031C103MAT2A	4
9	C31, C35, C40	Ceramic, X7R, 16V, 10%	Taiyo Yuden	EMK212B7105KG-T	3
10	C46, C54	Ceramic, X7R, 16V, 10%	AVX	0805YC474KAT2A	2
11	C58, C60, C61, C62, C66, C69	Ceramic, C0G/NP0, 100V, 5%	TDK	C1608C0G2A102J	6
12	C73	Ceramic, C0G/NP0, 50V, 5%	TDK	C1608C0G1H151J	1
13	C88	CAP, CERM, 0.1uF, 25V, +/-5%, X7R, 0603	AVX	06033C104JAT2A	1
14	C100, C102	CAP, CERM, 1000pF, 100V, +/-10%, X8R, 0603	TDK	C1608X8R2A102K	2
15	C101	CAP, CERM, 0.1uF, 16V, +/-5%, X7R, 0603	AVX	0603YC104JAT2A	1
16	D2, D7, D9, D12, D13, D14, D15	Vr = 100V, Io = 1A, Vf = 0.77V	Diodes Inc.	DFLS1100-7	7
17	D3, D4, D5, D6	Vr = 30V, Io = 1A, Vf = 0.47V	ON Semiconductor	MBR130T1G	4
18	D100, D101	Vr = 30V, Io = 0.2A, Vf = 0.65V	Diodes Inc.	BAT54-7-F	2
20	J1, J2, J3, J4	PC Quick-Fit 0.250 Tab	Keystone	4908	4
21	J5	CONN RCPT 10POS .8MM DL GOLD SMD	SAMTEC	CLE-105-01-G-DV	1
22	J11, J12, J13, J14	200 mill pad with 165 mill hole	NONE	NONE	4
23	L4	Shielded Drum Core, 0.56A, 0.907 Ohm	Coiltronics	DR74-221-R	1
24	P1	Header, TH, 100mil, 1x2, Tin plated, 230 mil above insulator	Samtec Inc.	TSW-102-07-T-S	1
25	Q1, Q2, Q3, Q4	40A, 53nC, rDS(on) @ 4.5V = 0.018 Ohm	International Rectifier	IRF3205ZPBF	4
26	Q7, Q8, Q9	0.26A, 0.81nC, rDS(on) @ 4.5V = 3	ON Semiconductor	2N7002ET1G	3
27	Q11	Transistor, NPN, 40V, 0.15A, SOT-23	Diodes Inc.	MMBT4401-7-F	1
28	Q200	MOSFET, P-CH, -50V, -130A, SOT-323	Diodes Inc.	BSS84W-7-F	1
29	R1, R10	1%, 2W	Stackpole	CSNL 2 0.004 1% R	2
30	R2, R54	1%, 0.125W	Vishay-Dale	CRCW0805178kFKEA	2

Item	Designator	Description	Manufacturer	Part Number	Qty
31	R3, R4, R22, R23, R30, R36, R42, R43, R45, R72, R100, R101, R102, R105, R106, R111, R119, R120, R121, R300, R400	1%, 0.1W	Vishay-Dale	CRCW060310k0FKEA	21
32	R5	1%, 0.1W	Vishay-Dale	CRCW0603124kFKEA	1
33	R6	1%, 0.125W	Vishay-Dale	CRCW08051R00FNEA	1
34	R7, R13	1%, 0.25W	Vishay-Dale	CRCW120619k6FKEA	2
35	R8, R12, R24, R34	1%, 0.1W	Vishay-Dale	CRCW0603499RFKEA	4
36	R9	1%, 0.1W	Vishay-Dale	CRCW060312k4FKEA	1
37	R11, R14	1%, 1W	Vishay-Dale	CRCW121810R0FKEK	2
38	R15	1%, 0.1W	Vishay-Dale	CRCW06034k22FKEA	1
39	R17	1%, 0.1W	Panasonic	ERJ-3RQFR33V	1
40	R18, R19	RES, 10 ohm, 5%, 0.125W, 0805	Vishay-Dale	CRCW080510R0JNEA	2
41	R20, R29, R31, R47, R48	1%, 0.1W, RES, 2.00k ohm, 1%, 0.1W, 0603	Vishay-Dale	CRCW06032k00FKEA	5
42	R21	1%, 0.1W	Vishay-Dale	CRCW060349R9FKEA	1
43	R25, R35, R37, R44	5%, 0.1W	Vishay-Dale	CRCW06030000Z0EA	4
44	R26, R56, R87, R116	1%, 0.1W	Vishay-Dale	CRCW060360k4FKEA	4
45	R71, R73	1%, 0.1W, RES, 19.1k ohm, 1%, 0.1W, 0603	Vishay-Dale	CRCW060319k1FKEA	3
46	R32, R33	RES, 4.99 ohm, 1%, 0.125W, 0805	Vishay-Dale	CRCW08054R99FNEA	2
47	R38	1%, 0.1W	Vishay-Dale	CRCW060331k6FKEA	1
48	R39	RES, 1.00Meg ohm, 1%, 0.1W, 0603	Vishay-Dale	CRCW06031M00FKEA	1
49	R40	1%, 0.1W	Vishay-Dale	CRCW0603150kFKEA	1
50	R41	RES, 45.3k ohm, 1%, 0.1W, 0603	Vishay-Dale	CRCW060345K3FKEA	1
51	R51, R52	RES, 12.4k ohm, 1%, 0.25W, 1206	Vishay-Dale	CRCW120612K4FKEA	2
52	R53, R103	RES, 4.02k ohm, 1%, 0.1W, 0603	Vishay-Dale	CRCW06034K02FKEA	2
54	R104	RES, 24.9k ohm, 1%, 0.1W, 0603	Vishay-Dale	CRCW060324K9FKEA	1
55	R107, R108	RES, 270k ohm, 1%, 0.1W, 0603	Yageo America	RC0603FR-07270KL	2
56	R109	RES, 340k ohm, 1%, 0.1W, 0603	Yageo America	RC0603FR-07340KL	1
57	R110, R122	RES, 100k ohm, 1%, 0.1W, 0603	Yageo America	RC0603FR-07100KL	2
58	R112	RES, 511k ohm, 1%, 0.1W, 0603	Vishay-Dale	CRCW0603511KFKEA	1
59	R113, R117	RES, 22k ohm, 5%, 0.1W, 0603	Vishay-Dale	CRCW060322K0JNEA	2
61	R118	RES, 105k ohm, 1%, 0.1W, 0603	Vishay-Dale	CRCW0603105KFKEA	1
62	R200	RES, 604 ohm, 1%, 0.1W, 0603	Vishay-Dale	CRCW0603604RFKEA	1
63	R500, R600	RES, 100k ohm, 1%, 0.1W, 0603	Vishay-Dale	CRCW0603100KFKEA	2
64	TP1, TP2	Test Point, SMT, Miniature	Keystone Electronics	5015	2
65	U1	150 mA, 100V Step-Down Switching Regulator	National Semiconductor	SM72485	1
66	U2, U3	1.6V, LLP-6 Factory Preset Temperature Switch and Temperature Sensor	National Semiconductor	SM72480	2
67	U5	Series of Adjustable Micropower Voltage Regulators	National Semiconductor	SM72238	1
68	U7	Driver	National Semiconductor	SM72295	1
69	U8	Digital Controller	National Semiconductor	SM72442	1
70	U9	5-Pin Microprocessor Reset Circuits	National Semiconductor	SM72240	1

Item	Designator	Description	Manufacturer	Part Number	Qty
71	U11, U12	Dual Micro-Power Rail-to-Rail Input CMOS Comparator with Open Drain Output	National Semiconductor	SM72375	2
72	L1	Inductor 2 uH EFD-30 core	PULSE	PA2965-203NL	1

For more National Semiconductor product information and proven design tools, visit the following Web sites at:
www.national.com

Products		Design Support	
Amplifiers	www.national.com/amplifiers	WEBENCH® Tools	www.national.com/webench
Audio	www.national.com/audio	App Notes	www.national.com/appnotes
Clock and Timing	www.national.com/timing	Reference Designs	www.national.com/refdesigns
Data Converters	www.national.com/adc	Samples	www.national.com/samples
Interface	www.national.com/interface	Eval Boards	www.national.com/evalboards
LVDS	www.national.com/lvds	Packaging	www.national.com/packaging
Power Management	www.national.com/power	Green Compliance	www.national.com/quality/green
Switching Regulators	www.national.com/switchers	Distributors	www.national.com/contacts
LDOs	www.national.com/ldo	Quality and Reliability	www.national.com/quality
LED Lighting	www.national.com/led	Feedback/Support	www.national.com/feedback
Voltage References	www.national.com/vref	Design Made Easy	www.national.com/easy
PowerWise® Solutions	www.national.com/powerwise	Applications & Markets	www.national.com/solutions
Serial Digital Interface (SDI)	www.national.com/sdi	Mil/Aero	www.national.com/milaero
Temperature Sensors	www.national.com/tempensors	SolarMagic™	www.national.com/solarmagic
PLL/VCO	www.national.com/wireless	PowerWise® Design University	www.national.com/training

THE CONTENTS OF THIS DOCUMENT ARE PROVIDED IN CONNECTION WITH NATIONAL SEMICONDUCTOR CORPORATION ("NATIONAL") PRODUCTS. NATIONAL MAKES NO REPRESENTATIONS OR WARRANTIES WITH RESPECT TO THE ACCURACY OR COMPLETENESS OF THE CONTENTS OF THIS PUBLICATION AND RESERVES THE RIGHT TO MAKE CHANGES TO SPECIFICATIONS AND PRODUCT DESCRIPTIONS AT ANY TIME WITHOUT NOTICE. NO LICENSE, WHETHER EXPRESS, IMPLIED, ARISING BY ESTOPPEL OR OTHERWISE, TO ANY INTELLECTUAL PROPERTY RIGHTS IS GRANTED BY THIS DOCUMENT.

TESTING AND OTHER QUALITY CONTROLS ARE USED TO THE EXTENT NATIONAL DEEMS NECESSARY TO SUPPORT NATIONAL'S PRODUCT WARRANTY. EXCEPT WHERE MANDATED BY GOVERNMENT REQUIREMENTS, TESTING OF ALL PARAMETERS OF EACH PRODUCT IS NOT NECESSARILY PERFORMED. NATIONAL ASSUMES NO LIABILITY FOR APPLICATIONS ASSISTANCE OR BUYER PRODUCT DESIGN. BUYERS ARE RESPONSIBLE FOR THEIR PRODUCTS AND APPLICATIONS USING NATIONAL COMPONENTS. PRIOR TO USING OR DISTRIBUTING ANY PRODUCTS THAT INCLUDE NATIONAL COMPONENTS, BUYERS SHOULD PROVIDE ADEQUATE DESIGN, TESTING AND OPERATING SAFEGUARDS.

EXCEPT AS PROVIDED IN NATIONAL'S TERMS AND CONDITIONS OF SALE FOR SUCH PRODUCTS, NATIONAL ASSUMES NO LIABILITY WHATSOEVER, AND NATIONAL DISCLAIMS ANY EXPRESS OR IMPLIED WARRANTY RELATING TO THE SALE AND/OR USE OF NATIONAL PRODUCTS INCLUDING LIABILITY OR WARRANTIES RELATING TO FITNESS FOR A PARTICULAR PURPOSE, MERCHANTABILITY, OR INFRINGEMENT OF ANY PATENT, COPYRIGHT OR OTHER INTELLECTUAL PROPERTY RIGHT.

LIFE SUPPORT POLICY

NATIONAL'S PRODUCTS ARE NOT AUTHORIZED FOR USE AS CRITICAL COMPONENTS IN LIFE SUPPORT DEVICES OR SYSTEMS WITHOUT THE EXPRESS PRIOR WRITTEN APPROVAL OF THE CHIEF EXECUTIVE OFFICER AND GENERAL COUNSEL OF NATIONAL SEMICONDUCTOR CORPORATION. As used herein:

Life support devices or systems are devices which (a) are intended for surgical implant into the body, or (b) support or sustain life and whose failure to perform when properly used in accordance with instructions for use provided in the labeling can be reasonably expected to result in a significant injury to the user. A critical component is any component in a life support device or system whose failure to perform can be reasonably expected to cause the failure of the life support device or system or to affect its safety or effectiveness.

National Semiconductor and the National Semiconductor logo are registered trademarks of National Semiconductor Corporation. All other brand or product names may be trademarks or registered trademarks of their respective holders.

Copyright© 2010 National Semiconductor Corporation

For the most current product information visit us at www.national.com



**National Semiconductor
Americas Technical
Support Center**
Email: support@nsc.com
Tel: 1-800-272-9959

**National Semiconductor Europe
Technical Support Center**
Email: europe.support@nsc.com

**National Semiconductor Asia
Pacific Technical Support Center**
Email: ap.support@nsc.com

**National Semiconductor Japan
Technical Support Center**
Email: jpn.feedback@nsc.com

IMPORTANT NOTICE

Texas Instruments Incorporated and its subsidiaries (TI) reserve the right to make corrections, modifications, enhancements, improvements, and other changes to its products and services at any time and to discontinue any product or service without notice. Customers should obtain the latest relevant information before placing orders and should verify that such information is current and complete. All products are sold subject to TI's terms and conditions of sale supplied at the time of order acknowledgment.

TI warrants performance of its hardware products to the specifications applicable at the time of sale in accordance with TI's standard warranty. Testing and other quality control techniques are used to the extent TI deems necessary to support this warranty. Except where mandated by government requirements, testing of all parameters of each product is not necessarily performed.

TI assumes no liability for applications assistance or customer product design. Customers are responsible for their products and applications using TI components. To minimize the risks associated with customer products and applications, customers should provide adequate design and operating safeguards.

TI does not warrant or represent that any license, either express or implied, is granted under any TI patent right, copyright, mask work right, or other TI intellectual property right relating to any combination, machine, or process in which TI products or services are used. Information published by TI regarding third-party products or services does not constitute a license from TI to use such products or services or a warranty or endorsement thereof. Use of such information may require a license from a third party under the patents or other intellectual property of the third party, or a license from TI under the patents or other intellectual property of TI.

Reproduction of TI information in TI data books or data sheets is permissible only if reproduction is without alteration and is accompanied by all associated warranties, conditions, limitations, and notices. Reproduction of this information with alteration is an unfair and deceptive business practice. TI is not responsible or liable for such altered documentation. Information of third parties may be subject to additional restrictions.

Resale of TI products or services with statements different from or beyond the parameters stated by TI for that product or service voids all express and any implied warranties for the associated TI product or service and is an unfair and deceptive business practice. TI is not responsible or liable for any such statements.

TI products are not authorized for use in safety-critical applications (such as life support) where a failure of the TI product would reasonably be expected to cause severe personal injury or death, unless officers of the parties have executed an agreement specifically governing such use. Buyers represent that they have all necessary expertise in the safety and regulatory ramifications of their applications, and acknowledge and agree that they are solely responsible for all legal, regulatory and safety-related requirements concerning their products and any use of TI products in such safety-critical applications, notwithstanding any applications-related information or support that may be provided by TI. Further, Buyers must fully indemnify TI and its representatives against any damages arising out of the use of TI products in such safety-critical applications.

TI products are neither designed nor intended for use in military/aerospace applications or environments unless the TI products are specifically designated by TI as military-grade or "enhanced plastic." Only products designated by TI as military-grade meet military specifications. Buyers acknowledge and agree that any such use of TI products which TI has not designated as military-grade is solely at the Buyer's risk, and that they are solely responsible for compliance with all legal and regulatory requirements in connection with such use.

TI products are neither designed nor intended for use in automotive applications or environments unless the specific TI products are designated by TI as compliant with ISO/TS 16949 requirements. Buyers acknowledge and agree that, if they use any non-designated products in automotive applications, TI will not be responsible for any failure to meet such requirements.

Following are URLs where you can obtain information on other Texas Instruments products and application solutions:

Products

Audio	www.ti.com/audio
Amplifiers	amplifier.ti.com
Data Converters	dataconverter.ti.com
DLP® Products	www.dlp.com
DSP	dsp.ti.com
Clocks and Timers	www.ti.com/clocks
Interface	interface.ti.com
Logic	logic.ti.com
Power Mgmt	power.ti.com
Microcontrollers	microcontroller.ti.com
RFID	www.ti-rfid.com
OMAP Mobile Processors	www.ti.com/omap
Wireless Connectivity	www.ti.com/wirelessconnectivity

Applications

Communications and Telecom	www.ti.com/communications
Computers and Peripherals	www.ti.com/computers
Consumer Electronics	www.ti.com/consumer-apps
Energy and Lighting	www.ti.com/energy
Industrial	www.ti.com/industrial
Medical	www.ti.com/medical
Security	www.ti.com/security
Space, Avionics and Defense	www.ti.com/space-avionics-defense
Transportation and Automotive	www.ti.com/automotive
Video and Imaging	www.ti.com/video

TI E2E Community Home Page

e2e.ti.com

Mailing Address: Texas Instruments, Post Office Box 655303, Dallas, Texas 75265
Copyright © 2011, Texas Instruments Incorporated