

F75198

USB Charger Controller

Release Date: Dec., 2011

Version: V0.11P

F75204 Datasheet Revision History

Version	Date	Page	Revision History
Data Brief	2011/10	-	Data Brief
0.10P	2011/ 11		Up Date AC/DC SPECS
0.11P	2012/ 12		Typo Correction

Please note that all data and specifications are subject to change without notice. All the trade marks of products and companies mentioned in this data sheet belong to their respective owners.

LIFE SUPPORT APPLICATIONS

These products are not designed for use in life support appliances, devices, or systems where malfunction of these products can reasonably be expected to result in personal injury. Customers using or selling these products for use in such applications do so at their own risk and agree to fully indemnify Fintek for any damages resulting from such improper use or sales.



Table of Content

1	General Description	1
2	Feature List	1
3	Application Field	1
4	Pin Configuration	2
5	Pin Description	2
6	Function Description	2
	6.1 F75198 General Function Description	2
	6.1.1 Configuration & Description.....	2
	6.1.2 The Selection of Reference Bias Resistor – SEL.....	3
7	Electrical Characteristics	2
8	Ordering Information	3
9	Top Marking Specification	3
10	Package Spec.	4

1 General Description

The F75198 is the USB Dedicated Charger identification circuit which is so smart to recognized most of mainstream handheld devices. It allows device to draw a current as much as using an original adapter.

The F75198 support most of the USB Battery Charging Specification worldwide, including BC 1.2, Apple® charging spec (for i-Pad & i-Phones) and specs for Samsung Galaxy Tab.

By setting the USB Data pins (D+/D-) to the required voltage levels, then the charging device will recognize the voltage levels, and starts to draw the current to charge. It also equipped with a select pin (SEL) allows users to selection desired charging current for apple devices.

The F75198 is suitable for all charger products using USB interface. It provides enhanced ESD protection up to $\pm 8\text{kV}$ on the DP and DM. With the compact SOT23-5 Package, it require minimum external circuits, which can reduce develop & production cost dramatically.

2 Feature List

- 4.5V~5.5V Single Supply Operation.
- Automatic USB charger Identification Circuit.
- Support Apple® Devices fast charging. (Selectable Apple® 1A / 2A mode)
- Support BC1.2 & YD/T 1591-2009 Charging Spec.
- Support Samsung Galaxy tab Devices Charging.
- $\pm 8\text{kV}$ High ESD Protection On DP/DM.
- Available in SOT23-5 Package.
- Operate in 0°C to $+70^{\circ}\text{C}$ temperature range

3 Application Field

- Computer peripherals.
- In-Car Chargers
- Wall-Adapter / Wall Plugs
- USB Power Plugs (extensions)
- Mobile Power Supply

4 Pin Configuration

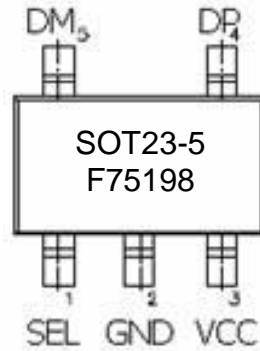

Pin Configuration of F75198

5 Pin Description

- IN - input pin with schmitt trigger.
- OUT - Open-drain output pin
- P -Power.

4.1. Pin Description

F75198	Pin Name	Type	Description
1	SEL	IN	Reference Bias Selection Pin (Internal Pull High) Default : Apple 2A mode Pull-down: Apple 1A mode
2	GND	Ground	Ground
3	VCC	P	Power
4	DP	Analog	USB positive data-channel to external USB device
5	DM	Analog	USB negative data-channel to external USB device

6 Function Description

6.1 F75198 General Function Description

6.1.1 Configuration & Description

The F75198 is a special designed USB charger controller can be applied in any dedicated USB charging solution. The F75198 is able to identify the types of USB device (Apple® devices, BC1.2 USB devices or Samsung Tabs) that is attached to the charging port, and change the configuration of D+/D- data line will emulate dedicated wall adapter instantly. It allows the USB charging port to support both Apple, BC1.2 & Samsung Tab compliant devices.

F75198

The following Figure explains how the F75198 works:

As shown below, F75198 application structure. The F75198 is attached is only controls the D+ / D- signal of the system. It detects the characteristics of the devices attached. Then automatically changes the configuration of D+ / D- according to the type of device which attached to connector.

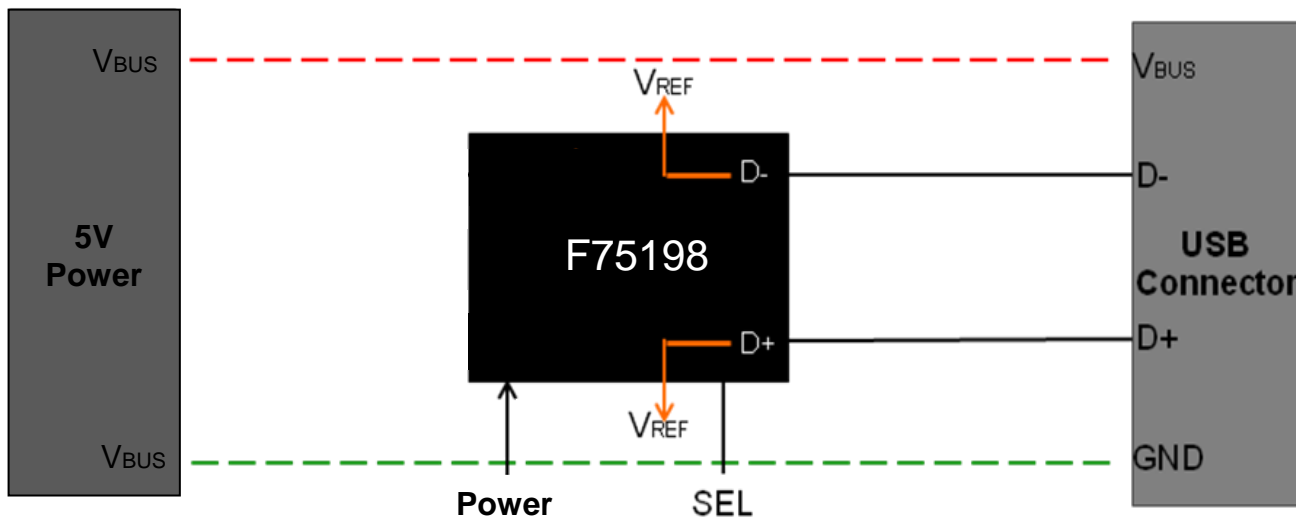

Figure 6.2 Charger Mode (Auto Detect Mode)

Please notice that, the F75198 does not involve any power related operation, it controls only the behavior of the D+ / D- of USB charger port. All the power management & protection mechanism should be finished in the power source block. The F75198 provide only the D+ / D- device recognition.

For best result, use the power source should have the capability to provide at least 5V / 2.1A DC power for each USB Charging port.

6.1.2 The Selection of Reference Bias Resistor – SEL

The F75198 equipped with 2 sets of reference bias resistors for Apple, one allow for the apple device to draw 2A (max) charging current device (Default) and another allows apple device to draw 1A current only. Users can use a single digital input (SEL) to switch between these two reference bias sets.

Table 5.1.2: Truth Table of SEL

SEL	Description
1	Apple 2A mode
0	Apple 1A mode

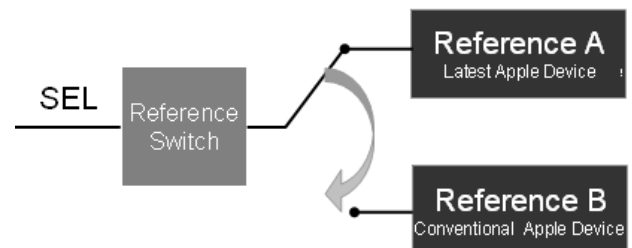

Although the F75198 has a selection pin, which can change the D+ / D- voltage confirmation towards & from Apple® 1A, 2A mode. It's not recommended, However, by use this function as current limit protection, and restrain the charging current of Apple® devices to 1A or less by using this feature.

7 Electrical Characteristics

Absolute Maximum Ratings

PARAMETER	SYMBOL	RATINGS	UNIT
Voltages Referenced to GND	VCC, TDP, TDM, CB, DP, DM, CEN	-0.3 to 6.0	V
Continuous Current into Any Terminal		±30	mA
※ Maximum junction temperature (plastic package)	T_j	+150	°C
※ Maximum storage temperature	T_{STO}	-65 ~ +150	°C
※ Maximum lead temperature (soldering 10s)		+260	°C

Note: If ICs are stressed beyond the limits listed in the “absolute maximum ratings”, they may be permanently destroyed. These are stress ratings only and functional operation of the device at these or any other condition beyond those indicated under “recommended operating conditions” is not implied. Exposure to absolute maximum rated conditions for extended periods may affect device reliability.

Package thermal information

PARAMETER	SYMBOL	SOIC	UNIT
Thermal resistance junction-ambient	R_{th_ja}		°C/W

Recommended Operating Conditions

Supply Voltage, VCC	-----	2.8V~5.5V
Ambient Temperature Range	-----	0°C to 70°C
Junction Temperature Range	-----	-40°C to 125°C

DC and AC electrical characteristics (VCC=5V, TA = 25°C)

PARAMETER	SYMBOL	TEST CONDITIONS	MIN.	TYP.	MAX.	UNIT
POWER SUPPLY						
Operating Power Supply Range	V_{CC}	$V_{CB} > V_{IH}$	4.5		5.5	V
		$V_{CB} = 0V$	4.5		5.5	V
Supply Current	I_{CC}	$V_{CC} = 4.5V$		150	200	uA
		$V_{CC} = 5.5V$		200	250	
ANALOG SWITCH						
Analog Signal Range	V_{DP}, V_{DM}		0		V_{CC}	V
On Resistance of DP/DM short	R_{SHORT}	CB=0, DP=1V, DM=20Kohm		50	70	Ω
Dynamic						
Turn On Time	t_{ON}	V_{TDP} Or $V_{TDM} = 1.5V, R_L = 300\Omega, C_L = 35pF, V_{IH} = V_{CC}, V_{IH} = 0V$		17	40	us

PARAMETER	SYMBOL	TEST CONDITIONS	MIN.	TYP.	MAX.	UNIT
INTERNAL RESISTORS ※						
RP1/RP2 Ratio	$R_{T_{RP}}$		0.854	0.863	0.872	
DP Output Impedance	R_{DP}		17.3		28.6	k Ω
RM1/RM2 Ratio	$R_{T_{RM}}$		1.485	1.5	1.515	
DM Output Impedance	R_{DM}		22.5		37.5	k Ω
ESD Protection						
ESD Protection level (DP and DM only)	V_{ESD}	Air gun contact discharge		± 8		kV
ESD Protection level all other pins	V_{ESD}	Human Body Model		± 2		kV

※ Design Guarantee

8 Ordering Information

Part Number	Package Type	Production Flow
F75198A	SOT23-5	Commercial, 0°C to +70°C

9 Top Marking Specification

The version identification is shown as the bold red characters. Please refer to below for detail:

SOT23-5

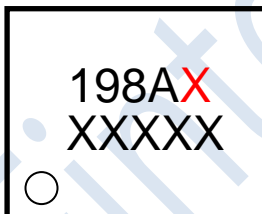

1st Line: Device Name + **IC Version (X)**

2nd Line: Assembly Code (X)+Date code(XXX)+Trace Code(X)

○ : Pin 1 Identifier

10 Package Spec.

SOT23-5 Package

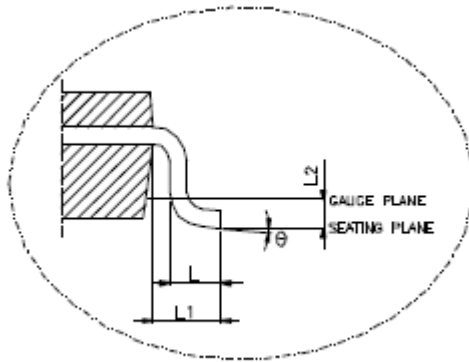
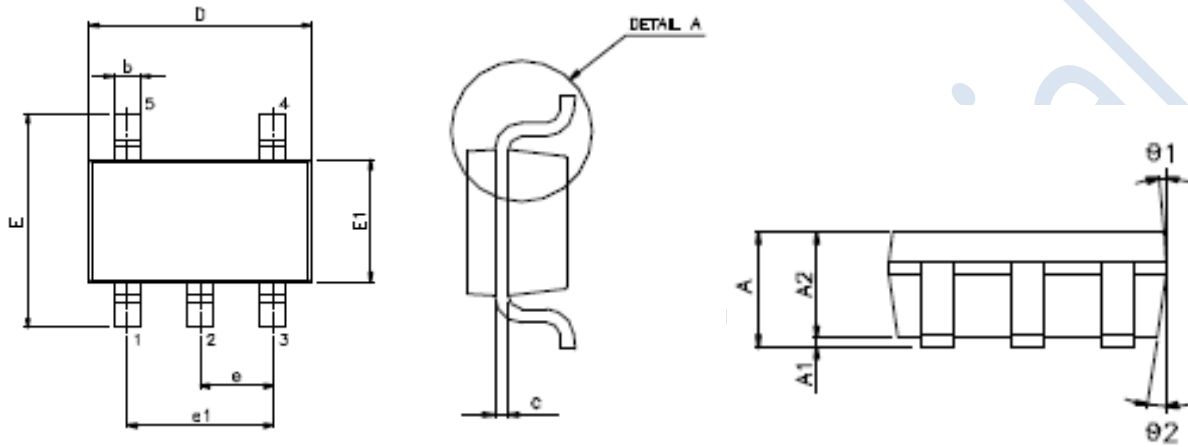

DETAIL A

VARIATION (ALL DIMENSIONS SHOWN IN MM)

SYMBOL	MIN.	NOM.	MAX.
A	1.05	1.20	1.35
A1	0.05	0.10	0.15
A2	1.00	1.10	1.20
b	0.30	—	0.50
c	0.08	—	0.20
D	2.80	2.90	3.00
E	2.60	2.80	3.00
E1	1.50	1.60	1.70
e	0.95 BSC.		
e1	1.90 BSC.		
L	0.30	0.45	0.55
L1	0.60 REF.		
L2	0.25 BSC.		
θ	0°	5°	10°
θ1	3°	5°	7°
θ2	6°	8°	10°

NOTE : 1. JEDEC OUTLINE : MO-178 AA

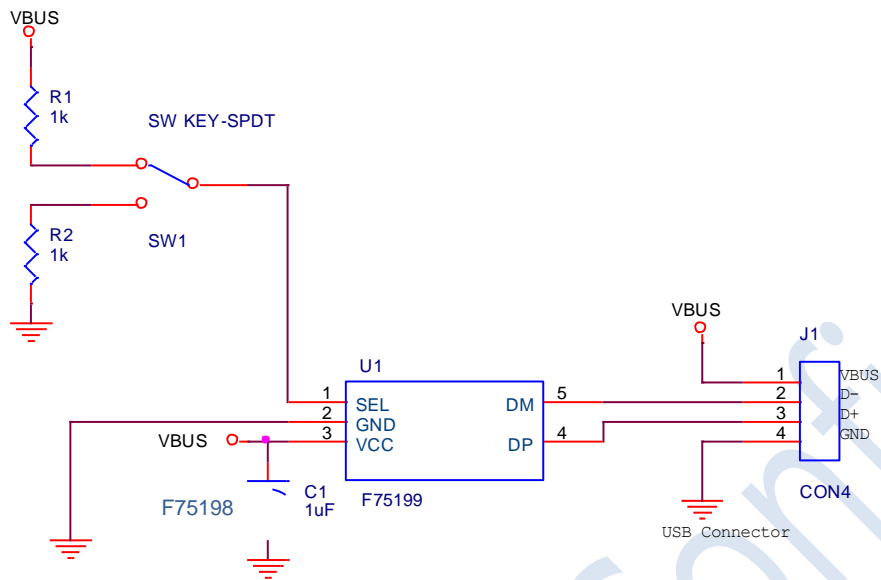
10. Application Circuit



<F75198> Feature Integration Technology inc. tion Technology Inc.

Size	Document Number	Rev
Custom<Doc>		0.1
Date:	Thursday, June 16, 2011	Sheet 1 of 4