

6

5

4

3

2

1

REVISION RECORD			
LTR	ECO NO:	APPROVED:	DATE:

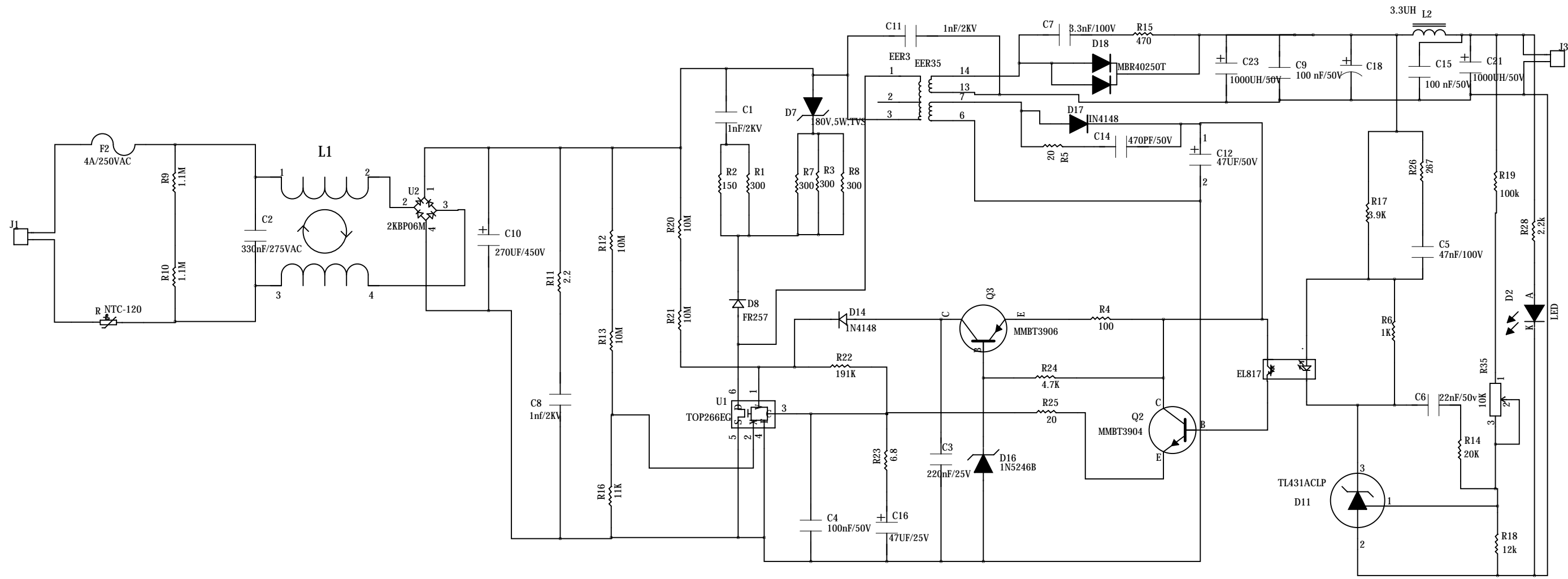

COMPANY: » α Οί 1 α ζ Ø

TITLE: » ù Ó Ú TOP271EG × ö μ Ä 168W ζ α 1 Ø μ ζ Ø

DRAWN: <Drawn By>	DATED: <Drawn Date>
CHECKED: <Checked By>	DATED: <Checked Date>
QUALITY CONTROL: <QC By>	DATED: <QC Date>
RELEASED: <Released By>	DATED: <Release Date>

CODE:	SIZE:	DRAWING NO:	REV:
<Code>	B	20130929vorsion1	
SCALE: <Scale>		SHEET: bf 1	

D

D

C

C

B

B

A

A