

# multiSIM 8

Simulation & Capture

**For Educators**



Multisim™ and Electronics Workbench™

copyright © 1989, 1992-2005 Interactive Image Technologies Ltd. All rights reserved.

Some portions of this product are protected under United States Patent No. 6,560,572.

All other brand or product names are trademarks or registered trademarks of their respective companies or organizations.

MSM8-E-1790 Rev. 1

© 2005 Interactive Image Technologies Ltd. All rights reserved. Published January 2005.

Printed in Canada.

---

# Preface

Congratulations on choosing Multisim 8 from Electronics Workbench. We are confident that it will deliver years of increased productivity and superior designs.

Electronics Workbench is the world's leading supplier of circuit design tools. Our products are used by more customers than those of any other EDA vendor, so we are sure you will be pleased with the value delivered by Multisim 8, and by any other Electronics Workbench products you may select.

## Installation

For complete installation instructions, refer to the “Installing Multisim” chapter of the *Multisim 8 User Guide*.

## Documentation Conventions

When Multisim 8 manuals refer to a toolbar button, an image of the button appears in the left column.

Multisim 8 manuals use the convention **Menu/Item** to indicate menu commands. For example, “**File/Open**” means choose the **Open** command from the **File** menu.

Multisim 8 manuals use the convention of an arrow (➤) to indicate the start of procedural information.

Multisim 8 manuals use the construction CTRL-KEY and ALT-KEY to indicate when you need to hold down the “Ctrl” or “Alt” key on your keyboard and press another key.

## The Multisim 8 Documentation Set

Documentation consists of the *Multisim 8 User Guide*, the *Multisim 8 for Educators* guide, the *Component Reference Guide* and online help. All Multisim 8 Education edition users receive PDF versions of the *Multisim 8 User Guide*, the *Multisim 8 for Educators* guide and the *Component Reference Guide*.

---

## User Guide

The *User Guide* describes Multisim 8 and its many functions in detail. It is organized based on the stages of circuit design, and explains all aspects of using Multisim 8, in detail. It also contains a tutorial that will introduce you to Multisim's many features.

## Multisim 8 for Educators

The *Multisim 8 for Educators* guide describes functions that are specific to the Education edition of Multisim 8.

## Online Help

Multisim offers a full helpfile system to support your use of the product.

Choose **Help/Multisim Help** to display the helpfile that explains the Multisim program in detail, or choose **Help/Component Reference** to display the helpfile that contains details on the components families provided with Multisim. Both are standard Windows helpfiles, offering a table of contents and index.

In addition, you can display context-sensitive help by pressing F1 from any command or window, or by clicking the **Help** button on any dialog box that offers it.

## Adobe PDF Files

The *Multisim 8 User Guide*, *Multisim 8 for Educators* and the *Component Reference Guide* are provided on the documentation CD as Adobe PDF files. To open PDF files, you will need Adobe's free Acrobat Reader program, available for download at [www.adobe.com](http://www.adobe.com).

## License Agreement

Before installing and using the software contained in this package, please read "License Agreement" in the "Installing Multisim" chapter of the *Multisim 8 User Guide* carefully. By installing and using the software, you are agreeing to be bound by the terms of this license. If you do not agree to the terms of this license, simply return the unused software within ten days to the place where you obtained it and your money will be refunded.

# Table of Contents

## 1. Educators' Guide

|         |                                     |      |
|---------|-------------------------------------|------|
| 1.1     | Circuit Creator's Name              | 1-1  |
| 1.2     | Assigning Faults to Components      | 1-2  |
| 1.2.1   | Setting a Placed Component's Faults | 1-2  |
| 1.2.2   | Using the Auto Fault Option         | 1-3  |
| 1.3     | Using Restrictions                  | 1-4  |
| 1.3.1   | Setting Global Restrictions         | 1-4  |
| 1.3.1.1 | General Global Restrictions         | 1-5  |
| 1.3.1.2 | Simplified Version                  | 1-6  |
| 1.3.1.3 | Global Analyses Restrictions        | 1-8  |
| 1.3.2   | Setting Circuit Restrictions        | 1-9  |
| 1.3.3   | Setting Passwords for Restrictions  | 1-12 |
| 1.4     | Link to Education Resources         | 1-13 |

## 2. Breadboarding

|       |                                      |      |
|-------|--------------------------------------|------|
| 2.1   | Breadboarding Overview               | 2-2  |
| 2.2   | Setting up the Breadboard            | 2-2  |
| 2.2.1 | Breadboard Settings                  | 2-2  |
| 2.2.2 | 3D Options                           | 2-3  |
| 2.3   | Placing Components on the Breadboard | 2-4  |
| 2.4   | Wiring Placed Components             | 2-8  |
| 2.4.1 | Placing a Jumper                     | 2-8  |
| 2.4.2 | Changing Jumper Wire Color           | 2-9  |
| 2.5   | Viewing Component Information        | 2-10 |
| 2.6   | Manipulating the Breadboard View     | 2-12 |
| 2.7   | Breadboard Netlist dialog box        | 2-13 |
| 2.8   | DRC and Connectivity Check           | 2-14 |

---

## 3. Ladder Diagrams

|       |                                 |      |
|-------|---------------------------------|------|
| 3.1   | Overview .....                  | 3-1  |
| 3.2   | Creating a Ladder Diagram ..... | 3-2  |
| 3.3   | AND Rungs and OR Rungs .....    | 3-5  |
| 3.4   | Sample Circuits .....           | 3-7  |
| 3.4.1 | Holding Tank .....              | 3-7  |
| 3.4.2 | Conveyor Belt .....             | 3-12 |
| 3.4.3 | Traffic Light .....             | 3-17 |

## Appendix A - Education Edition Parts

|        |  |      |
|--------|--|------|
| A.1    | Rated Virtual Components .....         | A-1  |
| A.1.1  | Rated 555 Timer .....                  | A-2  |
| A.1.2  | Rated BJTs .....                       | A-3  |
| A.1.3  | Rated Capacitors .....                 | A-4  |
| A.1.4  | Rated Diodes .....                     | A-4  |
| A.1.5  | Rated Fuses .....                      | A-5  |
| A.1.6  | Rated Inductors .....                  | A-6  |
| A.1.7  | Rated LEDs .....                       | A-6  |
| A.1.8  | Rated DC Motor .....                   | A-7  |
| A.1.9  | Rated Relay .....                      | A-8  |
| A.1.10 | Rated Opamp .....                      | A-9  |
| A.1.11 | Rated Photodiode .....                 | A-10 |
| A.1.12 | Rated Phototransistor .....            | A-10 |
| A.1.13 | Rated Potentiometer .....              | A-11 |
| A.1.14 | Rated Pullup .....                     | A-12 |
| A.1.15 | Rated Resistor .....                   | A-12 |
| A.1.16 | Rated Transformers .....               | A-13 |
| A.1.17 | Rated Variable Capacitor .....         | A-14 |
| A.1.18 | Rated Variable Inductor .....          | A-15 |
| A.1.19 | Rated Virtual Components Toolbar ..... | A-16 |
| A.2    | 3D Virtual Parts .....                 | A-16 |
| A.2.1  | 3D 555 Timer .....                     | A-17 |
| A.2.2  | 3D BJT .....                           | A-17 |
| A.2.3  | 3D Capacitors .....                    | A-18 |
| A.2.4  | 3D 74LS160N Counter .....              | A-18 |
| A.2.5  | 3D Diode .....                         | A-19 |

---

|         |                       |      |
|---------|-----------------------|------|
| A.2.6   | 3D Inductor           | A-19 |
| A.2.7   | 3D LED                | A-19 |
| A.2.8   | 3D MOSFET             | A-20 |
| A.2.9   | 3D DC Motor           | A-20 |
| A.2.10  | 3D Opamp              | A-20 |
| A.2.11  | 3D Potentiometer      | A-21 |
| A.2.12  | 3D AND Gate           | A-21 |
| A.2.13  | 3D Resistor           | A-22 |
| A.2.14  | 3D Shift Register     | A-22 |
| A.2.15  | 3D Switch             | A-22 |
| A.2.16  | 3D Components toolbar | A-23 |
| A.3     | Ladder Diagram Parts  | A-23 |
| A.3.1   | Ladder Rungs          | A-23 |
| A.3.1.1 | L1 and L2             | A-23 |
| A.3.2   | Ladder I/O Modules    | A-24 |
| A.3.2.1 | Input Module          | A-24 |
| A.3.2.2 | Output Module         | A-24 |
| A.3.3   | Ladder Relay Coils    | A-25 |
| A.3.3.1 | Relay Coil            | A-25 |
| A.3.3.2 | Negated Relay Coil    | A-25 |
| A.3.3.3 | Set Coil              | A-25 |
| A.3.3.4 | Reset Coil            | A-26 |
| A.3.3.5 | Pulsed Relay Coil     | A-26 |
| A.3.4   | Ladder Contacts       | A-26 |
| A.3.4.1 | Input Contact NC      | A-26 |
| A.3.4.2 | Input Contact NO      | A-27 |
| A.3.4.3 | Relay Contact NC      | A-27 |
| A.3.4.4 | Relay Contact NO      | A-28 |
| A.3.5   | Ladder Counters       | A-28 |
| A.3.5.1 | Count Off             | A-28 |
| A.3.5.2 | Count Off Hold        | A-29 |
| A.3.5.3 | Count Off Reset       | A-29 |
| A.3.5.4 | Count Off Up Down     | A-30 |
| A.3.5.5 | Count On              | A-30 |
| A.3.5.6 | Count On Hold         | A-31 |
| A.3.5.7 | Count On Reset        | A-31 |
| A.3.5.8 | Count On Up Down      | A-32 |
| A.3.6   | Ladder Timers         | A-32 |
| A.3.6.1 | Timer TOFF            | A-32 |
| A.3.6.2 | Timer TON             | A-33 |
| A.3.6.3 | Timer TON Retention   | A-33 |

---

|       |         |  |      |
|-------|---------|--|------|
|       | A.3.6.4 | Timer TON Retention Reset . . . . .      | A-34 |
|       | A.3.6.5 | Timer TON Retention Hold Reset . . . . . | A-34 |
| A.3.7 |         | Ladder Output Coils . . . . .            | A-35 |
|       | A.3.7.1 | Output Coil . . . . .                    | A-35 |
|       | A.3.7.2 | Output Coil Negated . . . . .            | A-35 |
| A.3.8 |         | Ladder Output Devices . . . . .          | A-36 |
|       | A.3.8.1 | Holding Tank . . . . .                   | A-36 |
|       | A.3.8.2 | Conveyor Belt . . . . .                  | A-37 |
|       | A.3.8.3 | Traffic Light . . . . .                  | A-38 |

# Chapter 1

## Educators' Guide

In addition to the many features that have made Multisim a favorite with professional users, there are also a number of education-specific features that are outlined in this guide.

This chapter describes the tools that Multisim offers to let you exercise greater control over the program's interface and functionality when sharing circuits with students, as well as to set certain aspects of a circuit's behavior for instructional purposes. These features include assigning faults to components in a circuit and setting global and circuit restrictions.

Some of the features described in this chapter may not be available in your edition of Multisim 8. Refer to the release notes for a description of the features available in your edition.

The following are described in this chapter.

| <b>Subject</b>                        | <b>Page No.</b> |
|---------------------------------------|-----------------|
| <b>Circuit Creator's Name</b>         | 1-1             |
| <b>Assigning Faults to Components</b> | 1-2             |
| <b>Using Restrictions</b>             | 1-4             |
| <b>Link to Education Resources</b>    | 1-13            |

### 1.1 Circuit Creator's Name

Multisim provides a feature by which the name of the creator of each circuit is stored with that circuit. Educators can take advantage of this feature to identify the student who, for example, created the circuit being submitted as the answer to an assignment (provided that the student uses his/her own copy of the program to create the circuit). The name appears on the Circuit Restrictions dialog box, which you can view as long as no passwords have been set — see “1.3.2 Setting Circuit Restrictions” on page 1-9 for more information.

## 1.2 Assigning Faults to Components

You may want to assign faults to components for instructional purposes, such as troubleshooting exercises. You can manually assign faults to individual components in a circuit or let Multisim randomly assign faults to various components across a circuit.

### 1.2.1 Setting a Placed Component's Faults

You can assign a fault to any terminal of the placed component using the **Fault** tab of that component's properties dialog box.

- To assign a fault to a placed component:
  1. Double-click on the component. The component's properties dialog box appears.
  2. Click the **Fault** tab:

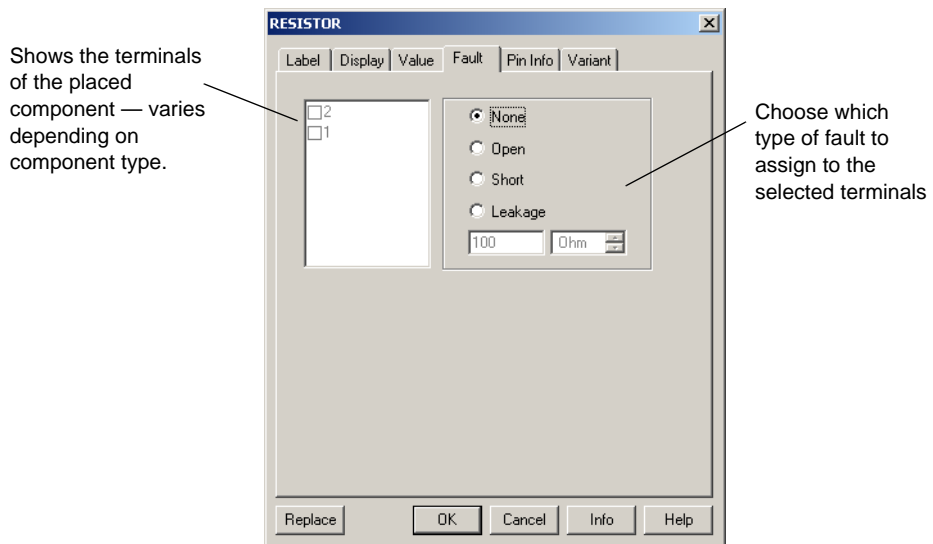

**Note** Refer to the *Multisim 8 User Guide* for information on the other tabs in the above dialog box.

3. Select the terminals to which the fault should apply.

4. Enable the type of fault you want assigned to a terminal. The options are:

| Option  | Description   |
|---------|---|
| None    | No fault.   |
| Open    | Assigns a very high resistance to the terminal, as if the wire leading to the terminals was broken.   |
| Short   | Assigns a very low resistance to the terminal, so the component has no measurable affect on the circuit.  |
| Leakage | Assigns the resistance value specified in the fields below the option, in parallel with the selected terminals. This causes the current to leak past the terminals instead of going through them. |

5. To cancel your changes, click **Cancel**. To save your changes, click **OK**.

## 1.2.2 Using the Auto Fault Option

**Note** This function is hidden when the simplified version option is selected. For details, see “1.3.1.2 Simplified Version” on page 1-6.

When you use the **Auto Fault** option, you specify the number of any type of fault or, optionally, the number of faults per different type of fault, that you want Multisim to assign to placed components in the circuit.

- To use the auto fault option:

1. Choose **Simulate/Auto Fault Option**. The **Auto Fault** dialog box appears:

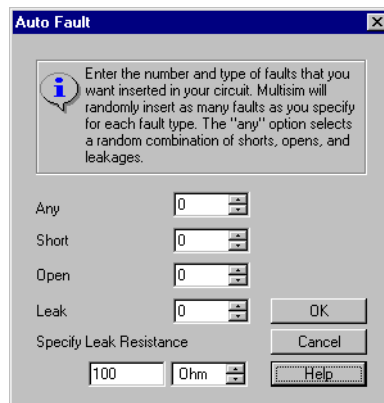

**Note** The **Auto Fault** option is disabled until a component is placed on the workspace.

2. Use the up/down arrow keys or enter numerical values directly in the **Short**, **Open**, and **Leak** fields, or enter a numerical value in the **Any** field to let Multisim randomly select the type of faults to assign (in the quantity entered).
3. If you specify a number of leaks, enter a number and unit of measurement in the **Specify Leak Resistance** fields.
4. Click **OK** to apply the faults, or **Cancel** to cancel, and return to the circuit window.

## 1.3 Using Restrictions

Restrictions are useful in a number of ways:

- when you are designing circuits for demonstration purposes and want to limit the functionality available to students
- when you are sharing circuits with students and want:
  - to prevent them from being able to edit the circuit in any way
  - to limit the types of modifications they can make to a circuit
  - to limit the types of analyses they can perform on it
  - to limit the information they can see about certain parts of the circuit (for example, the value of a resistor you want them to calculate).

You can set global-level restrictions, which become default Multisim settings, or circuit-level restrictions, which affect only specific circuits.

To ensure that only you can set or modify restrictions, you use passwords which can protect both global and circuit restrictions. It is important that you set passwords immediately when using restrictions that you want to keep secure against any modification by students. The password for global restrictions is encrypted and stored in the Multisim program file. The password for circuit restrictions (for restricting only a particular circuit) is encrypted and stored in the circuit file.

### 1.3.1 Setting Global Restrictions

Use global restrictions to set the basic level of functionality of Multisim available to students in all circuits with which they will work. You can select a default path where circuits are to be saved, hide databases and the In Use List, and determine whether students may edit components or place instruments.

You can also hide complicated instruments and analysis options from the menus by using the simplified version. See “1.3.1.2 Simplified Version” on page 1-6.

**Note** Global restrictions are overridden by circuit restrictions if the circuit restrictions are saved with the circuit. See “1.3.2 Setting Circuit Restrictions” on page 1-9 for information.

### 1.3.1.1 General Global Restrictions

➤ To set general global restrictions:

1. Choose **Options/Global restrictions**. The **Password** dialog box appears.

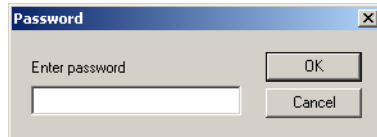

**Note** The above dialog also appears if you select **Options/Circuit restrictions**, if you have previously set a password by clicking **Password** from the **Circuit restrictions** dialog box. For details on the **Circuit restrictions** dialog box, see “1.3.2 Setting Circuit Restrictions” on page 1-9.

2. Enter the default password “Rodney” (this is case sensitive) and click **OK**. The **Global Restrictions** dialog box appears.

**Note** You can, and should, change the default password. (See “1.3.3 Setting Passwords for Restrictions” on page 1-12 for more information).

3. If it is not displayed, click the **General** tab:

Enable these checkboxes to disallow component editing, to hide parts bins, databases, and the In Use List.

See “1.3.1.2 Simplified Version” on page 1-6.

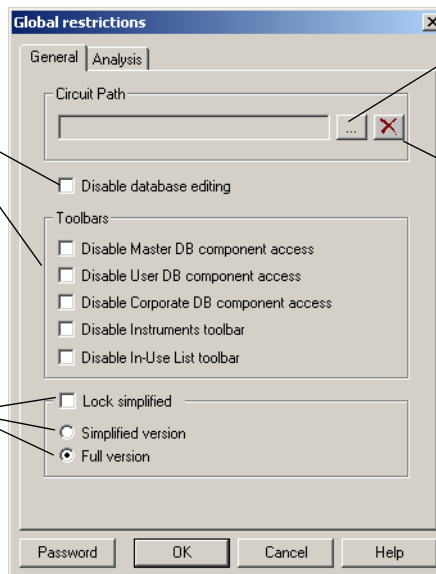

Click here to select a default path/location to store circuits.

Optionally, click to erase circuit path.

4. Select from the following options:

|                                       |  |
|---------------------------------------|--|
| Circuit Path                          | Sets the default path and location where students find and save files.                 |
| Disable database editing              | Ensures that students cannot edit components in the database.                          |
| Disable Master DB component access    | Hides the Multisim Master database and parts groups and families from the interface.   |
| Disable User DB component access      | Hides the “user” database and parts groups and families from the interface.            |
| Disable Corporate DB component access | Hides the corporate library database and parts groups and families from the interface. |
| Disable Instruments toolbar           | Makes instruments unavailable to be placed in the circuit.                             |
| Disable In-Use List toolbar           | Hides the In Use List.   |

5. Click **OK**.

Your options are immediately set for all circuits, unless you have set circuit restrictions. (See “1.3.2 Setting Circuit Restrictions” on page 1-9.)

### 1.3.1.2 Simplified Version

The simplified version restricts students to only certain instruments and analysis. The simplified version can also be locked, preventing students from turning it off with **Options/Simplified Version** and having access to all analyses and instruments.

➤ To set up the simplified version:

1. Display the **General** tab of the **Global Restrictions** dialog box:

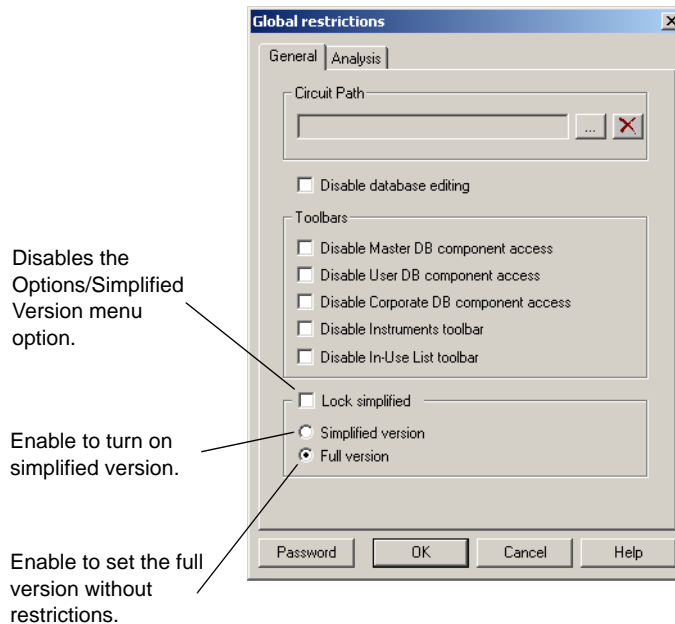

2. Set your options by enabling one of the following options:

|                    |  |
|--------------------|--|
| Simplified version | Changes the interface display by hiding the more complex functions and restricting the available instruments and analyses. If the simplified version is restricted, it will be greyed out in the Options menu. |
| Full version       | Displays the full default interface without restrictions.  |

3. Click **OK**.

Your options are immediately set for all circuits, unless you have set circuit restrictions. (See “1.3.2 Setting Circuit Restrictions” on page 1-9.)

### 1.3.1.3 Global Analyses Restrictions

➤ To set global analyses restrictions:

1. From the **Global Restrictions** dialog box, click the **Analysis** tab.

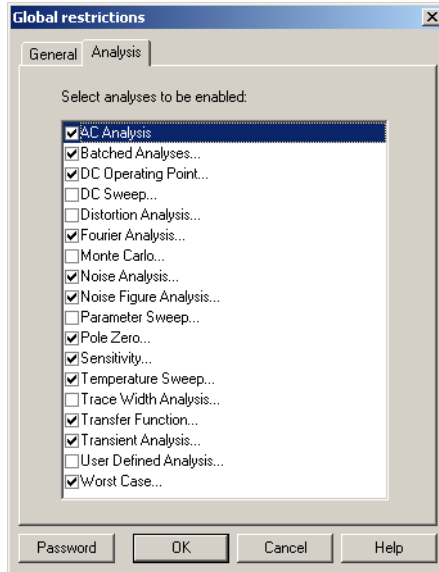

2. Enable the desired analyses by selecting the appropriate checkboxes and click **OK**. Only the analyses you check will be enabled in the **Simulate/Analyses** menu or when the student clicks the **Grapher/Analyses List** button in the **Main** toolbar.

**Note** See Chapter 11, “Analyses”, in the *Multisim 8 User Guide* for more information on analyses.

These options are immediately set for all circuits, unless you have set circuit restrictions. (See “1.3.2 Setting Circuit Restrictions” on page 1-9.)

## 1.3.2 Setting Circuit Restrictions

Use circuit restrictions to set restrictions on individual circuits. Circuit restrictions override global restrictions. They are saved with your circuit and invoked each time the circuit is loaded. In addition to hiding databases and setting available analyses, you can set a schematic to be read-only (not editable by students), you can hide components' values, faults and uses in analyses, and you can lock subcircuits to make them unavailable for opening by students.

**Note** Remember that circuit restrictions only apply to the current circuit; when you create a new circuit, only the global restrictions will apply (see “1.3.1 Setting Global Restrictions” on page 1-4 for details). If you want circuit restrictions to apply to a new circuit, you will need to reset those restrictions each time you create a new circuit.

➤ To set general circuit restrictions:

1. Choose **Options/Circuit Restrictions**. If you have created a password, you will be prompted for it. (See “1.3.3 Setting Passwords for Restrictions” on page 1-12 for more information.) Enter your password in the **Password** dialog box, and click **OK**. The **Circuit Restrictions** dialog box appears.
2. If it is not displayed, click the **General** tab:

The creator of the circuit. (This information is taken from the operating system.)

Enable to set the schematic as “read-only”.

Enable to set the circuit description box as “read-only”.

Enable checkboxes to hide component properties and lock subcircuits.

Enable the appropriate checkboxes to disable desired toolbars, databases, and the In-Use List.

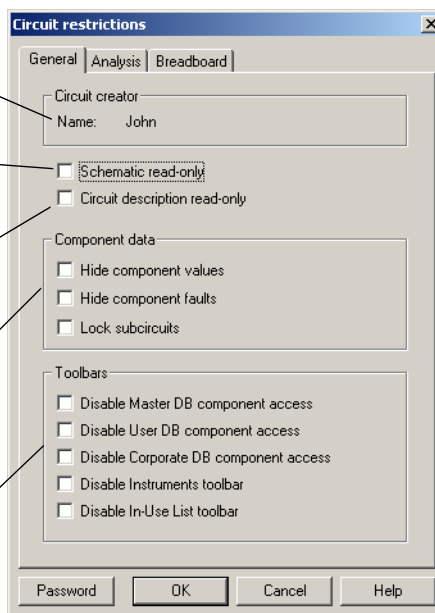

3. Set the desired options by enabling the appropriate checkboxes. Select from the following options:

|   |  |
|---|--|
| Schematic read-only                         | Prevents students from saving the circuit, and hides Parts Bins. Students will only be able to draw wires between instruments and an open pin on an existing connector. Also, they can only remove wires that are between an instrument and a connector. |
| Circuit description read-only               | Prevents students from changing the contents of the Circuit Description box.   |
| Hide component values                       | Marks the Values tab of components' "properties" dialog boxes with an "X" and hides values. You may wish to provide false values using labels.   |
| Hide component faults                       | Marks the Faults tab of components' "properties" dialog boxes with an "X", and hides faults.   |
| Lock subcircuits                            | Prevents students from opening subcircuits and seeing their contents. Students must measure the input and output of a hidden subcircuit to determine its contents.   |
| Disable Multisim Master DB component access | Hides the Multisim Master database and parts groups and families from the current circuit.   |
| Disable User DB component access            | Hides the "user" database and parts groups and families from the current circuit.  |
| Disable Corporate DB component access       | Hides the corporate library database and parts groups and families from the interface.   |
| Disable Instruments toolbar                 | Makes instruments unavailable to be placed on the circuit.   |
| Disable In-Use List toolbar                 | Disables the In-Use List for the current circuit.  |

4. Click **OK**. The options you select are immediately invoked in the circuit.
5. To have the restrictions apply each time the circuit is opened, choose **File/Save** to save the restrictions in the circuit file.

➤ To set circuit analyses restrictions:

1. From the **Circuit Restrictions** dialog box, click the **Analysis** tab:

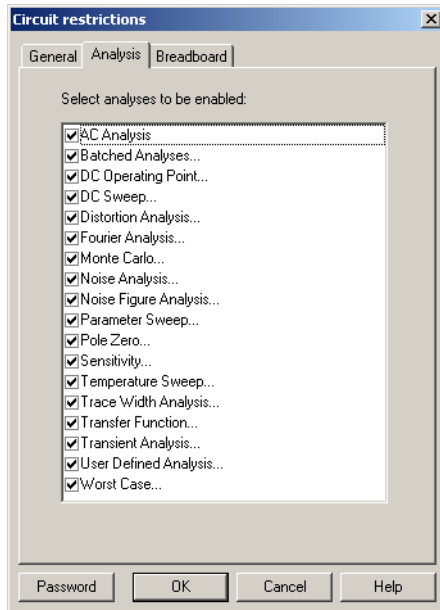

2. Enable the desired analyses by selecting the appropriate checkboxes and click **OK**. Only the analyses you check will be enabled in the **Simulate/Analyses** menu or when the student clicks the **Grapher/Analyses List** button in the **Main** toolbar.

**Note** See Chapter 11, “Analyses”, in the *Multisim 8 User Guide* for more information on analyses.

3. To have these analyses apply each time the circuit is opened, choose **File/Save** to save the restrictions.

➤ To set circuit breadboard restrictions:

1. From the **Circuit Restrictions** dialog box, click the **Breadboard** tab.

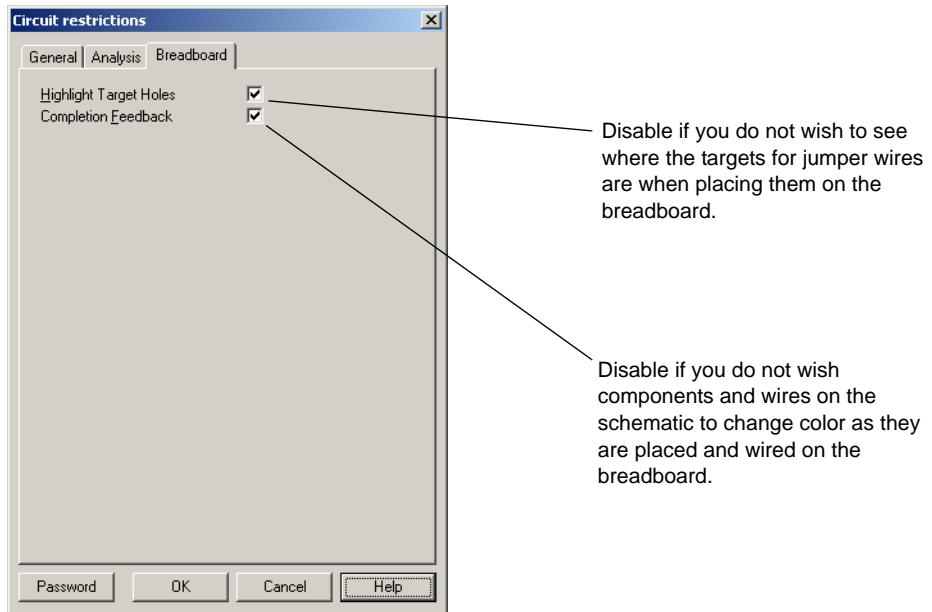

2. Enable the desired analyses by selecting the appropriate checkboxes and click **OK**.

**Note** For details on breadboarding, refer to Chapter 2, “Breadboarding”.

### 1.3.3 Setting Passwords for Restrictions

When using restrictions, you should create a password immediately to ensure that your settings are secure.

➤ To create/change a password:

1. For global restrictions, choose **Options/Global restrictions**. For circuit restrictions, choose **Options/Circuit restrictions**. Enter a password if prompted to do so.

**Note** The default password for global restrictions is “Rodney” (this is case sensitive). Circuit restrictions *do not* have a default password.

- From the restrictions dialog box that appears, click **Password**. The **Change Password** dialog box appears:

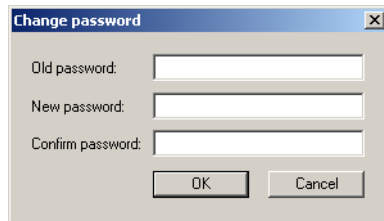

- If you are choosing a password for the first time, leave the **Old password** field blank. If you are changing a password, enter the old password in the **Old password** field.
- Enter your (new) password in the **New password** field.
- Confirm your password by entering it again in the **Confirm password** field.
- Click **OK** to return to the dialog box, or **Cancel** to begin again.

**Note** If you want to change global or circuit restrictions, you will need to enter the respective password. Be sure to keep your passwords for both the **Global restrictions** and **Circuit restrictions** dialogs written down and in a safe place, as you will not be able to retrieve them from the program or circuit files, where they are stored in encrypted form.

**Note** A circuit password is not automatically transferred to a new circuit when you go to set circuit restrictions for it, so you will need to recreate the password every time you create circuit restrictions that you want to keep secure.

## 1.4 Link to Education Resources

**Note** This function is hidden when the simplified version option is selected. For details, see “1.3.1.2 Simplified Version” on page 1-6.

- To go to the Electronics Workbench Education website:



- Click on the **Educational Website** button or select **Tools/Education Webpage**.



# Chapter 2

## Breadboarding

This chapter describes Multisim 8's breadboarding feature.

Some of the features described in this chapter may not be available in your edition of Multisim 8. Refer to the release notes for a description of the features available in your edition.

The following are described in this chapter.

| <b>Subject</b>                              | <b>Page No.</b> |
|---|-----------------|
| <b>Breadboarding Overview</b>               | 2-2             |
| <b>Setting up the Breadboard</b>            | 2-2             |
| Breadboard Settings                         | 2-2             |
| 3D Options                                  | 2-3             |
| <b>Placing Components on the Breadboard</b> | 2-4             |
| <b>Wiring Placed Components</b>             | 2-8             |
| Placing a Jumper                            | 2-8             |
| Changing Jumper Wire Color                  | 2-9             |
| <b>Viewing Component Information</b>        | 2-10            |
| <b>Manipulating the Breadboard View</b>     | 2-12            |
| <b>Breadboard Netlist dialog box</b>        | 2-13            |
| <b>DRC and Connectivity Check</b>           | 2-14            |

## 2.1 Breadboarding Overview

The **Breadboarding** feature provides a technical aid for educators who wish to illustrate breadboarding as a means of prototyping circuit designs. It also gives students exposure to the breadboarding process, and shows in 3D what the resulting breadboard will look like when completed.

## 2.2 Setting up the Breadboard

### 2.2.1 Breadboard Settings

The default breadboard is shown in the screen capture below. If you wish to change the default settings, use the following procedure.

- To change the breadboard's settings:



1. Select **Tools/Show Breadboard** from the main Multisim menu. The **Breadboard View** displays. The default breadboard appears as shown below.

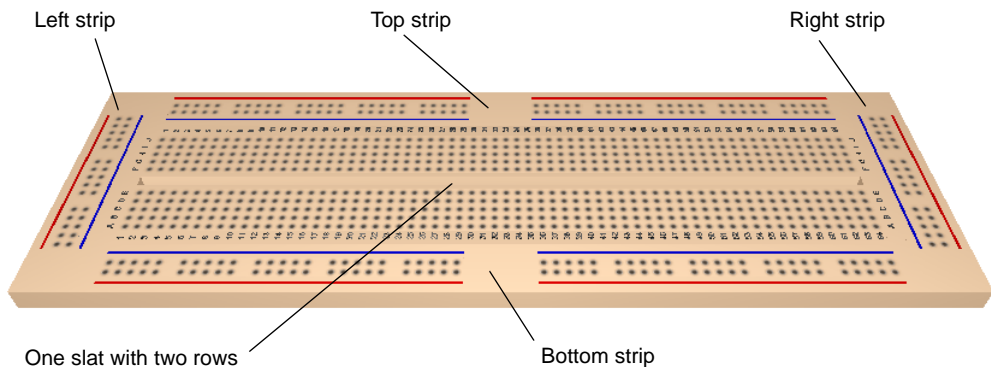

The default breadboard contains: one slat with two rows; one left strip; one right strip; one bottom strip; one top strip.



2. Select **Options/Breadboard Settings** to display the following dialog box.

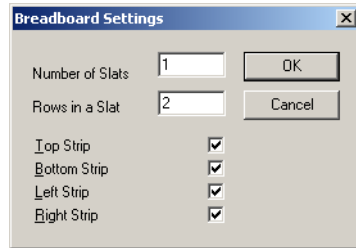

3. Enter the desired parameters for the breadboard and click **OK**. The view of the breadboard changes to reflect your changes.

## 2.2.2 3D Options

The 3D viewing options for the **Breadboard View** are set in the **3D Options** tab of the **Preferences** dialog box.

- To change the 3D options:

1. Select **Options/Preferences** and click on the **3D Options** tab.

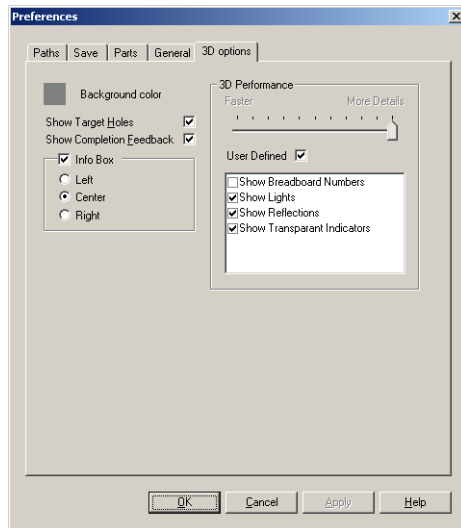

2. Optionally, click on **Background Color** to display a standard **Color** dialog box where you can adjust the background color as desired.

3. In the **Info Box** area:
  - **Info Box** — disable this checkbox if you do not wish to see the box at the top of the breadboard view that shows parts information.
  - **Left** — places parts information box at top-left.
  - **Center** — places parts information box at top-center.
  - **Right** — places parts information box at top-right.
4. Disable the **Show Target Holes** checkbox if you do not wish to see where the targets for jumper wires are when placing them. (For details, see “2.4.1 Placing a Jumper” on page 2-8).
5. Disable the **Show Completion Feedback** checkbox if you do not wish components and wires on the schematic to change color as they are placed and wired on the breadboard.
6. In the **3D Performance** box:
  - Move the slider as desired to improve graphic performance. **More Details** will result in a slower screen refresh rate.
  - Enable the **User Defined** checkbox and disable the 3D features that you do not wish to see.

**Tip** Disabling **Show Breadboard Numbers** will result in a much quicker refresh rate.

## 2.3 Placing Components on the Breadboard

- To place components on a breadboard:
  1. Create a schematic diagram of the desired circuit in the usual manner. (For details, on schematic capture, refer to the *Multisim 8 User Guide*).



2. Select **Tools/Show Breadboard** from the main Multisim menu. The **Breadboard View** displays similar to the following example.

Hover the cursor over a component to see its description in this box.

Refdes : U2  
Value : 74HC190N\_4V  
Footprint : DIP16

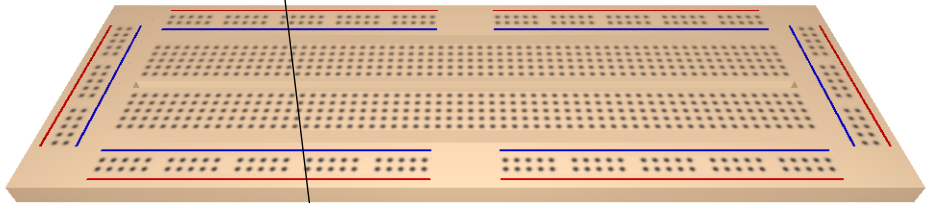

Place Component Bar - components waiting to be placed on the breadboard appear in this area

View other components by clicking on these arrows.

3. Click on a component in the **Place Component Bar** and drag it to the desired location on the breadboard. As the component passes over the breadboard, sockets change color as shown below.

Red sockets indicate where the component's pins will be placed when the mouse button is released.

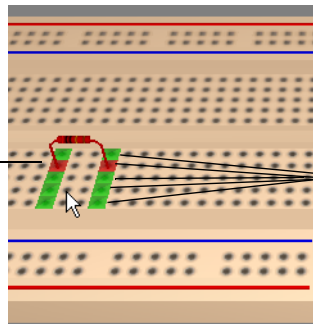

All of these sockets are connected. Green indicates sockets that are internally connected to the red socket in the same row on the breadboard.

**Tip** Select CTRL-R to rotate a selected component 90 degrees clockwise or CTRL-SHIFT-R to rotate it 90 degrees counter-clockwise.

4. Release the mouse button to place the component. Notice that the colored (red and green) sockets on the breadboard no longer appear.

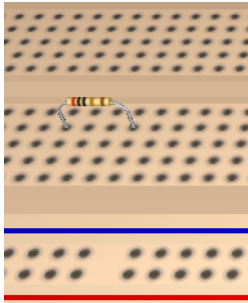

5. Return to the schematic view and note that the color of the placed component has changed as shown in the example below.

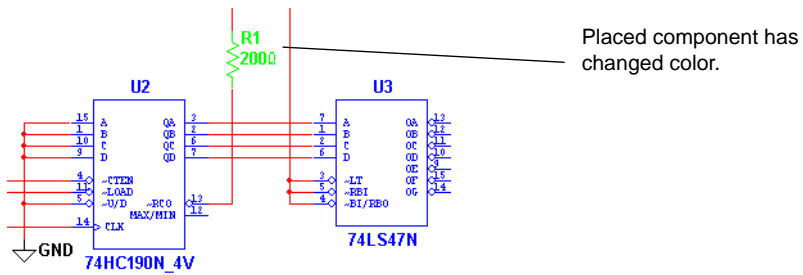

6. Continue placing the circuit's components on the breadboard. When all the components have been placed, the **Place Component Bar** collapses as shown below.

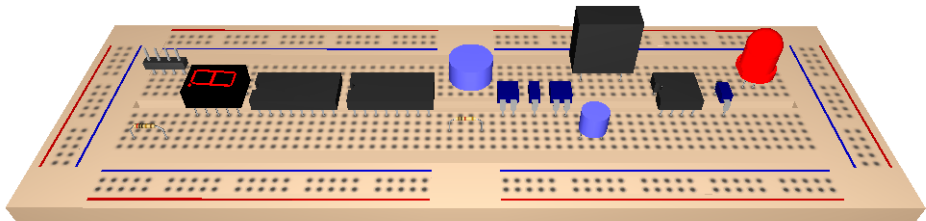

Place Component Bar collapses when all components are placed on the breadboard.



**Tip** Where pins of components are connected on the schematic, you can place them in connected sockets on the breadboard as shown below. This technique can reduce the number of jumper wires required. For details on jumpers, see “2.4.1 Placing a Jumper” on page 2-8.

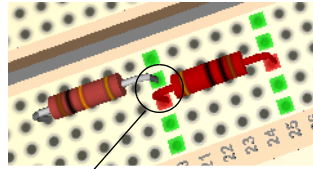

Connected pins

## Appearance of 3D Components

The appearance of the 3D component is dependant on the footprint that is selected from the **Select a Component** browser during schematic capture.

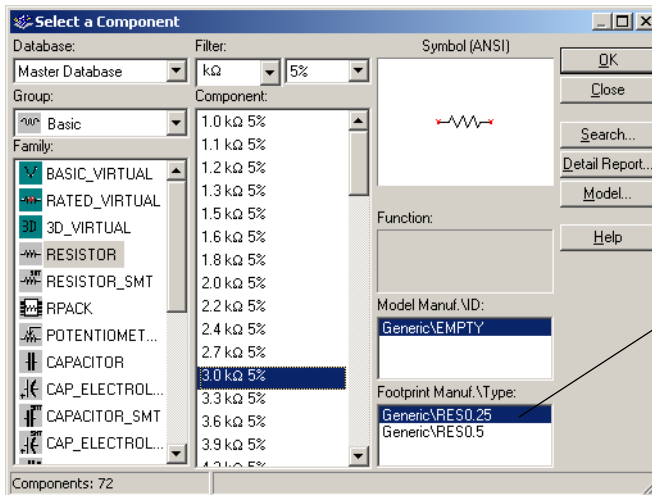

Selected footprint determines 3D appearance in breadboard view.

Some virtual parts have a default 3D view that appears as a blue 3D rectangle or cube. “Real” parts that have pin pitch (spacing) that does not fit the pin pitch on the breadboard will also appear as 3D rectangles or cubes, with properly spaced pins. (See below).

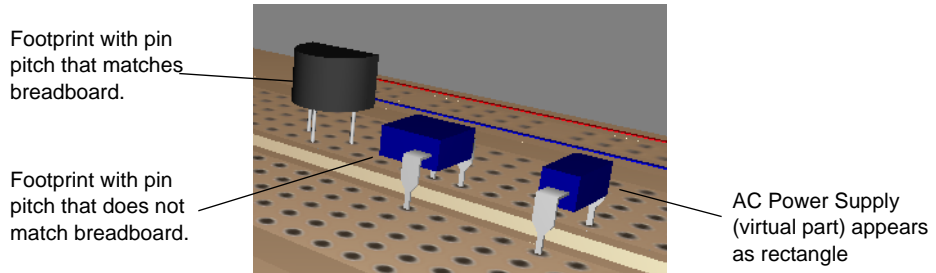

**Note** Certain virtual components, including 3D parts also appear as 3D rectangles or cubes.

**Note** To view footprint information, hover the cursor over the desired component. For details, see “2.5 Viewing Component Information” on page 2-10.

## 2.4 Wiring Placed Components

By placing component pins that are connected on the schematic into sockets that are internally connected, much of the “wiring” can be done at the same time components are placed. However, in most circuits, it will also be necessary to place jumpers to complete the wiring of the placed components.

### 2.4.1 Placing a Jumper

➤ To place a jumper wire:

1. Click on a socket connected to the pin where you wish to start the jumper and begin moving the cursor. Legitimate “target” pins display as shown below.

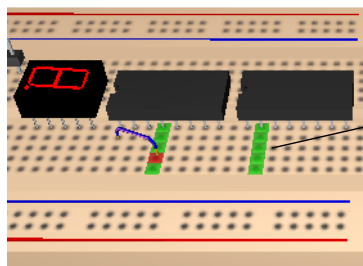

Target pins display once one end of the jumper is placed. You must move the cursor to see the targets.

- Click to place the jumper in the desired socket.

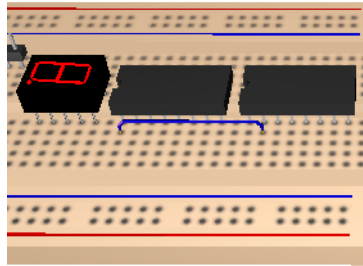

- Return to the schematic view and note that the color of the wire connecting the two pins has changed to green to indicate a connection has been made.

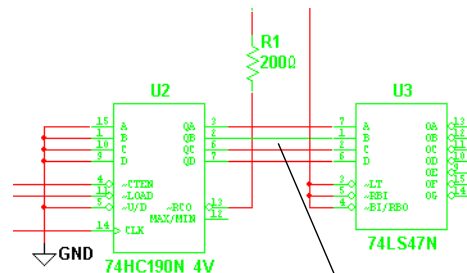

Green wire shows connection on breadboard

**Note** If a net contains more than two connections, all must be connected before any of the wires in the net change color.

- Continue placing jumpers until all schematic connections have been made.

**Tip** Run a Design Rules and Connectivity Check to see if there are any errors in your breadboard. Refer to “2.8 DRC and Connectivity Check” on page 2-14.

## 2.4.2 Changing Jumper Wire Color

- To change jumper wire color:



- Select **Edit/Breadboard Wire Color**.
- Select the desired color from the dialog box that appears.

**Note** The color of previously placed wires is not affected. The new color will be applied to any subsequently placed wires.

## 2.5 Viewing Component Information

- To view information about a specific component:

1. Hover the cursor over the component. The information box is populated as shown below.

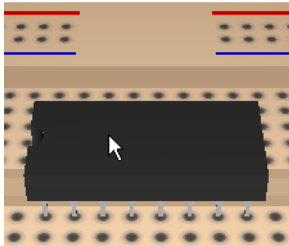
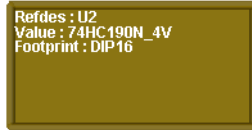

- To see pin information:

1. Hover the cursor over the “metal” part of the desired pin. The information box now includes the pin name and the schematic net to which the pin should be connected.

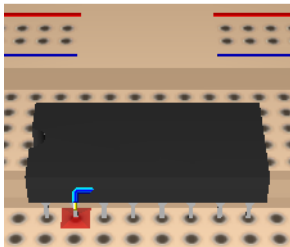
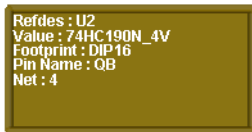

## Two-terminal Components

Two-terminal non-directional components like resistors have pin names (1 and 2) that will automatically swap if they are connected the “wrong way” according to the pin name that is on the schematic.

➤ To view the pin names for all devices on the schematic:

1. Select Options/Sheet Properties and click the **Circuit** tab of the **Sheet Properties** dialog box.

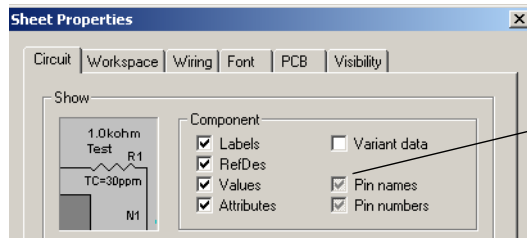

Click until the checkmark is a solid black color.

2. Enable the **Pin names** checkbox as shown above and click **OK** to close the dialog.

Pin 1 of R1 on schematic.

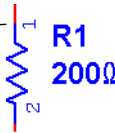

Pin 1 of R1 on breadboard.

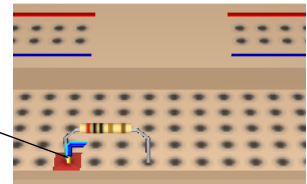

In the above example, if Pin 1 is connected to a pin that should be receiving Pin 2, the pin names will automatically swap. (Pin 1 will become Pin 2 and vice versa).

## 2.6 Manipulating the Breadboard View

You can manipulate the view of the breadboard in a number of ways.

- To make the breadboard appear larger:



1. Select **View/Zoom in**.

- To make the breadboard appear smaller:



1. Select **View/Zoom out**.

**Tip** Use your mouse's center wheel to zoom in or out. (This must be set up in the **General** tab of the **Preferences** dialog box. For details, refer to the *Multisim 8 User Guide*).

- To view the entire breadboard:



1. Select **View/Zoom Full**.

- To rotate the breadboard 180 degrees:



1. Select **View/Rotate 180 Degrees**

*Or*

Press SHIFT-R on your keyboard.

**Tip** Rotate the breadboard in any direction by dragging the mouse from a blank area of the **Breadboard View**. You can also rotate the breadboard by using the arrow keys on your keyboard.

- To pan the breadboard:

1. Hold down the SHIFT key on your keyboard and use any of the arrow keys.

*Or*

Press CTRL-SHIFT and drag the mouse.

## 2.7 Breadboard Netlist dialog box

- To display a netlist for the placed components and jumpers:



1. Select **Tools/Show Breadboard Netlist**. The **Breadboard Netlist** dialog box appears.

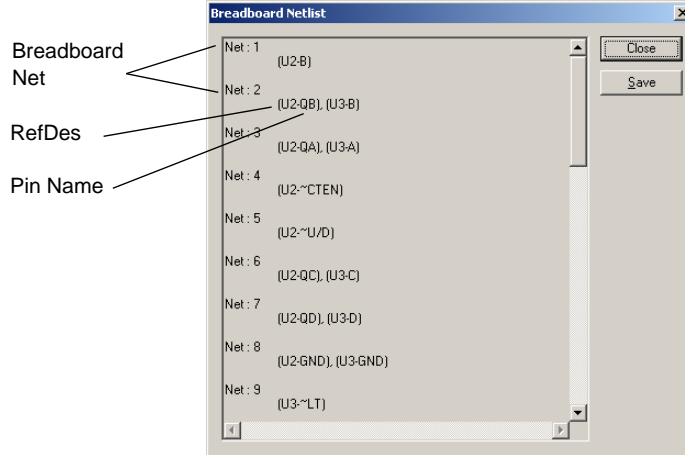

2. Optionally, click **Save** to save the breadboard netlist as a .txt or .csv file.

**Note** These nets are breadboard connections, and are not necessarily numbered in correspondence to the schematic nets.

## 2.8 DRC and Connectivity Check

You can run a Design Rules and Connectivity Check to see if there are any errors in your breadboard.

- To run a DRC and Connectivity Check:
  1. Select **Tools/DRC and Connectivity Check**. The results appear in the **Results** tab of the **Spreadsheet View**.

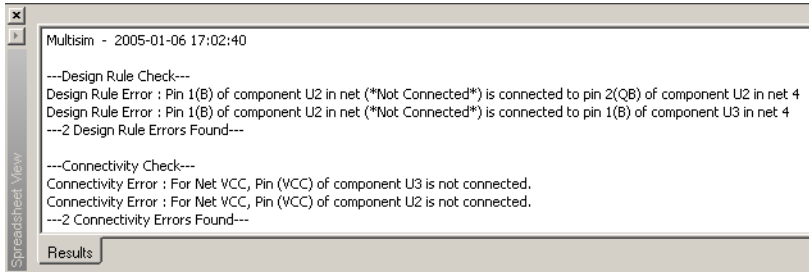

**Design Rule Errors** — indicate connections that are on the breadboard that are not on the schematic.

**Connectivity Check Errors** — indicate component pins that are not connected to fully-completed schematic nets.

# Chapter 3

## Ladder Diagrams

This chapter describes the ladder diagram functionality that Multisim contains.

Some of the features described in this chapter may not be available in your edition of Multisim 8. Refer to the release notes for a description of the features available in your edition.

The following are described in this chapter.

| Subject                   | Page No. |
|---------------------------|----------|
| Overview                  | 3-1      |
| Creating a Ladder Diagram | 3-2      |
| AND Rungs and OR Rungs    | 3-5      |
| Sample Circuits           | 3-7      |
| Holding Tank              | 3-7      |
| Conveyor Belt             | 3-12     |
| Traffic Light             | 3-17     |

### 3.1 Overview

The Education edition of Multisim lets you capture and simulate **Ladder Diagrams**. These diagrams are electrically based, as opposed to the binary/digital representations employed by ladder *logic*. Diagrams of this type are used extensively for industrial motor control circuits.

**Ladder Diagrams** are able to drive output devices or take input data from regular schematics and embed the instructions on how input states affect output states in either the same schematic or separate hierarchical blocks or subcircuits that contain the **Ladder Diagram**.

**Note** Refer to the *Multisim 8 User Guide* for a complete description of hierarchical blocks and subcircuits.

## 3.2 Creating a Ladder Diagram

This section describes the steps required to make a simple **Ladder Diagram**. The concepts described here should be understood before reviewing the more complex circuits found in this chapter.

This section describes how to build the **Ladder Diagram** that is reviewed in “3.3 AND Rungs and OR Rungs” on page 3-5.

**Note** For details on all ladder diagram components, refer to “A.3 Ladder Diagram Parts” on page A-23.

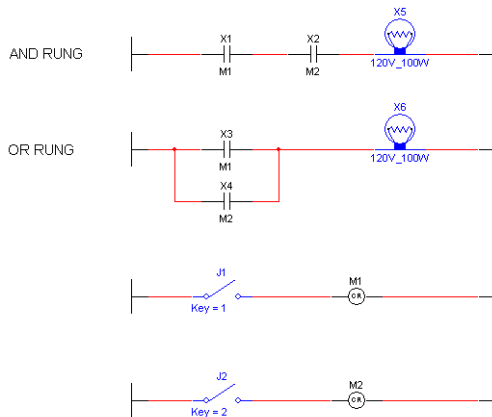

### Circuit Notes:

- The relays (X1-X4) are normally open relays. When their controlling coils (M1 or M2) are energized they close. (The controlling coils are set in the **Value** tab of each relay’s properties dialog box. For details, see “A.3.4.4 Relay Contact NO” on page A-28).
- Both X1 AND X2 must be closed for the lamp in the AND rung (X5) to light up.
- Either X3 OR X4 must be closed for the lamp in the OR rung (X6) to light up.
- Coil M1 controls the relays with M1 as their reference. (X1 and X3).
- Coil M2 controls the relays with M2 as their reference. (X2 and X4).
- Use keys 1 and 2 on your keyboard to open and close switches J1 and J2.

➤ To add the diagram’s rungs:



1. Select **Place/Ladder Rungs**. The cursor appears with the rung’s left and right terminators attached.



- Click to place the first rung and continue clicking and placing until you have placed four rungs as shown below. Right-click to stop placing rungs.

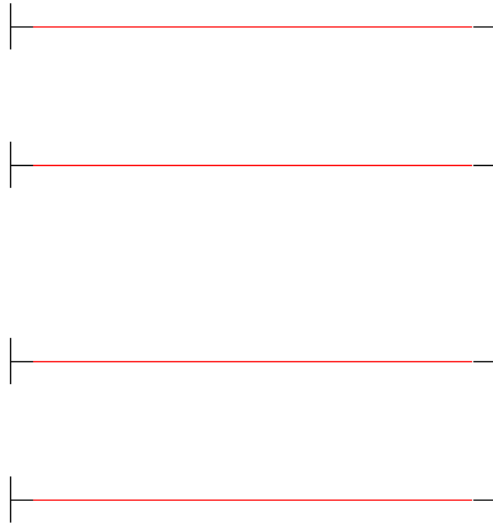

- To add components to the rungs:

- Select **Place/Component**, navigate to the Normally Open Relay Contact as shown below and click **OK**.

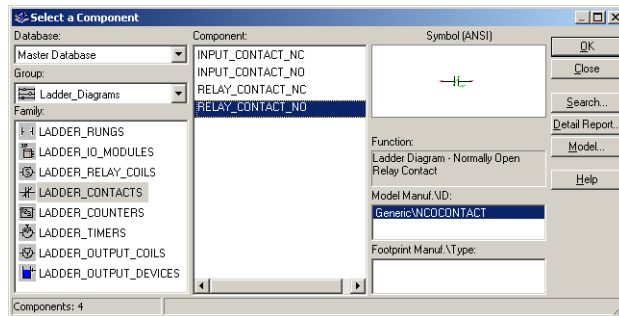

- Drop the relay contact directly onto the first rung.



3. Continue in this manner until all relay contacts have been placed. (X4 must be placed and then wired separately).

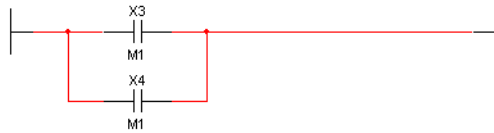
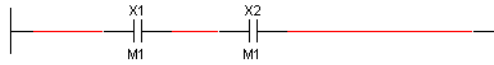

4. Place the lamps (Group - Indicators; Family - Lamp).

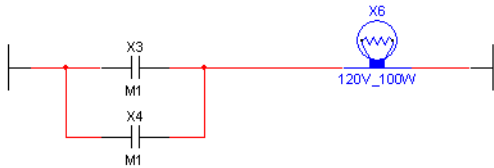

5. Place relay coils M1 and M2 on the third and fourth rungs (Group - Ladder Diagrams; Family - Ladder Relay Coils).



6. Place switches J1 and J2.

7. Double-click on each switch, select the **Value** tab, and change the key for J1 to 1 and the key for J2 to 2.

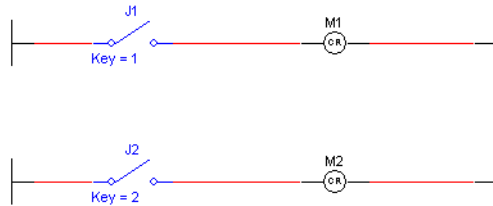

- To change the controlling device reference for X2 and X4:

1. Double-click on X2 and click the **Value** tab.
2. Enter M2 in the **Controlling Device Reference** field and click **OK**.

Repeat for X4. The completed **Ladder Diagram** appears as shown below.

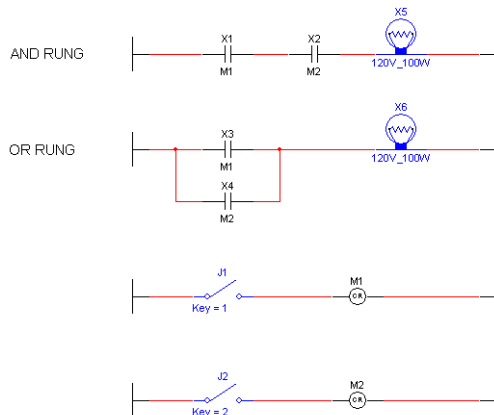

### 3.3 AND Rungs and OR Rungs

This section illustrates the difference between AND rungs and OR rungs that are found in **Ladder Diagrams**. The concepts described here should be understood before reviewing the more complex circuits found in this chapter.

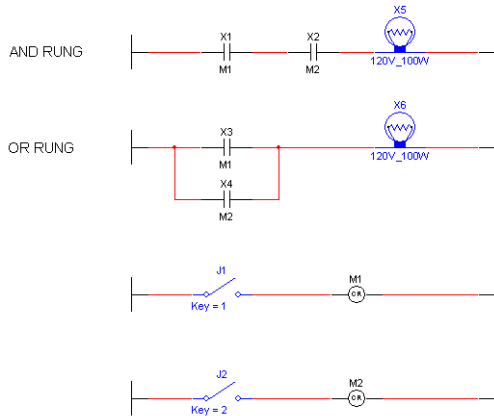

➤ To activate the lamp in the OR rung:

1. Select **Simulate/Run** to start simulation of the circuit.
2. Press 1 on your keyboard to close J1. Lamp X6 lights as described below.

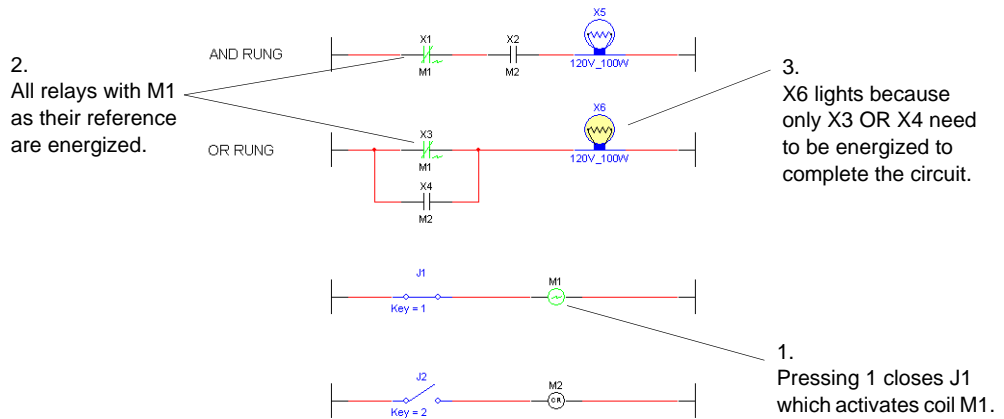

If you press 2 on your keyboard, J2 closes which activates coil M2. X6 lights because X4 is energized.

➤ To active the lamp in the AND rung:

1. Select **Simulate/Run** to start simulation of the circuit.

- Press 1 and 2 on your keyboard to close J1 and J2. Lamps X5 and X6 light as described below.

- All relays with M1 and M2 as their references are energized.

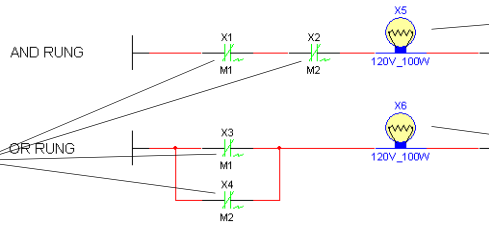

- X5 lights because X1 AND X2 are energized and the circuit is complete.

- X6 lights because X3 OR X4 is energized and the circuit is complete.



- Pressing 1 closes J1 which activates coil M1.



- Pressing 2 closes J2 which activates coil M2.

## 3.4 Sample Circuits

### 3.4.1 Holding Tank

This section contains an example of a logic diagram that drives a circuit that fills and then empties a fluid holding tank.

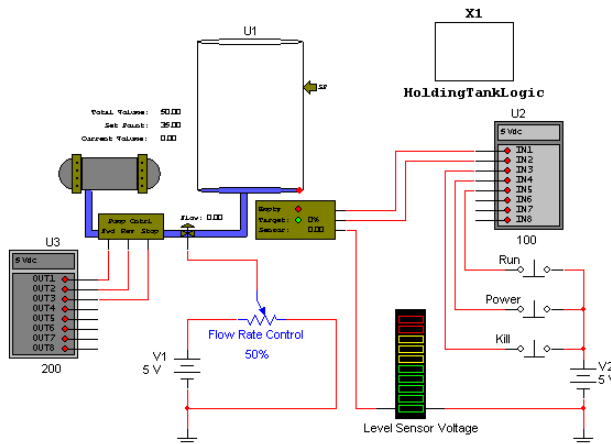

For details on the user-settable parameters for the Holding Tank, Input Module and Output Module, see "A.3 Ladder Diagram Parts" on page A-23

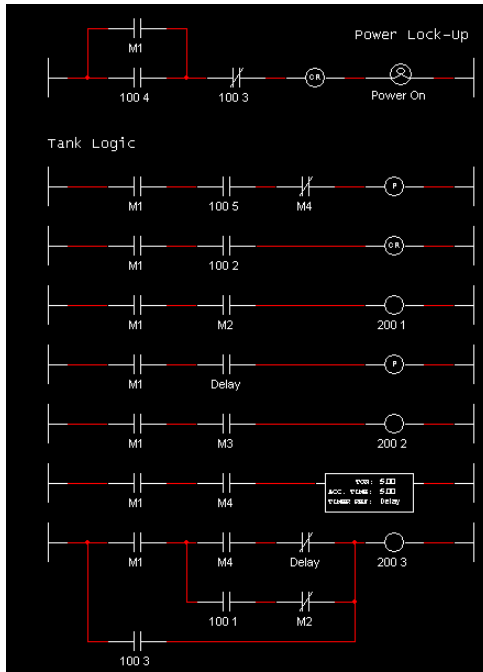

The Ladder Diagram is contained in a separate Hierarchical Block called HoldingTankLogic. For details on hierarchical blocks, refer to the Multisim 8 User Guide.

➤ To activate this circuit:

1. Select **Simulate/Run** to begin simulation.
2. Press P on your keyboard to activate the Power temporary switch. This sends 5 V to pin IN4 of Input Module U2 (**Input Module Base Address = 100**) which in turn energizes Input



3. As the simulation proceeds, the tank begins to fill.

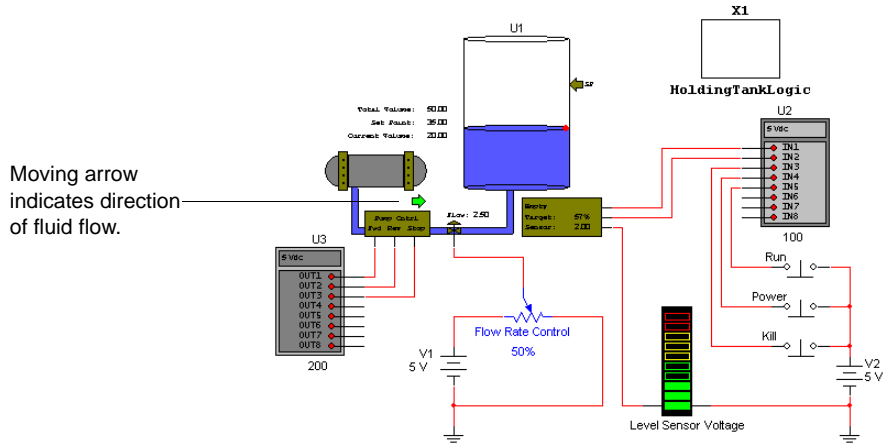

4. When the level of the fluid in the tank gets to the **Set Point**, fluid stops being pumped.

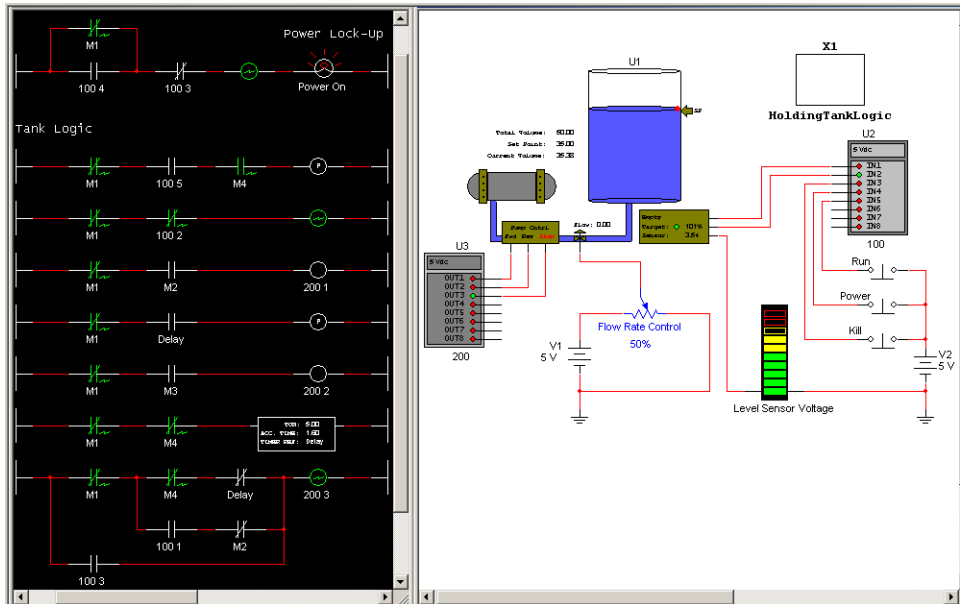

5. After a delay of five seconds, the tank begins to empty.

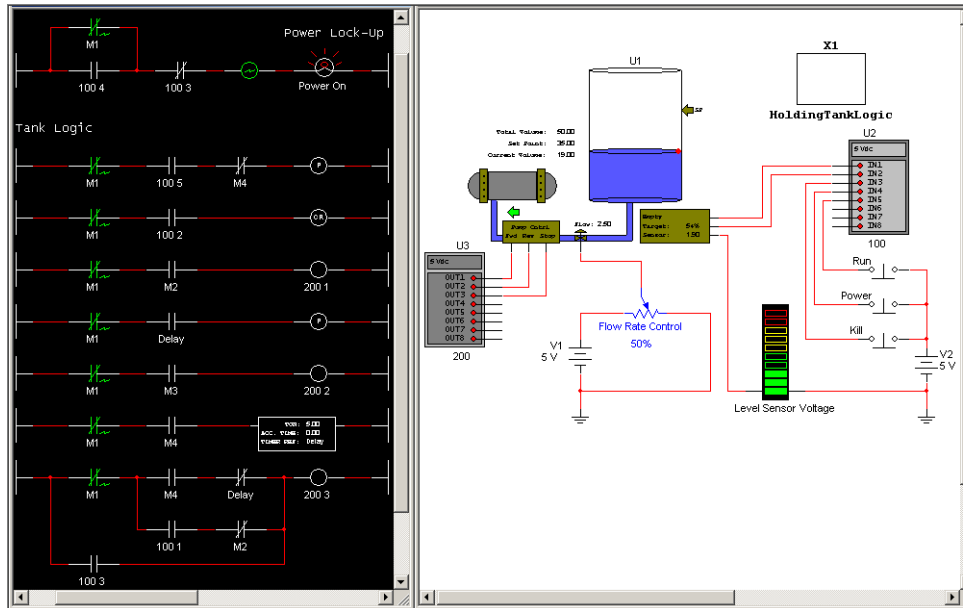

6. When the tank is empty, the flow stops.

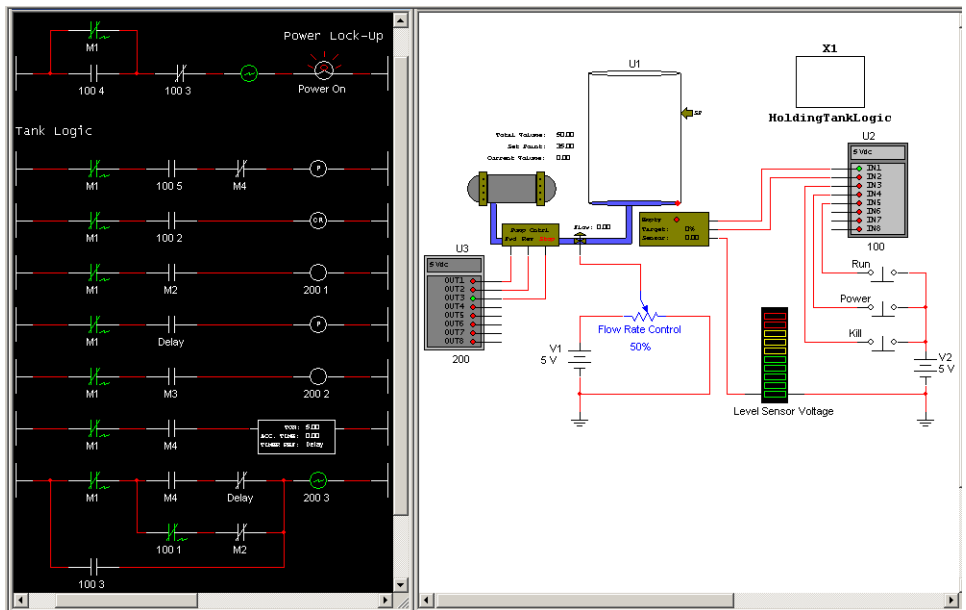

- To turn off the power at any point in the simulation:
  1. Press K on your keyboard to activate the Kill temporary switch. This sends 5 V to pin IN3 of Input Module U2 (**Input Module Base Address** = 100) which in turn energizes Input Contact X2 (the contact opens). The continuity in the Power Lock-up Rung is broken and Relay Coil M1 is de-energized, which in turn switches off all Relay Contacts with **Relay Device Reference** = M1.

When you press K, X20 is also temporarily energized, which in turn temporarily energizes Output Coil Y2, which sends a pulse to pin Out3 of Output Module U3. This is wired to the **Stop** pin of the holding tank, so the tank stops filling or emptying (depending on which is currently occurring).

## 3.4.2 Conveyor Belt

This section contains an example of a **Ladder Diagram** that drives a conveyor belt.

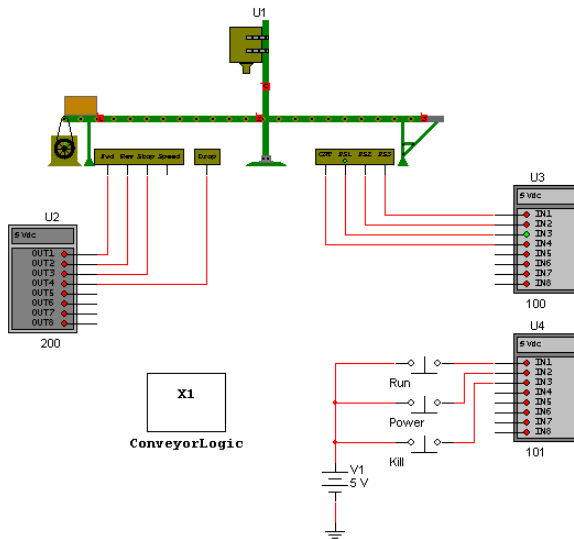

For details on the user-settable parameters for the Conveyor Belt, Input Module and Output Module, see “A.3 Ladder Diagram Parts” on page A-23

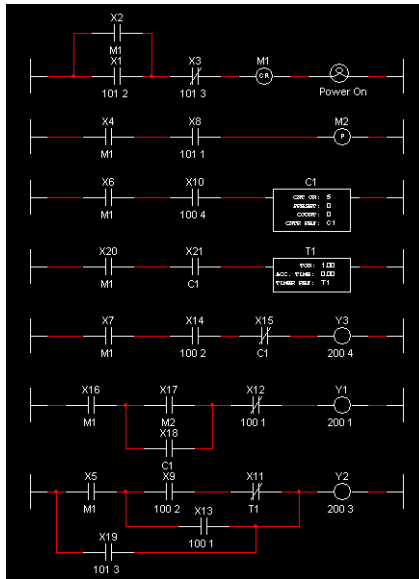

The Ladder Diagram is contained in a separate Hierarchical Block called ConveyorLogic. For details on hierarchical blocks, refer to the Multisim 8 User Guide.

➤ To activate this circuit:

1. Select **Simulate/Run** to begin simulation.
2. Press P on your keyboard to activate the Power temporary switch. This sends 5 V to pin IN2 of Input Module U4 (**Input Module Base Address = 101**) which in turn energizes Input

Contact X1 in the Power Lock-up Rung of the ladder diagram. Relay Coil M1 is energized, causing all Relay Contacts with **Relay Device Reference = M1** to energize.

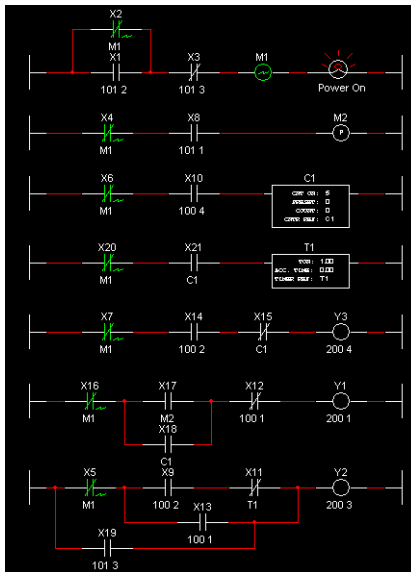

➤ To run the conveyor belt:

1. Activate the circuit as described earlier.
2. Press R on your keyboard to activate the Run temporary switch.

**Tip** Select **Window/Tile Vertical** to view the ladder diagram and the circuit at the same time. Observe the interaction between the ladder diagram and the circuit as the simulation proceeds.

- As the simulation proceeds, the box moves along the conveyor belt to Position Sensor 2 (PS2). The box stops moving and balls begin dropping from the hopper into the box.

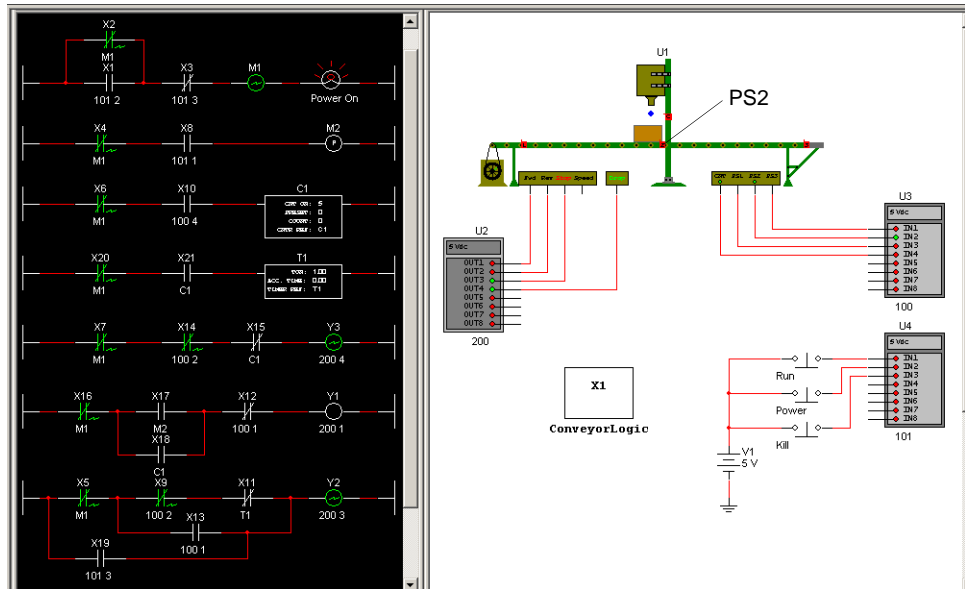

- When five balls have dropped into the box (counted by Count sensor and C1), the hopper stops dropping balls.

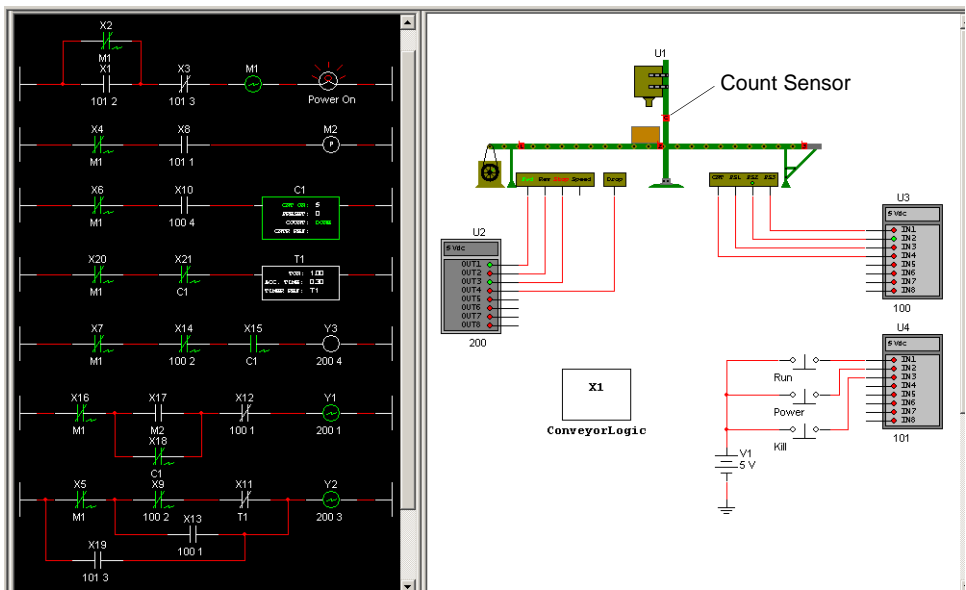

5. The conveyor continues moving and stops when the box gets to Position Sensor 3 (PS3).

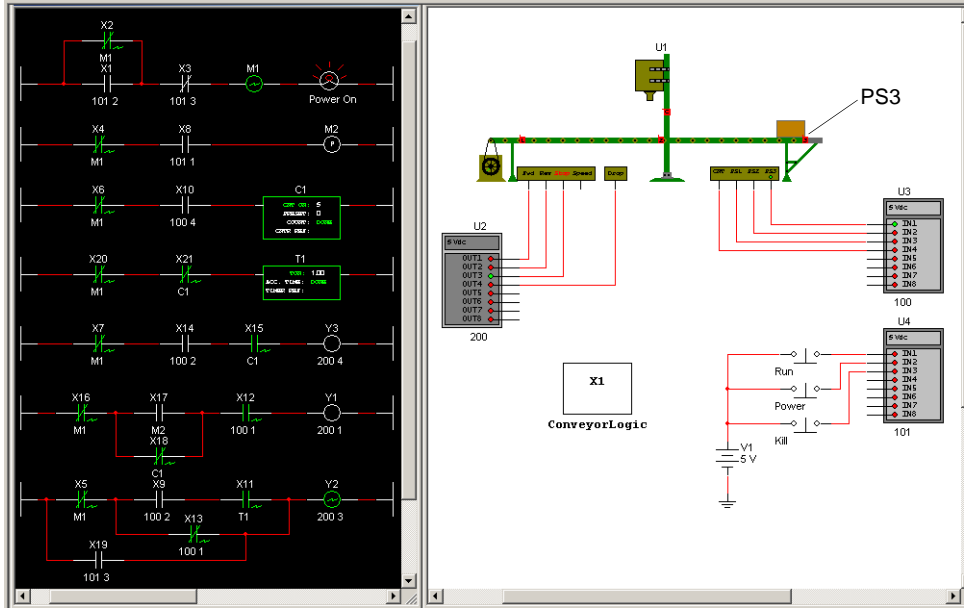

- To turn off the power at any point in the simulation:
  1. Press K on your keyboard to activate the Kill temporary switch. This sends 5 V to pin IN3 of Input Module U4 (**Input Module Base Address = 101**) which in turn energizes Input Contact X3 (the contact opens). The continuity in the Power Lock-up Rung is broken and Relay Coil M1 is de-energized, which in turn switches off all Relay Contacts with **Relay Device Reference = M1**.  
 When you press K, X19 is also temporarily energized, which in turn temporarily energizes Output Coil Y2, which sends a pulse to pin Out3 of Output Module U2. This is wired to the **Stop** pin of the conveyor belt, so the belt stops.

### 3.4.3 Traffic Light

The ladder diagram in this section runs two traffic lights.

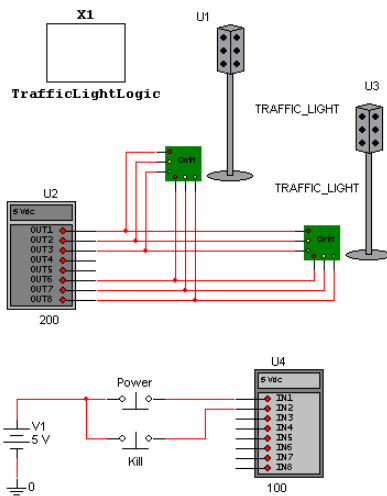

The Ladder Diagram is contained in a separate Hierarchical Block called TrafficLightLogic. For details on hierarchical blocks, refer to the Multisim 8 User Guide.

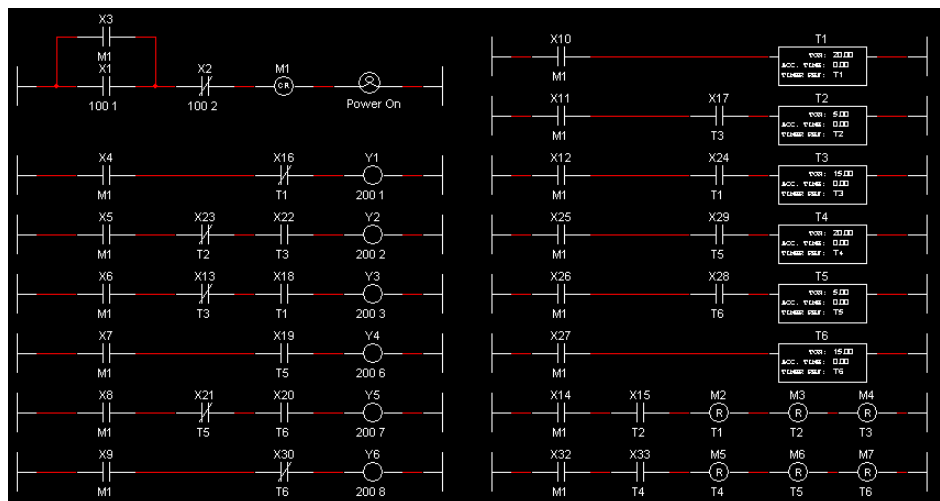

- To run the traffic lights:
  1. Select **Simulate/Run**.
  2. Press P on your keyboard to activate the Power momentary switch.

**Tip** Select **Window/Tile Vertical** to view the ladder diagram and the circuit at the same time. Observe the interaction between the ladder diagram and the circuit as the simulation proceeds.

3. The red and green lights in traffic lights U1 and U3 light as shown below.

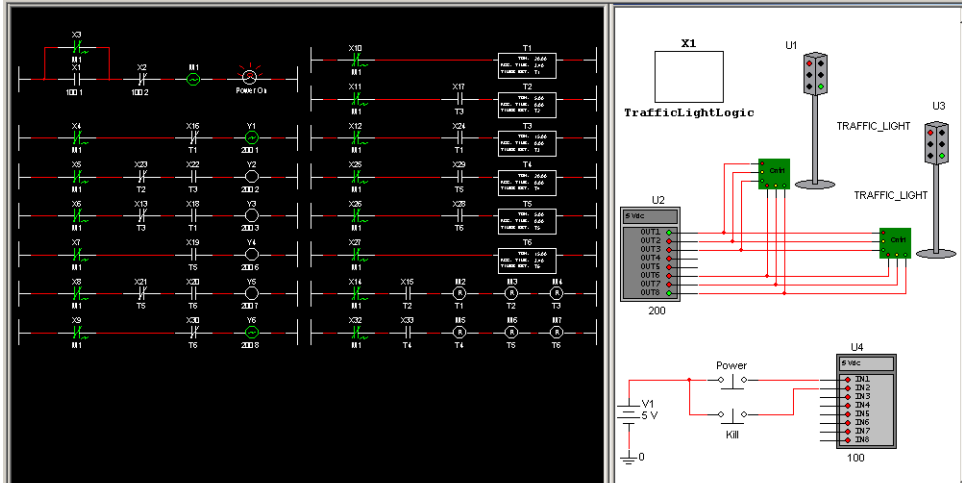

4. After 15 seconds, the green lights turn amber.

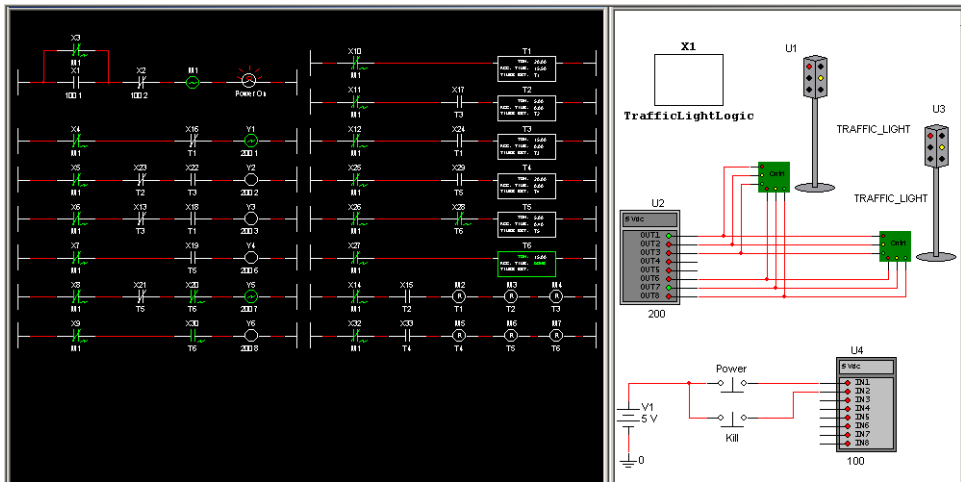

5. After 5 more seconds, the amber lights turn red and the red lights turn green.

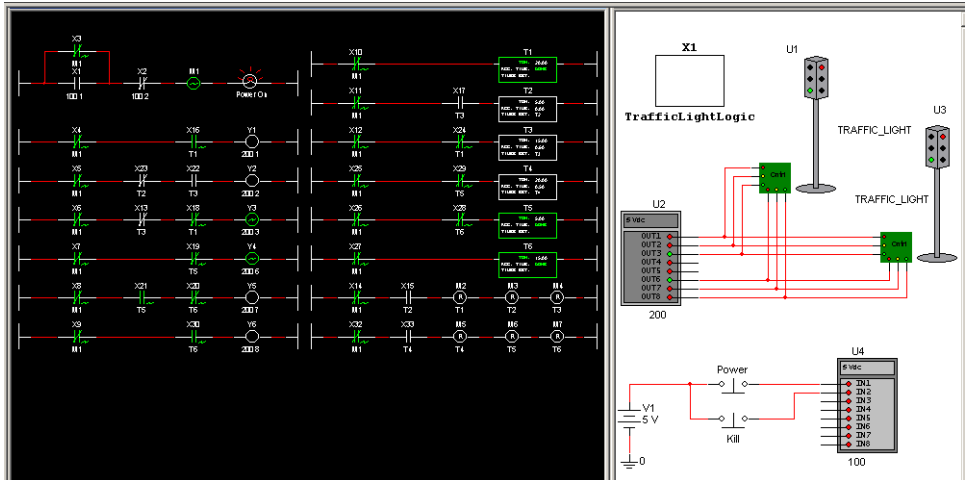

6. After 15 seconds, the green lights turn amber.

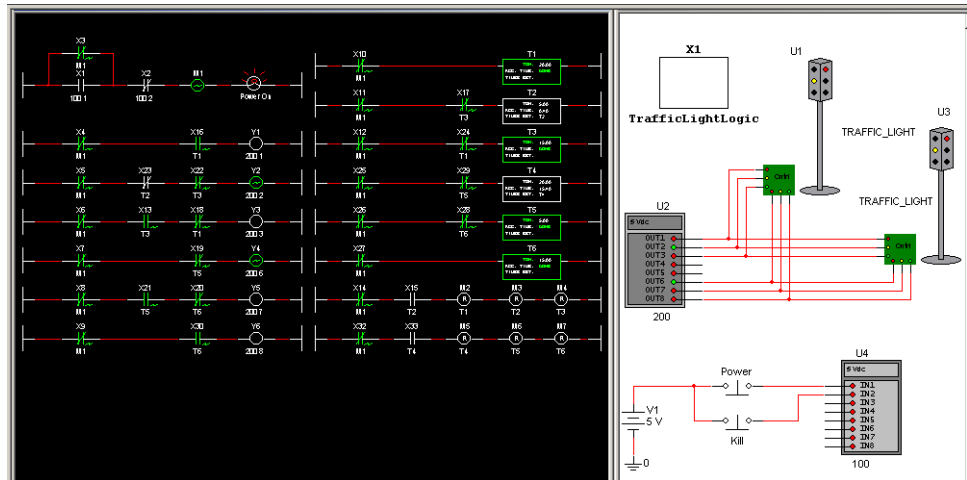

7. After 5 more seconds, the amber lights turn red and the red lights turn green.

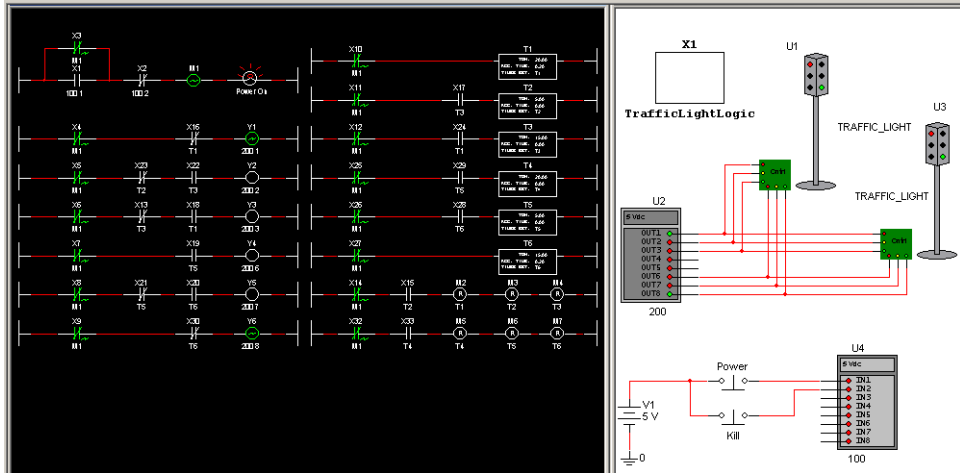

8. The cycle continues in this way until you stop the simulation, or press K to activate the Kill momentary switch.

# Appendix A - Education Edition Parts

This appendix contains a description of the parts that are unique to the Education edition of Multisim 8.

## A.1 Rated Virtual Components

This component family contains a number of virtual components that can be rated to “blow” if pre-set tolerance(s) are exceeded when the circuit is simulated. These tolerances are set in the **Values** tab of each component’s properties window.

**Tip** “Rated” values in a component’s **Value** tab define behavior and design. “Maximum” values impose limits that, when exceeded, cause the component to “blow”.

The rated virtual components are found in the **Basic Group** in the **Rated Virtual** family as shown below.

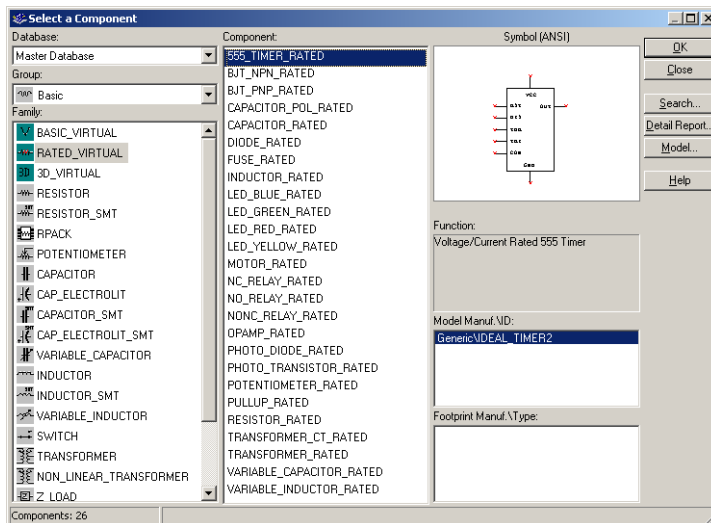

---

## A.1.1 Rated 555 Timer

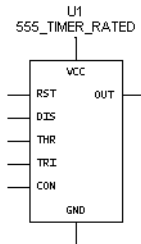

The 555 timer is an IC chip that is commonly used as an astable multivibrator, a monostable multivibrator or a voltage-controlled oscillator. The 555 timer consists basically of two comparators, a resistive voltage divider, a flip-flop and a discharge transistor. It is a two-state device whose output voltage level can be either high or low. The state of the output can be controlled by proper input signals and time-delay elements connected externally to the 555 timer.

**Note** Refer to the *Component Reference Guide* for a more detailed discussion of the 555 timer.

- To adjust the component's tolerances:
1. Double-click on the placed component and click the **Value** tab.
  2. Change the following values as desired:
    - **Animation Delay Factor** — increase this number to slow the speed of animation of the symbol blowing. This is not a real-time value.
    - **Maximum Supply Voltage** — the maximum supply voltage allowed. If this is exceeded during simulation, the timer's VCC pin blows.
    - **Maximum Output Current** — the maximum output current allowed. If this is exceeded during simulation, the timer's OUT pin blows.
  3. Click **OK**.

## A.1.2 Rated BJTs



A bipolar junction transistor, or BJT, is a current-based valve used for controlling electronic current. BJTs are operated in three different modes, depending on which element is common to input and output: common base, common emitter or common collector. The three modes have different input and output impedances and different current gains, offering individual advantages to a designer.

**Note** Refer to the *Component Reference Guide* for a more detailed discussion of BJTs.

- To adjust the component's tolerances:
  1. Double-click on the placed component and click the **Value** tab.
  2. Change the following values as desired:
    - **Animation Delay Factor** — increase this number to slow the speed of animation of the symbol blowing. This is not a real-time value.
    - **Maximum Collector-Emitter Voltage** — the maximum collector-emitter voltage allowed. If this value is exceeded during simulation, the BJT blows.
    - **Maximum Collector-Base Voltage** — the maximum collector-base voltage allowed. If this value is exceeded during simulation, the BJT blows.
    - **Maximum Emitter-Base Voltage** — the maximum emitter-base voltage allowed. If this value is exceeded during simulation, the BJT blows.
    - **Maximum Collector Current** — the maximum collector current allowed. If this value is exceeded during simulation, the BJT blows.
    - **Saturation Current** — the maximum saturation current allowed. If this value is exceeded during simulation, the BJT blows.
    - **Maximum Forward Beta** — the maximum forward beta allowed. If this value is exceeded during simulation, the BJT blows.
  3. Click **OK**.

---

## A.1.3 Rated Capacitors



A capacitor stores electrical energy in the form of an electrostatic field. Capacitors are widely used to filter or remove AC signals from a variety of circuits. In a DC circuit, they can be used to block the flow of direct current while allowing AC signals to pass.

A capacitor's capacity to store energy is called its capacitance,  $C$ , which is measured in farads. It can have any value from pF to mF.

The variable capacitor is simulated as an open circuit with a current across the capacitor forced to zero by a large impedance value.

The polarized capacitor must be connected with the right polarity. Otherwise, an error message will appear. Its capacitance, measured in farads, can be any value from pF to F.

**Note** Refer to the *Component Reference Guide* for a more detailed discussion of capacitors.

➤ To adjust the component's tolerances:

1. Double-click on the placed component and click the **Value** tab.
2. Change the following values as desired:
  - **Animation Delay Factor** — increase this number to slow the speed of animation of the symbol blowing. This is not a real-time value.
  - **Capacitance** — set the capacitance as desired.
  - **Voltage Rating (Pk)** — the maximum peak voltage across the capacitor allowed. If this value is exceeded during simulation, the capacitor blows.
  - **Initial Conditions** — the initial charge across the capacitor, before simulation begins.
3. Click OK.

## A.1.4 Rated Diodes



Diodes allow current to flow in only one direction and can therefore be used as simple solid-state switches in AC circuits, being either open (not conducting) or closed (conducting). Terminal A is called the anode and terminal K is called the cathode.

**Note** Refer to the *Component Reference Guide* for a more detailed discussion of diodes.

- To adjust the component's tolerances:
1. Double-click on the placed component and click the **Value** tab.
  2. Change the following values as desired:
    - **Animation Delay Factor** — increase this number to slow the speed of animation of the symbol blowing. This is not a real-time value.
    - **Reverse Breakdown Voltage** — set as desired.
    - **Current at Breakdown Voltage** — set as desired.
    - **Saturation Current** — the maximum current through the capacitor allowed. If this value is exceeded during simulation, the diode blows.
    - **Transit Time (sec)** — set as desired.
  3. Click **OK**.

## A.1.5 Rated Fuses



This is a resistive component that protects against power surges and current overloads.

A fuse will blow (open) if the current in the circuit goes above  $I_{max}$ , the maximum current rating.  $I_{max}$  can have any value from mA to kA.

**Note** Refer to the *Component Reference Guide* for a more detailed discussion of fuses.

- To adjust the component's tolerances:
1. Double-click on the placed component and click the **Value** tab.
  2. Change the following values as desired:
    - **Animation Delay Factor** — increase this number to slow the speed of animation of the symbol blowing. This is not a real-time value.
    - **Maximum Current (Imax)** — the maximum current allowed through the fuse. If this value is exceeded during simulation, the fuse blows.
  3. Click **OK**.

---

## A.1.6 Rated Inductors



An inductor stores energy in an electromagnetic field created by changes in current through it. Its ability to oppose a change in current flow is called inductance,  $L$ , and is measured in Henrys. An inductor can have any value from  $\mu\text{H}$  to H.

**Note** Refer to the *Component Reference Guide* for a more detailed discussion of inductors.

- To adjust the component's tolerances:
  1. Double-click on the placed component and click the **Value** tab.
  2. Change the following values as desired:
    - **Animation Delay Factor** — increase this number to slow the speed of animation of the symbol blowing. This is not a real-time value.
    - **Inductance** — the coil's inductance. Set as desired.
    - **Coil Resistance** — set as desired.
    - **Current Rating (Pk)** — the maximum peak current allowed through the inductor. If this value is exceeded during simulation, the inductor blows.
    - **Initial Conditions** — the initial current through the inductor, before simulation begins.
  3. Click **OK**.

## A.1.7 Rated LEDs



This diode emits visible light when forward current through it,  $I_a$ , exceeds the turn-on current,  $I_{on}$ . The electrical model of the LED is the same as the diode model.

**Note** Refer to the *Component Reference Guide* for a more detailed discussion of LEDs.

- To adjust the component's tolerances:
  1. Double-click on the placed component and click the **Value** tab.

2. Change the following values as desired:
  - **Animation Delay Factor** — increase this number to slow the speed of animation of the symbol blowing. This is not a real-time value.
  - **On Current (Ion)** — the current required to switch the LED on.
  - **Forward Voltage Drop (Vf)** — the voltage drop across the LED when it is conducting.
  - **Reverse Breakdown Voltage** — set as desired.
  - **Maximum Rated Power (Watts)** — the maximum power dissipation across the LED allowed. If this value is exceeded during simulation, the inductor blows.
3. Click **OK**.

## A.1.8 Rated DC Motor



The component is a universal model of an ideal DC motor which can be used to model the behavior of a DC motor excited in parallel, in series or separately.

**Note** Refer to the *Component Reference Guide* for a more detailed discussion of DC motors.

- To adjust the component's tolerances:
  1. Double-click on the placed component and click the **Value** tab.
  2. Change the following values as desired:
    - **Animation Delay Factor** — increase this number to slow the speed of animation of the symbol blowing. This is not a real-time value.
    - **Rated Armature Voltage (Van)** — set as desired.
    - **Maximum Armature Voltage** — the maximum voltage across the armature allowed. If this value is exceeded during simulation, the motor blows.
    - **Rated Armature Current (Ian)** — set as desired.
    - **Maximum Armature Current** — the maximum current through the armature allowed. If this value is exceeded during simulation, the motor blows.
    - **Rated Field Voltage (Vfn)** — set as desired.
    - **Maximum Field Voltage** — the maximum field voltage allowed. If this value is exceeded during simulation, the motor blows.
    - **Armature Resistance (Ra)** — set as desired.
    - **Armature Inductance (La)** — set as desired.
    - **Field Resistance (Rf)** — set as desired.
    - **Field Inductance (Lf)** — set as desired.

---

**Tip** To view the following fields, click in a blank space in the **Value** tab and drag the mouse upward.

- **Shaft Friction (Bf)** — set as desired.
- **Rotational Inertia (J)** — set as desired.
- **Rated Rotational Speed (NN)** — set as desired.
- **Load Torque (Tl)** — set as desired.

3. Click **OK**.

## A.1.9 Rated Relay



The magnetic relay is a coil with a specified inductance that causes a contact to open or close when a specified current ( $I_{on}$ ) charges it.

**Note** Refer to the *Component Reference Guide* for a more detailed discussion of relays.

➤ To adjust the component's tolerances:

1. Double-click on the placed component and click the **Value** tab.
2. Change the following values as desired:
  - **Animation Delay Factor** — increase this number to slow the speed of animation of the symbol blowing. This is not a real-time value.
  - **Coil Inductance** — set as desired.
  - **Coil Resistance** — set as desired.
  - **On Current ( $I_{on}$ )** — set as desired.
  - **Off Current ( $I_{off}$ )** — set as desired .
  - **Maximum Rated Voltage** — the maximum voltage allowed. If this value is exceeded during simulation, the relay blows.
  - **Maximum Rated Current** — the maximum current allowed. If this value is exceeded during simulation, the relay blows.
3. Click **OK**.

## A.1.10 Rated Opamp

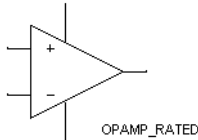

An ideal operational amplifier (Opamp) is an amplifier with infinite gain, infinite input impedance and zero output impedance. With the application of negative feedback, Opamps can be used to implement functions such as addition, subtraction, differentiation, integration, averaging and amplification.

An opamp can have a single input and single output, a differential input and single output, or a differential input and differential output.

**Note** Refer to the *Component Reference Guide* for a more detailed discussion of opamps.

- To adjust the component's tolerances:
  1. Double-click on the placed component and click the **Value** tab.
  2. Change the following values as desired:
    - **Animation Delay Factor** — increase this number to slow the speed of animation of the symbol blowing. This is not a real-time value.
    - **Maximum Supply Voltage (+/-)** — the maximum voltage (+/-) allowed. If this value is exceeded during simulation, the opamp blows.
    - **Maximum Input Voltage (+/-)** — the maximum input voltage (+/-) allowed. If this value is exceeded during simulation, the opamp blows.
    - **Maximum Differential Input Voltage** — the maximum differential input voltage allowed. If this value is exceeded during simulation, the opamp blows.
    - **Maximum Sink/Source Output Current** — If this value is exceeded during simulation, the opamp blows.
  3. Click **OK**.

---

## A.1.11 Rated Photodiode



The photodiode emits a source of infrared light which is detected by the phototransistor. These devices are intended to be used in pairs.

You must specify a light channel in each of these paired parts (photodiode and phototransistor). This is done in the **Value** tab of the component's properties screen. Each diode must have a different value for its light channel, however, the phototransistor can share the same value with several other phototransistors.

- To adjust the component's tolerances:
  1. Double-click on the placed component and click the **Value** tab.
  2. Change the following values as desired:
    - **Animation Delay Factor** — increase this number to slow the speed of animation of the symbol blowing. This is not a real-time value.
    - **Light Channel (Integer)** — set to match the light channel for the corresponding phototransistor(s).
    - **On Current (Ion)** — set as desired.
    - **Forward Voltage Drop (Vf)** — set as desired.
    - **Reverse Breakdown Voltage** — set as desired.
    - **Maximum Rated Power (Watts)** — If this value is exceeded during simulation, the photodiode blows.
  3. Click **OK**.

## A.1.12 Rated Phototransistor



The photodiode emits a source of infrared light which is detected by the phototransistor. These devices are are intended to be used in pairs.

You must specify a light channel in each of these paired parts (photodiode and phototransistor). This is done in the **Value** tab of the component's properties screen. Each diode must have a different value for its light channel, however, the phototransistor can share the same value with several other phototransistors.

- To adjust the component's tolerances:
  1. Double-click on the placed component and click the **Value** tab.
  2. Change the following values as desired:
    - **Animation Delay Factor** — increase this number to slow the speed of animation of the symbol blowing. This is not a real-time value.
    - **Light Channel (Integer)** — set to match the light channel for the corresponding photodiode.
    - **Maximum Collector-Emitter Voltage** — If this value is exceeded during simulation, the phototransistor blows.
    - **Maximum Collector Current** — If this value is exceeded during simulation, the phototransistor blows.
  3. Click **OK**.

## A.1.13 Rated Potentiometer

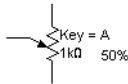

This component acts much like a tapped/split resistor, except that you can, with a single keystroke, adjust its resistance.

**Note** Refer to the *Component Reference Guide* for a more detailed discussion of potentiometers.

- To adjust the component's tolerances:
  1. Double-click on the placed component and click the **Value** tab.
  2. Change the following values as desired:
    - **Key** — enter the key that will increase the resistance by the amount set in the **Increment** field.
    - **Increment** — enter the amount by which the resistance will increase when the key set in the **Key** field is pressed.
    - **Animation Delay Factor** — increase this number to slow the speed of animation of the

---

symbol blowing. This is not a real-time value.

- **Resistance** — the maximum resistance of the potentiometer.
- **Maximum Rated Power (Watts)** — If this value is exceeded during simulation, the potentiometer blows.

3. Click **OK**.

## A.1.14 Rated Pullup

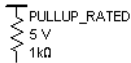

This component is used to raise the voltage of a circuit to which it is connected. One end is connected to  $V_{cc}$ . The other end is connected to a point in a logic circuit that needs to be raised to a voltage level closer to  $V_{cc}$ .

➤ To adjust the component's tolerances:

1. Double-click on the placed component and click the **Value** tab.
2. Change the following values as desired:
  - **Animation Delay Factor** — increase this number to slow the speed of animation of the symbol blowing. This is not a real-time value.
  - **Voltage (V)** — set as desired.
  - **Resistance** — set as desired.
  - **Maximum Rated Power (Watts)** — If this value is exceeded during simulation, the pullup blows.
3. Click **OK**.

## A.1.15 Rated Resistor



Resistors come in a variety of sizes, related to the power they can safely dissipate.

**Note** Refer to the *Component Reference Guide* for a more detailed discussion of resistors.

- To adjust the component's tolerances:
  1. Double-click on the placed component and click the **Value** tab.
  2. Change the following values as desired:
    - **Animation Delay Factor** — increase this number to slow the speed of animation of the symbol blowing. This is not a real-time value.
    - **Resistance** — set as desired.
    - **Maximum Rated Power (Watts)** — If this value is exceeded during simulation, the resistor blows.
    - **Temperature** — set as desired.
    - **Temperature Coefficient 1** — set as desired.
    - **Temperature Coefficient 2** — set as desired.
    - **Nominal Temperature** — set as desired.
  3. Click **OK**.

## A.1.16 Rated Transformers

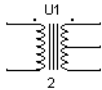

The transformer is one of the most common and useful applications of inductance. It can step up or step down an input primary voltage ( $V1$ ) to a secondary voltage ( $V2$ ). The relationship is given by  $V1/V2 = n$ , where  $n$  is the ratio of the primary turns to the secondary turns.

**Note** Refer to the *Component Reference Guide* for a more detailed discussion of transformers.

- To adjust the component's tolerances:
  1. Double-click on the placed component and click the **Value** tab.
  2. Change the following values as desired:
    - **Animation Delay Factor** — increase this number to slow the speed of animation of the symbol blowing. This is not a real-time value.
    - **Maximum Primary Voltage** — If this value is exceeded during simulation, the resistor blows.
    - **Maximum Primary Current** — If this value is exceeded during simulation, the resistor blows.
    - **Maximum Secondary 1 Voltage** — If this value is exceeded during simulation, the

---

resistor blows.

- **Maximum Secondary 1 Current** — If this value is exceeded during simulation, the resistor blows.
- **Maximum Secondary 2 Voltage** — If this value is exceeded during simulation, the resistor blows.
- **Maximum Secondary 2 Current** — If this value is exceeded during simulation, the resistor blows.
- **Maximum Output Power (kVA)** — If this value is exceeded during simulation, the resistor blows.
- **Primary-to-Secondary Turns Ratio** — set as desired.
- **Leakage Inductance (Le)** — set as desired.
- **Magnetizing Inductance (Lm)** — set as desired.

**Tip** To view the following fields, click in a blank space in the **Value** tab and drag the mouse upward.

- **Primary Winding Resistance** — set as desired.
- **Secondary Winding Resistance** — set as desired.

3. Click **OK**.

## A.1.17 Rated Variable Capacitor



This component acts much like a regular capacitor, except that you can, with a single keystroke, adjust its capacitance.

**Note** Refer to the *Component Reference Guide* for a more detailed discussion of capacitors.

➤ To adjust the component's tolerances:

1. Double-click on the placed component and click the **Value** tab.
2. Change the following values as desired:
  - **Key** — enter the key that will increase the capacitance by the amount set in the **Increment** field.
  - **Increment** — enter the amount by which the capacitance will increase when the key set in the **Key** field is pressed.
  - **Animation Delay Factor** — increase this number to slow the speed of animation of the symbol blowing. This is not a real-time value.

- **Capacitance** — the maximum capacitance of the variable capacitor.
  - **Initial Conditions** — the charge across the capacitor that is present before simulation starts.
  - **Voltage Rating (Pk)** — If this value is exceeded during simulation, the capacitor blows.
3. Click **OK**.

## A.1.18 Rated Variable Inductor

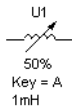

This component acts much like a regular inductor, except that you can, with a single keystroke, adjust its inductance.

**Note** Refer to the *Component Reference Guide* for a more detailed discussion of inductors.

- To adjust the component's tolerances:
  1. Double-click on the placed component and click the **Value** tab.
  2. Change the following values as desired:
    - **Key** — enter the key that will increase the inductance by the amount set in the **Increment** field.
    - **Increment** — enter the amount by which the inductance will increase when the key set in the **Key** field is pressed.
    - **Animation Delay Factor** — increase this number to slow the speed of animation of the symbol blowing. This is not a real-time value.
    - **Inductance** — the maximum inductance of the variable inductor.
    - **Coil Resistance** — set as desired.
    - **Initial Conditions** — the current through the inductor that is present before simulation starts.
    - **Current Rating (Pk)** — If this value is exceeded during simulation, the inductor blows.
  3. Click **OK**.

## A.1.19 Rated Virtual Components Toolbar

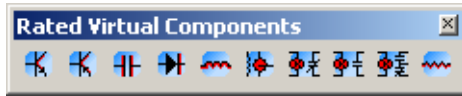

Some of the more commonly-used rated virtual components can be placed using the **Rated Virtual Components** toolbar.

- To display the **Rated Virtual Components** toolbar, click the **Show Rated Family** button in the **Virtual** toolbar (refer to the *Multisim 8 User Guide* for **Virtual** toolbar information).

The buttons (from left to right) in the **Rated Virtual Components** toolbar place the following virtual components: NPN transistor; PNP transistor; Capacitor; Diode; Inductor; Motor; normally closed relay; normally open relay; combination relay; resistor.

## A.2 3D Virtual Parts

This family contains a number of 3D parts. These components function normally when the circuit is simulated, but appear like the real component on the circuit schematic.

The 3D virtual components are found in the **Basic Group** in the **3D Rated Virtual** family as shown below.

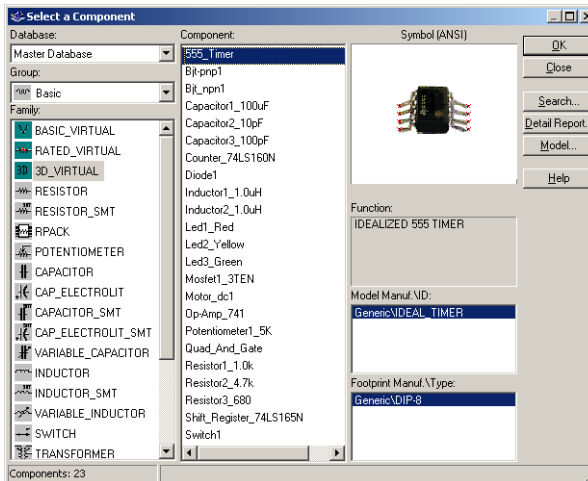

## A.2.1 3D 555 Timer



The 555 timer is an IC chip that is commonly used as an astable multivibrator, a monostable multivibrator or a voltage-controlled oscillator. The 555 timer consists basically of two comparators, a resistive voltage divider, a flip-flop and a discharge transistor. It is a two-state device whose output voltage level can be either high or low. The state of the output can be controlled by proper input signals and time-delay elements connected externally to the 555 timer.

**Note** Refer to the *Component Reference Guide* for a more detailed discussion of the 555 timer.

## A.2.2 3D BJT



A bipolar junction transistor, or BJT, is a current-based valve used for controlling electronic current. BJTs are operated in three different modes, depending on which element is common to input and output: common base, common emitter or common collector. The three modes have different input and output impedances and different current gains, offering individual advantages to a designer.

**Note** Refer to the *Component Reference Guide* for a more detailed discussion of BJTs.

---

## A.2.3 3D Capacitors



A capacitor stores electrical energy in the form of an electrostatic field. Capacitors are widely used to filter or remove AC signals from a variety of circuits. In a DC circuit, they can be used to block the flow of direct current while allowing AC signals to pass.

**Note** Refer to the *Component Reference Guide* for a more detailed discussion of capacitors.

## A.2.4 3D 74LS160N Counter

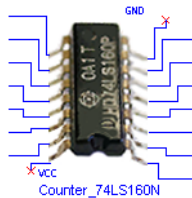

This synchronous, presettable decade counter features an internal carry look-ahead for fast counting.

**Note** Refer to the *Component Reference Guide* for a more detailed discussion of the 74LS160N counter.

## A.2.5 3D Diode



Diodes allow current to flow in only one direction and can therefore be used as simple solid-state switches in AC circuits, being either open (not conducting) or closed (conducting). Terminal A is called the anode and terminal K is called the cathode.

**Note** Refer to the *Component Reference Guide* for a more detailed discussion of diodes.

## A.2.6 3D Inductor



An inductor stores energy in an electromagnetic field created by changes in current through it. Its ability to oppose a change in current flow is called inductance,  $L$ , and is measured in Henries. An inductor can have any value from  $\mu\text{H}$  to H.

**Note** Refer to the *Component Reference Guide* for a more detailed discussion of inductors.

## A.2.7 3D LED



This diode emits visible light when forward current through it,  $I_d$ , exceeds the turn-on current,  $I_{on}$ . The electrical model of the LED is the same as the diode model.

**Note** Refer to the *Component Reference Guide* for a more detailed discussion of LEDs.

---

## A.2.8 3D MOSFET



A MOSFET is a Metal-Oxide-Semiconductor FET. This transistor is a type of FET that uses an induced electrical field to control current through the device. Either negative or positive gate voltages can be applied to control the current.

**Note** Refer to the *Component Reference Guide* for a more detailed discussion of MOSFETs.

## A.2.9 3D DC Motor



The component is a universal model of an ideal DC motor which can be used to model the behavior of a DC motor excited in parallel, in series or separately.

**Note** Refer to the *Component Reference Guide* for a more detailed discussion of DC motors.

## A.2.10 3D Opamp



An ideal operational amplifier (Opamp) is an amplifier with infinite gain, infinite input impedance and zero output impedance. With the application of negative feedback, Opamps can be used to implement functions such as addition, subtraction, differentiation, integration, averaging and amplification.

**Note** Refer to the *Component Reference Guide* for a more detailed discussion of opamps.

## A.2.11 3D Potentiometer



This component acts much like a regular resistor, except that you can, with a single keystroke, adjust its resistance.

**Note** Refer to the *Component Reference Guide* for a more detailed discussion of potentiometers.

## A.2.12 3D AND Gate

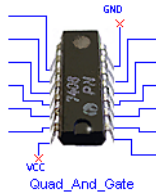

This device contains four independent 2-input AND gates.

**Note** Refer to the *Component Reference Guide* for a more detailed discussion of the 74LS08 Quad AND gate.

---

## A.2.13 3D Resistor



Resistors come in a variety of sizes, depending on the power they can safely dissipate. A resistor's resistance,  $R$ , is measured in ohms.

**Note** Refer to the *Component Reference Guide* for a more detailed discussion of resistors.

## A.2.14 3D Shift Register

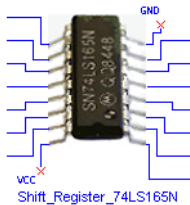

This serial shift-register shifts the data in the direction of QA toward QH when clocked. To load the data at the 8-inputs into the device, apply a low level at the shift/load input. This register is equipped with a complementary output at the eighth bit.

**Note** Refer to the *Component Reference Guide* for a more detailed discussion of the 74LS165N shift register.

## A.2.15 3D Switch



This component is a SPST (single-pole, single-throw) switch.

**Note** Refer to the *Component Reference Guide* for a more detailed discussion of switches.

## A.2.16 3D Components toolbar

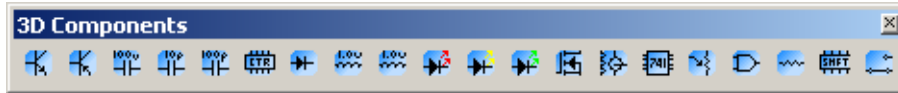

Some of the more commonly-used 3D components can be placed using the **3D Components** toolbar.

- To display the **3D Components** toolbar, click the **Show 3D Family** button in the **Virtual** toolbar (refer to the *Multisim 8 User Guide* for **Virtual** toolbar information).

The buttons (from left to right) in the **3D Components** toolbar place the following virtual components: NPN transistor; PNP transistor; 100 uF capacitor; 10 pF capacitor; 100 pF capacitor; 74LS160N counter; Diode ; 1 uH inductor; 1 uH inductor; Red LED; Yellow LED; Green LED; MOSFET; DC motor; 741 OPAMP; Potentiometer; Quad AND gate; 1.1 k Resistor; Shift Register 74LS165N; Switch.

## A.3 Ladder Diagram Parts

### A.3.1 Ladder Rungs

#### A.3.1.1 L1 and L2



L1 is a Rung Starter and L2 is a Rung Terminator. Continuity between L1 and L2 is required to activate/energize devices placed between them.

---

## A.3.2 Ladder I/O Modules

### A.3.2.1 Input Module

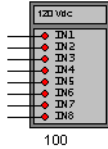

This device is an input module for ladder diagrams and is available in various input voltages. It is used to bring external stimulus into a ladder diagram.

- To set the Input Module's base address:
  1. Double-click on the module and select the **Value** tab.
  2. Enter the desired value in the **Input Module Base Address** field. The default value is 100, as shown in the above diagram.

### A.3.2.2 Output Module

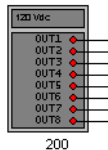

This device is an output module for ladder diagrams and is available in various output voltages. It allows external circuit elements to be manipulated by the logic contained in a ladder diagram.

- To set the Output Module's base address:
  1. Double-click on the module and select the **Value** tab.
  2. Enter the desired value in the **Output Module Base Address** field. The default value is 200, as shown in the above diagram.

## A.3.3 Ladder Relay Coils

### A.3.3.1 Relay Coil



This device is a relay coil for ladder diagrams. When this coil is energized, corresponding contact(s) which reference this device will change their state. (For example, a normally open contact will close).

- To set the coil reference for this device:
  1. Double-click on the relay coil and select the **Value** tab.
  2. Enter the desired value in the **Coil Reference** field.

### A.3.3.2 Negated Relay Coil



This device is a negated relay coil for ladder diagrams.

- To set the coil reference for this device:
  1. Double-click on the relay coil and select the **Value** tab.
  2. Enter the desired value in the **Coil Reference** field.

### A.3.3.3 Set Coil



This device is a latch relay coil for ladder diagrams (requires a reset coil to operate).

- To set the coil reference for this device:
  1. Double-click on the relay coil and select the **Value** tab.
  2. Enter the desired value in the **Coil Reference** field.

---

### A.3.3.4 Reset Coil



This device is an unlatch relay coil for ladder diagrams, used to reset timers, counters and set coils.

- To set the target device for this coil:
  1. Double-click on the set coil and select the **Value** tab.
  2. Enter the desired value in the **Target Device Reference** field.

### A.3.3.5 Pulsed Relay Coil



This device is a positive pulse relay coil, produce a positive pulse of user-definable duration.

- To set the parameters for this coil:
  1. Double-click on the positive pulse relay coil and select the **Value** tab.
  2. Enter the desired values in the **Coil Reference** and **Pulse Duration** fields.

## A.3.4 Ladder Contacts

### A.3.4.1 Input Contact NC

This device is a normally closed input contact for ladder diagrams. It responds to the status at the specified input on the referenced input module.

- To set the parameters for this device:
  1. Double-click on the input contact and select the **Value** tab.
  2. Enter the address of the input module associated with this contact (see “A.3.2.1 Input Module” on page A-24) in the **Input Module Base Address** field.

3. Enter the number of the input on the input module which will control this input contact in the **Input Number** field.

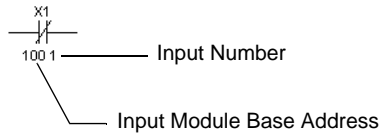

### A.3.4.2 Input Contact NO

This device is a normally open input contact for ladder diagrams. It responds to the status at the specified input on the referenced input module.

- To set the parameters for this device:
  1. Double-click on the input contact and select the **Value** tab.
  2. Enter the address of the input module associated with this contact (see “A.3.2.1 Input Module” on page A-24) in the **Input Module Base Address** field.
  3. Enter the number of the input on the input module which will control this input contact in the **Input Number** field.

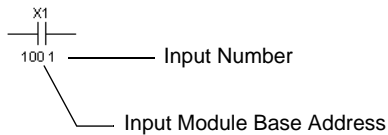

### A.3.4.3 Relay Contact NC



This device is a normally closed relay contact for ladder diagrams. This contact will open when the controlling device (coil, counter or timer) is energized.

- To set the parameters for this device:
  1. Double-click on the NC contact and select the **Value** tab.
  2. Enter the desired value in the **Controlling Device Reference** field.

---

## A.3.4.4 Relay Contact NO



This device is a normally open relay contact for ladder diagrams.

- To set the parameters for this device:
  1. Double-click on the relay contact and select the **Value** tab.
  2. Enter the desired value in the **Controlling Device Reference** field.

## A.3.5 Ladder Counters

### A.3.5.1 Count Off

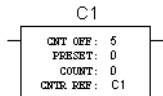

This device is a count OFF counter with preset, for ladder diagrams. The contact associated with this device will be energized at simulation start. The contact will be de-energized when the counter “Set Value” is reached.

This device does not retain its count out state and will automatically reset after count out occurs on the next action.

- To set the parameters for this device:
  1. Double-click on the counter and select the **Value** tab.
  2. Enter the following parameters:
    - **Set Value** — the counter’s count out value.
    - **Preset Value** — the count starting point.
    - **Counter Reference** — set to the device’s **RefDes** by default. You can enter any other identifying string.

### A.3.5.2 Count Off Hold

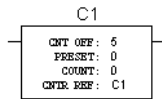

This device is a count OFF and hold counter with preset, for ladder diagrams. The contact associated with this device will be energized at simulation start. The contact will be de-energized when the counter “Set Value” is reached.

Once the count out state is reached, the counter status is held until simulation is restarted.

- To set the parameters for this device:
  1. Double-click on the counter and select the **Value** tab.
  2. Enter the following parameters:
    - **Set Value** — the counter’s count out value.
    - **Preset Value** — the count starting point.
    - **Counter Reference** — set to the device’s **RefDes** by default. You can enter any other identifying string.

### A.3.5.3 Count Off Reset

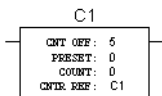

This device is a count OFF and hold until reset counter with preset, for ladder diagrams. The contact associated with this device will be energized at simulation start. The contact will be de-energized when the counter “Set Value” is reached.

You can reset this counter using a reset coil at any time during simulation, regardless of the current counter state.

- To set the parameters for this device:
  1. Double-click on the counter and select the **Value** tab.
  2. Enter the following parameters:
    - **Set Value** — the counter’s count out value.
    - **Preset Value** — the count starting point.
    - **Counter Reference** — set to the device’s **RefDes** by default. You can enter any other

identifying string.

### A.3.5.4 Count Off Up Down

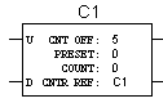

This device is a resettable up/down count OFF and hold until reset counter with preset, for ladder diagrams. This bi-directional counter increments the count via the “U” input, and decrements the count via the “D” input.

- To set the parameters for this device:
  1. Double-click on the counter and select the **Value** tab.
  2. Enter the following parameters:
    - **Set Value** — the counter’s count out value.
    - **Preset Value** — the count starting point.
    - **Counter Reference** — set to the device’s **RefDes** by default. You can enter any other identifying string.

### A.3.5.5 Count On

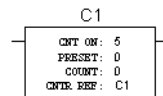

This device is a count ON counter with preset, for ladder diagrams. The contact associated with this device will be de-energized at simulation start. The contact will be re-energized when the counter “Set Value” is reached.

This device does not retain its count out state and will automatically reset after count out occurs on the next action.

- To set the parameters for this device:
  1. Double-click on the counter and select the **Value** tab.
  2. Enter the following parameters:
    - **Set Value** — the counter’s count out value.
    - **Preset Value** — the count starting point.

- **Counter Reference** — set to the device’s **RefDes** by default. You can enter any other identifying string.

### A.3.5.6 Count On Hold

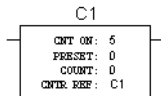

This device is a count ON and hold counter with preset, for ladder diagrams. The contact associated with this device will be de-energized at simulation start. The contact will be energized when the counter “Set Value” is reached.

Once the count out state is reached, the counter status is held until simulation is restarted.

- To set the parameters for this device:
  1. Double-click on the counter and select the **Value** tab.
  2. Enter the following parameters:
    - **Set Value** — the counter’s count out value.
    - **Preset Value** — the count starting point.
    - **Counter Reference** — set to the device’s **RefDes** by default. You can enter any other identifying string.

### A.3.5.7 Count On Reset

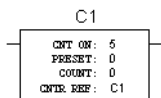

This device is a count ON and hold until reset counter with preset, for ladder diagrams. The contact associated with this device will be de-energized at simulation start. The contact will be energized when the counter “Set Value” is reached.

You can reset this counter using a reset coil at any time during simulation, regardless of the current counter state.

- To set the parameters for this device:
  1. Double-click on the counter and select the **Value** tab.

2. Enter the following parameters:

- **Set Value** — the counter’s count out value.
- **Preset Value** — the count starting point.
- **Counter Reference** — set to the device’s **RefDes** by default. You can enter any other identifying string.

## A.3.5.8 Count On Up Down

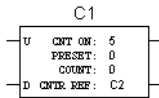

This device is a resettable up/down count ON and hold until reset counter with preset, for ladder diagrams. This bi-directional counter increments the count via the “U” input, and decrements the count via the “D” input.

➤ To set the parameters for this device:

1. Double-click on the counter and select the **Value** tab.

2. Enter the following parameters:

- **Set Value** — the counter’s count out value.
- **Preset Value** — the count starting point.
- **Counter Reference** — set to the device’s **RefDes** by default. You can enter any other identifying string.

## A.3.6 Ladder Timers

### A.3.6.1 Timer TOFF

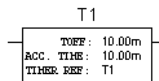

This device is a TOFF timer for ladder diagrams. The associated contact is energized at the start of simulation, and is de-energized when this device “times out”. Any interruption in

continuity on the rung in which this timer is located causes the time value to be reset to zero. (This occurs whether or not the timer has timed out).

- To set the parameters for this device:
  1. Double-click on the timer and select the **Value** tab.
  2. Enter the following parameters:
    - **Delay Time** — the timer’s time out value.
    - **Timer Reference** — set to the device’s **RefDes** by default. You can enter any other identifying string.

### A.3.6.2 Timer TON

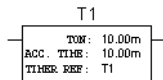

This device is a TON timer for ladder diagrams. The associated contact is de-energized at the start of simulation, and is energized when this device “times out”. Any interruption in continuity on the rung in which this timer is located causes the time value to be reset to zero. (This occurs whether or not the timer has timed out).

- To set the parameters for this device:
  1. Double-click on the timer and select the **Value** tab.
  2. Enter the following parameters:
    - **Delay Time** — the timer’s time out value.
    - **Timer Reference** — set to the device’s **RefDes** by default. You can enter any other identifying string.

### A.3.6.3 Timer TON Retention

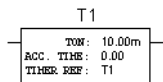

This device is a TON timer with retention capabilities, for ladder diagrams. Once continuity is established, the timer starts. If continuity is broken, the timer retains the accumulated time and will continue from this time when continuity is re-established, until time out. Once timed out, the timer will reset if continuity is broken, and will start accumulated time at zero.

- 
- To set the parameters for this device:
    1. Double-click on the timer and select the **Value** tab.
    2. Enter the following parameters:
      - **Delay Time** — the timer’s time out value.
      - **Timer Reference** — set to the device’s **RefDes** by default. You can enter any other identifying string.

### A.3.6.4 Timer TON Retention Reset

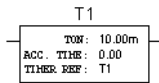

This device is a TON timer with retention and reset capabilities, for ladder diagrams. Once continuity is established, the timer starts. If continuity is broken, the timer retains the accumulated time and will continue from this time when continuity is re-established, until time out. Once timed out, the timer will reset automatically if continuity is removed. This device can be reset by a reset coil at any time before time out.

- To set the parameters for this device:
  1. Double-click on the timer and select the **Value** tab.
  2. Enter the following parameters:
    - **Delay Time** — the timer’s time out value.
    - **Timer Reference** — set to the device’s **RefDes** by default. You can enter any other identifying string.

### A.3.6.5 Timer TON Retention Hold Reset

This device is a TON timer with retention, hold and reset capabilities, for ladder diagrams. Once continuity is established, the timer starts. If continuity is broken, the timer retains the accumulated time and will continue from this time when continuity is re-established, until time out. Once timed out, the timer will not reset automatically when continuity is removed. This device can be reset by a reset coil at any time.

- To set the parameters for this device:
  1. Double-click on the timer and select the **Value** tab.
  2. Enter the following parameters:
    - **Delay Time** — the timer’s time out value.
    - **Timer Reference** — set to the device’s **RefDes** by default. You can enter any other identifying string.

## A.3.7 Ladder Output Coils

### A.3.7.1 Output Coil

This device is an output coil for ladder diagrams.

- To set the parameters for this device:
  1. Double-click on the output coil and select the **Value** tab.
  2. Enter the address for the output module associated with this device in the **Output Module Base Address** field.
  3. Enter the number of the output on the output module that this device will drive in the **Output Number** field.

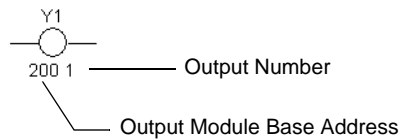

### A.3.7.2 Output Coil Negated

This device is a negated output coil for ladder diagrams.

- To set the parameters for this device:
  1. Double-click on the output coil and select the **Value** tab.
  2. Enter the address for the output module associated with this device in the **Output Module Base Address** field.
  3. Enter the number of the output on the output module that this device will drive in the **Output Number** field.

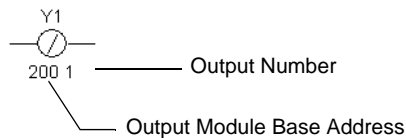

## A.3.8 Ladder Output Devices

### A.3.8.1 Holding Tank

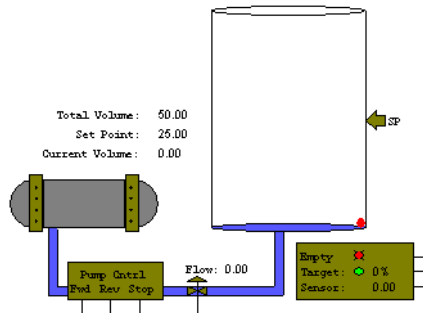

This device is a liquid holding tank for use in ladder diagrams.

➤ To set the parameters for this device:

1. Double-click on the relay coil and select the **Value** tab.
2. Set the following parameters as desired:
  - **Tank Volume (litres)** — capacity of the tank in litres.
  - **Level Detector Set Point (litres)** — the level of the SP (set point) marker (see above screen capture).
  - **Maximum Pump Flow Rate (litres/second)** — the maximum speed at which the liquid is pumped into the holding tank. If the **Flow** pin of the holding tank (see above screen capture) is unconnected, the liquid only flows at this speed.
  - **Flow Rate Full Scale Voltage** — if the **Flow** pin of the holding tank is connected, this is the voltage required at the **Flow** pin to make the liquid move at the maximum speed set in the **Maximum Pump Flow Rate** field. For example, if you enter 5 V in this field, and then apply 5 V to the **Flow** pin, the liquid will flow at 1 litre/second if the value in the **Maximum Pump Flow Rate** field is 1. If you apply 2.5 V to the **Flow** pin, the liquid will flow at half that speed (0.5 litre/second).
  - **Sensor Full Scale Voltage** — the sensor voltage that equates to a full tank. As the tank fills, the voltage shown in the **Sensor** field of the holding tank (see above screen capture) increases.

**Note** For an example of this component in a complete circuit, refer to “3.4.1 Holding Tank” on page 3-7.

### A.3.8.2 Conveyor Belt

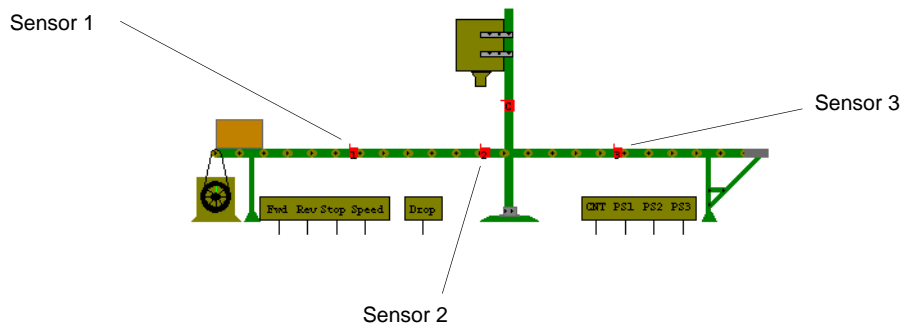

This device is a conveyor belt for use in ladder diagrams.

- To set the parameters for this device:
    1. Double-click on the relay coil and select the **Value** tab.
    2. Set the following parameters as desired:
      - **Belt Length (meters)** — the length of the conveyor belt in meters.
      - **Max. Belt Speed (meters/sec)** — the maximum speed the belt moves. If the **Speed** pin of the conveyor belt (see above screen capture) is unconnected, the belt only moves at this speed.
      - **Speed Control Full Scale Voltage** — if the **Speed** pin of the conveyor belt is connected, this is the voltage required at the **Speed** pin to make the belt move at the maximum speed set in the **Max. Belt Speed** field. For example, if you enter 5 V in this field, and then apply 5 V to the **Speed** pin, the belt will move at 0.5 meters/second if the value in the **Max. Belt Speed** field is 0.5. If you apply 2.5 V to the **Speed** pin, the belt will move at half that speed (0.25 meters per second).
      - **Sensor 1 Position (meters)** — the position of Sensor 1 from the left edge of the belt.
      - **Sensor 2 Position (meters)** — the position of Sensor 2 from the left edge of the belt.
      - **Sensor 3 Position (meters)** — the position of Sensor 3 from the left edge of the belt. Do not set greater than the **Belt Length** value.
- Note** For an example of this component in a complete circuit, see “3.4.2 Conveyor Belt” on page 3-12.

---

### A.3.8.3 Traffic Light

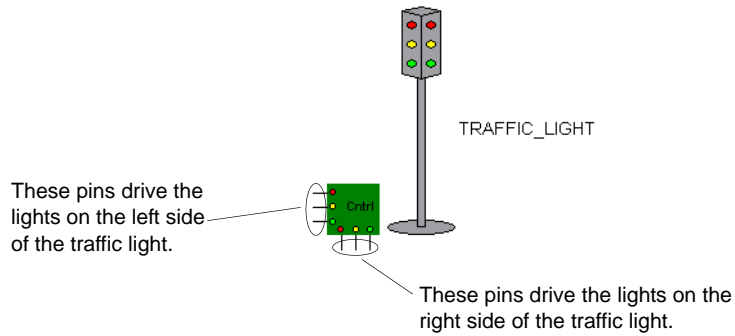

This component has no parameters that need to be set up in the **Value** tab.

**Note** For an example of this component in a complete circuit, see “3.4.3 Traffic Light” on page 3-17.

# Index

## Numerics

### 3D Components

- 555 timer A-17
- 74LS160N counter A-18
- BJT A-17
- capacitor A-18
- DC motor A-20
- diode A-19
- inductor A-19
- LED A-19
- MOSFET A-20
- opamp A-21
- potentiometer A-21
- resistor A-22
- shift register A-22

### 3D Components toolbar A-23

## A

- assigning faults to components 1-2
- Auto Fault option 1-3

## B

- Breadboard Netlist dialog box 2-13
- Breadboard Settings 2-3

## C

- circuit restrictions
  - setting 1-9
- components
  - assigning faults 1-2
  - Auto Fault option 1-3
- Conveyor Belt A-37
- Count Off A-28
- Count Off Hold A-29
- Count Off Reset A-29
- Count Off Up Down A-30
- Count On A-30
- Count On Hold A-31

### Count On Reset A-31

### Count On Up Down A-32

## F

- faults, assigning to components 1-2

## G

- global restrictions
  - passwords 1-12
  - setting 1-4

## I

- Input Module A-24

## L

- Liquid Holding Tank A-36

## N

- Negated Output Coil A-35
- Negated Relay Coil A-25
- Normally Closed Input Contact A-26
- Normally Closed Relay Contact A-27
- Normally Open Input Contact A-27
- Normally Open Relay Contact A-28

## O

- Output Coil A-35
- Output Module A-24

## P

- passwords, creating/changing 1-12
- Pulsed Relay Coil A-26

## R

- Rated Components
  - 555 timer A-2
  - BJT A-3

---

- capacitor A-4
- DC motor A-7
- diode A-4
- fuse A-5
- inductor A-6
- LED A-6
- opamp A-9
- Photodiode A-10
- Phototransistor A-10
- potentiometer A-11
- pullup A-12
- relay A-8
- transformer A-13
- variable capacitor A-14
- variable inductor A-15
- Rated Virtual Components toolbar A-16
- Relay Coil A-25
- Reset Coil A-26
- restrictions
  - about 1-4
  - setting circuit 1-9
  - setting global 1-4

## **S**

- Set Coil A-25
- setting circuit restrictions 1-9
- setting global restrictions 1-4
- Simplified Version 1-4

## **T**

- TOFF timer A-32
- TON timer A-33
- TON timer with retention A-33
- TON timer with retention and reset A-34
- TON timer with retention, hold and reset A-34
- Traffic Light A-38