



ITU02N70A ITD02N70A

N-Channel MOSFET

Pb Lead Free Package and Finish

Applications:

- Adaptor
- Charger
- SMPS Standby Power
- LCD Panel Power

V_{DSS}	$R_{DS(ON)}$ (Typ.)	I_D
700V	5.0 Ω	2.0A

Features:

- RoHS Compliant
- Low ON Resistance
- Low Gate Charge
- Peak Current vs Pulse Width Curve
- Inductive Switching Curves

Ordering Information

PART NUMBER	PACKAGE	BRAND
ITU02N70A	TO-251	ITU02N70A
ITD02N70A	TO-252	ITD02N70A

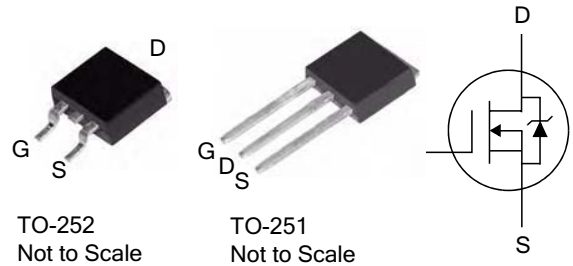

Absolute Maximum Ratings $T_C=25^\circ\text{C}$ unless otherwise specified

Symbol	Parameter	ITU02N70A	ITD02N70A	Units
V_{DSS}	Drain-to-Source Voltage (NOTE *1)	700		V
I_D	Continuous Drain Current	2.0	2.0*	A
$I_{D@100^\circ\text{C}}$	Continuous Drain Current	Figure 3		
I_{DM}	Pulsed Drain Current, $V_{GS}@10\text{V}$ (NOTE *2)	Figure 6		
P_D	Power Dissipation	55	55	W
	Derating Factor above 25°C	0.43	0.43	W/ $^\circ\text{C}$
V_{GS}	Gate-to-Source Voltage	± 30		V
E_{AS}	Single Pulse Avalanche Energy L=10 mH	70		mJ
I_{AS}	Pulsed Avalanche Rating	Figure 8		
dv/dt	Peak Diode Recovery dv/dt (NOTE *3)	5.0		V/ns
T_L T_{PKG}	Maximum Temperature for Soldering Leads at 0.063in (1.6mm) from Case for 10 seconds Package Body for 10 seconds	300 260		$^\circ\text{C}$
T_J and T_{STG}	Operating Junction and Storage Temperature Range	-55 to 150		

*Drain Current limited by Maximum Junction Temperature.

Caution: Stresses greater than those listed in the "Absolute Maximum Ratings" Table may cause permanent damage to the device.

Thermal Resistance

Symbol	Parameter	ITU02N70A	ITD02N70A	Units	Test Conditions
$R_{\theta JC}$	Junction-to-Case	2.3	2.3	$^\circ\text{C}/\text{W}$	Water cooled heatsink, P_D adjusted for a peak junction temperature of $+150^\circ\text{C}$.
$R_{\theta JA}$	Junction-to-Ambient	62.5	62.5		1 cubic foot chamber, free air.

OFF Characteristics $T_c=25^\circ\text{C}$ unless otherwise specified

Symbol	Parameter	Min.	Typ.	Max.	Units	Test Conditions
BV_{DSS}	Drain-to-Source Breakdown Voltage	700	--	--	V	$V_{GS}=0V, I_D=250\mu A$
$\Delta BV_{DSS}/\Delta T_J$	Breakdown Voltage Temperature Coefficient, Figure 11.	--	0.65	--	V/°C	Reference to 25°C , $I_D=250\mu A$
I_{DSS}	Drain-to-Source Leakage Current	--	--	1.0	μA	$V_{DS}=700V, V_{GS}=0V$
		--	--	250		$V_{DS}=560V, V_{GS}=0V$ $T_J=125^\circ\text{C}$
I_{GSS}	Gate-to-Source Forward Leakage	--	--	100	nA	$V_{GS}=+30V$
	Gate-to-Source Reverse Leakage	--	--	-100		$V_{GS}=-30V$

ON Characteristics $T_c=25^\circ\text{C}$ unless otherwise specified

Symbol	Parameter	Min.	Typ.	Max.	Units	Test Conditions
$R_{DS(ON)}$	Static Drain-to-Source On-Resistance Figure 9 and 10.	--	5.0	6.5	Ω	$V_{GS}=10V, I_D=1.0A$ (NOTE *4)
$V_{GS(TH)}$	Gate Threshold Voltage, Figure 12.	2.0	--	4.0	V	$V_{DS}=V_{GS}, I_D=250\mu A$
gfs	Forward Transconductance	--	2.6	--	S	$V_{DS}=15V, I_D=2.0A$ (NOTE *4)

Dynamic Characteristics Essentially independent of operating temperature

Symbol	Parameter	Min.	Typ.	Max.	Units	Test Conditions
C_{iss}	Input Capacitance	--	300	--	pF	$V_{GS}=0V$ $V_{DS}=25V$ $f=1.0MHz$ Figure 14
C_{oss}	Output Capacitance	--	32	--		
C_{riss}	Reverse Transfer Capacitance	--	4.0	--		
Q_g	Total Gate Charge	--	9.0	--	nC	$V_{DD}=350V$ $I_D=2.0A$ Figure 15
Q_{gs}	Gate-to-Source Charge	--	2.0	--		
Q_{gd}	Gate-to-Drain ("Miller") Charge	--	4.0	--		

Resistive Switching Characteristics Essentially independent of operating temperature

Symbol	Parameter	Min.	Typ.	Max.	Units	Test Conditions
$t_{d(ON)}$	Turn-on Delay Time	--	9.0	--	ns	$V_{DD}=350V$ $I_D=2.0A$ $V_{GS}=10V$ $R_G=25\Omega$
t_{rise}	Rise Time	--	10	--		
$t_{d(OFF)}$	Turn-Off Delay Time	--	31	--		
t_{fall}	Fall Time	--	16	--		

Source-Drain Diode Characteristics $T_C=25^\circ\text{C}$ unless otherwise specified

Symbol	Parameter	Min.	Typ.	Max.	Units	Test Conditions
I_S	Continuous Source Current (Body Diode)	--	--	2.0	A	Integral pn-diode in MOSFET
I_{SM}	Maximum Pulsed Current (Body Diode)	--	--	8.0	A	
V_{SD}	Diode Forward Voltage	--	--	1.5	V	$I_S=2.0\text{A}$, $V_{GS}=0\text{V}$
t_{rr}	Reverse Recovery Time	--	485	--	ns	$V_{GS}=0\text{V}$
Q_{rr}	Reverse Recovery Charge	--	1.3	--	μC	$I_F=2.0\text{A}$, $di/dt=100\text{A}/\mu\text{s}$

Notes:

-
- *1. $T_J = +25^\circ\text{C}$ to $+150^\circ\text{C}$.
 - *2. Repetitive rating; pulse width limited by maximum junction temperature.
 - *3. $I_{SD}= 2.0\text{A}$ $di/dt \leq 100\text{A}/\mu\text{s}$, $V_{DD} \leq BV_{DSS}$, $T_J=+150^\circ\text{C}$.
 - *4. Pulse width $\leq 380\mu\text{s}$; duty cycle $\leq 2\%$.

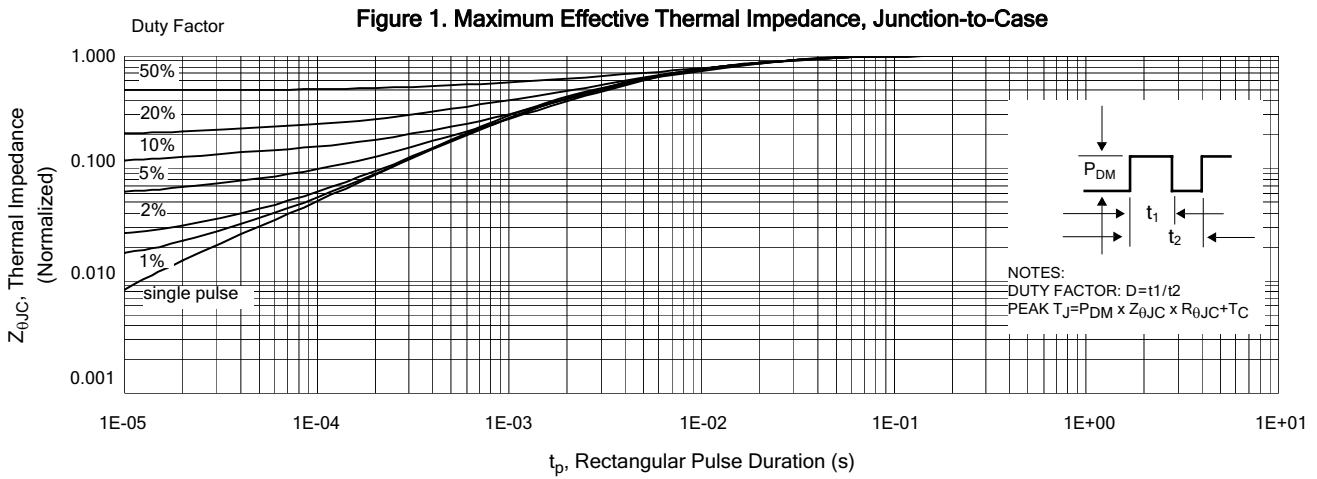

Figure 2. Maximum Power Dissipation vs Case Temperature

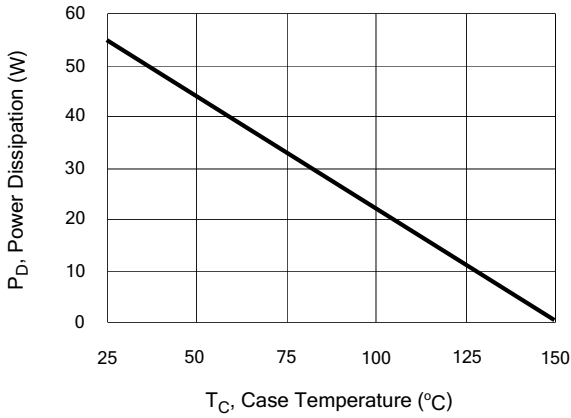

Figure 3. Maximum Continuous Drain Current vs Case Temperature

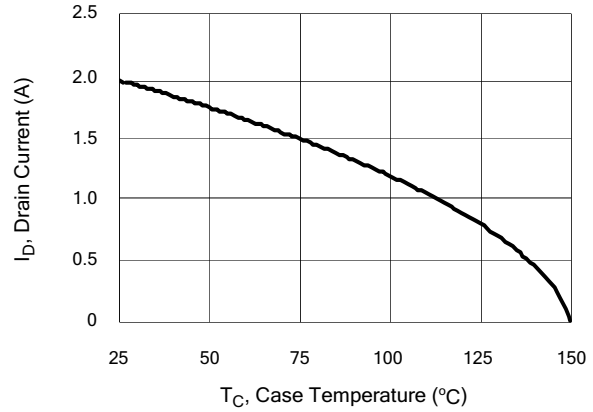

Figure 4. Typical Output Characteristics

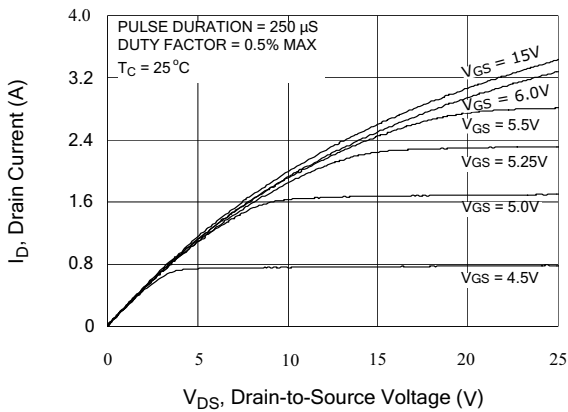

Figure 5. Typical Drain-to-Source ON Resistance vs Gate Voltage and Drain Current

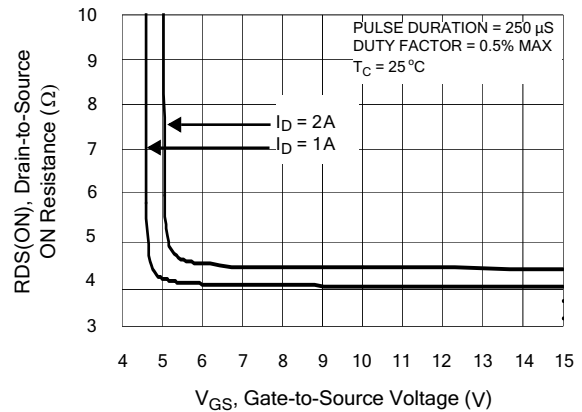

Figure 6. Maximum Peak Current Capability

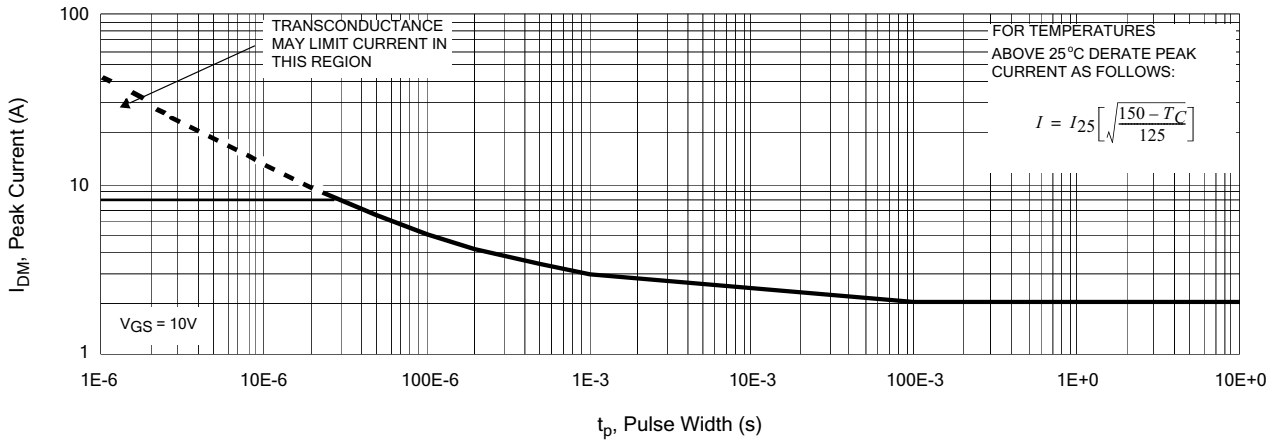

Figure 7. Typical Transfer Characteristics

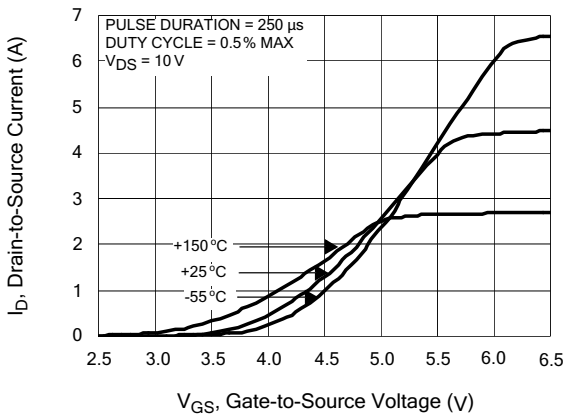

Figure 8. Unclamped Inductive Switching Capability

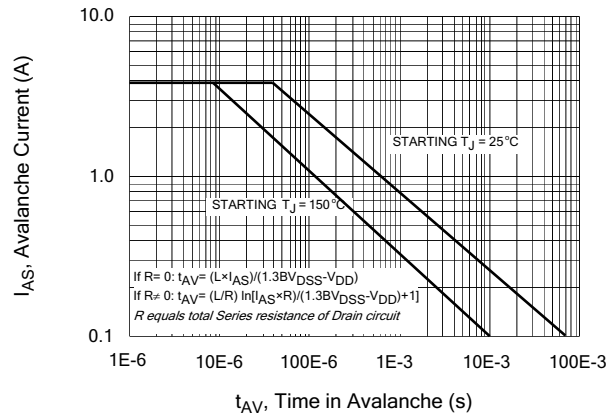

Figure 9. Typical Drain-to-Source ON Resistance vs Drain Current

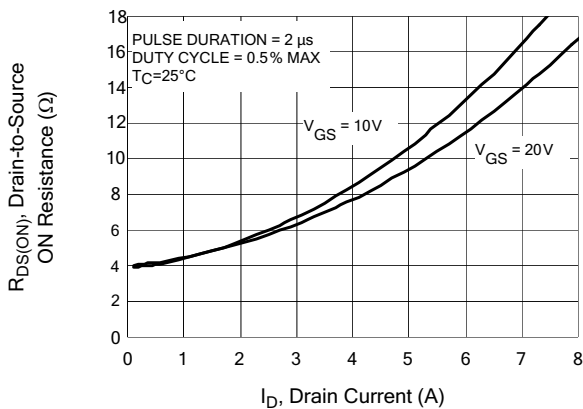

Figure 10. Typical Drain-to-Source ON Resistance vs Junction Temperature

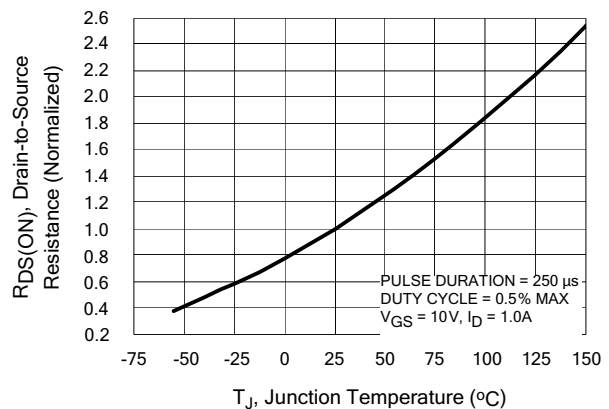

Figure 11. Typical Breakdown Voltage vs Junction Temperature

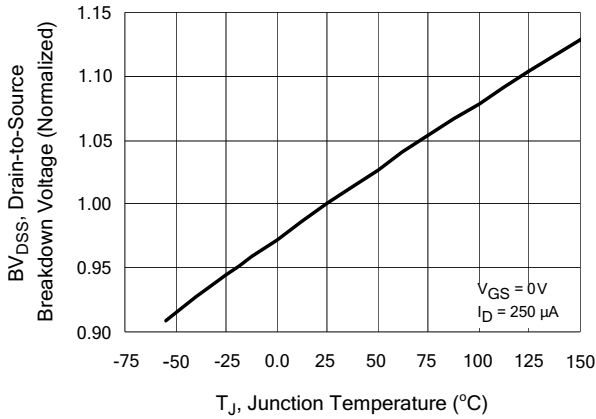

Figure 12. Typical Threshold Voltage vs Junction Temperature

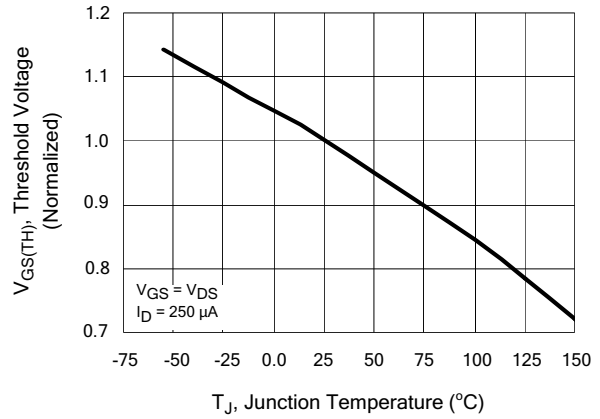

Figure 13. Maximum Forward Bias Safe Operating Area

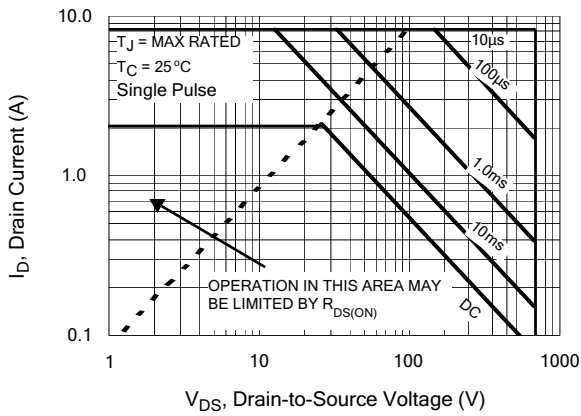

Figure 14. Typical Capacitance vs Drain-to-Source Voltage

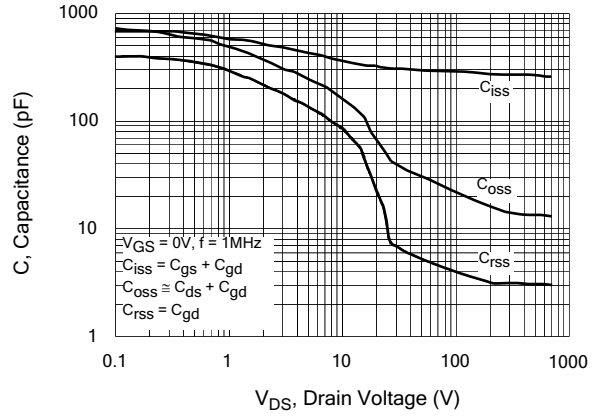

Figure 15. Typical Gate Charge vs Gate-to-Source Voltage

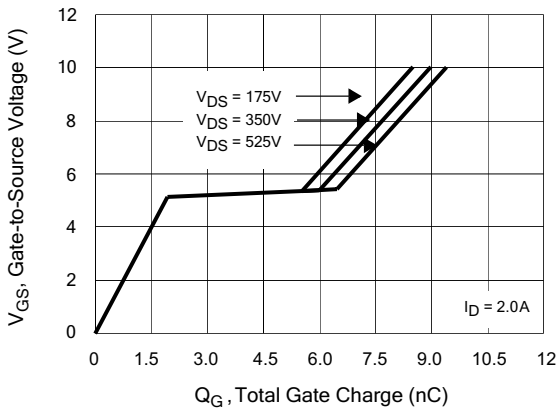
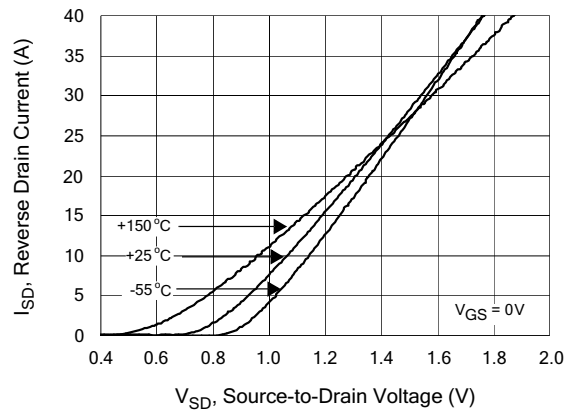

Figure 16. Typical Body Diode Transfer Characteristics



Test Circuits and Waveforms

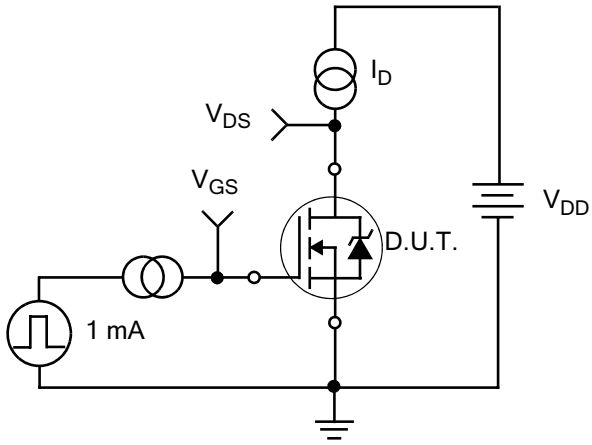

Figure 17. Gate Charge Test Circuit

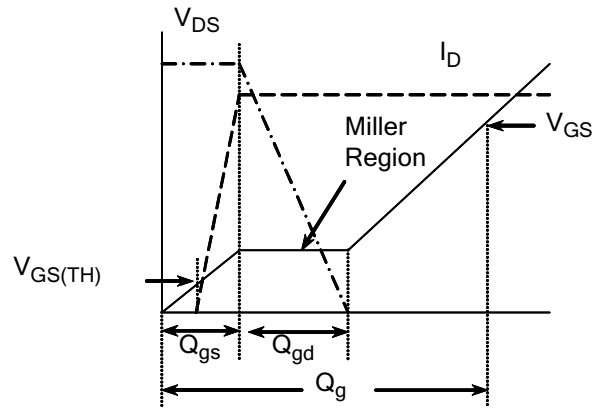

Figure 18. Gate Charge Waveform

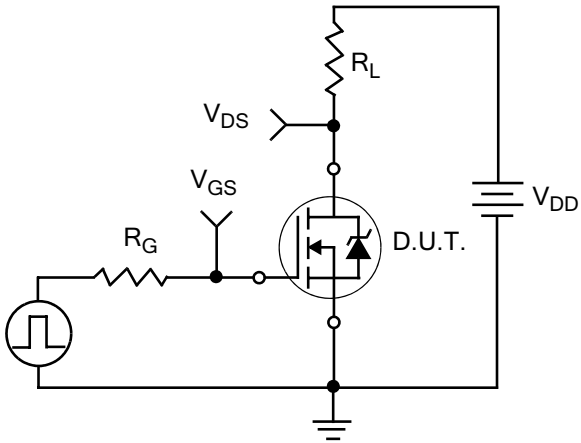

Figure 19. Resistive Switching Test Circuit

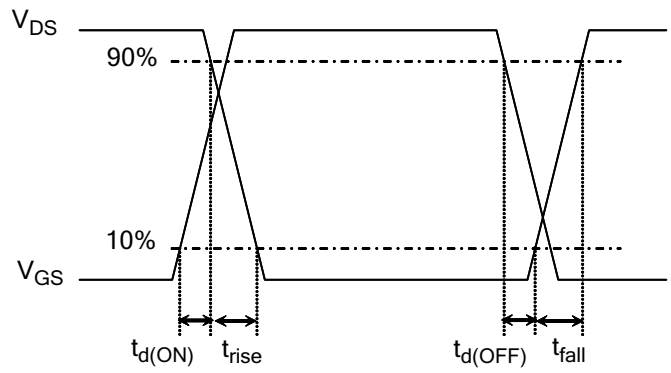

Figure 20. Resistive Switching Waveforms

Test Circuits and Waveforms

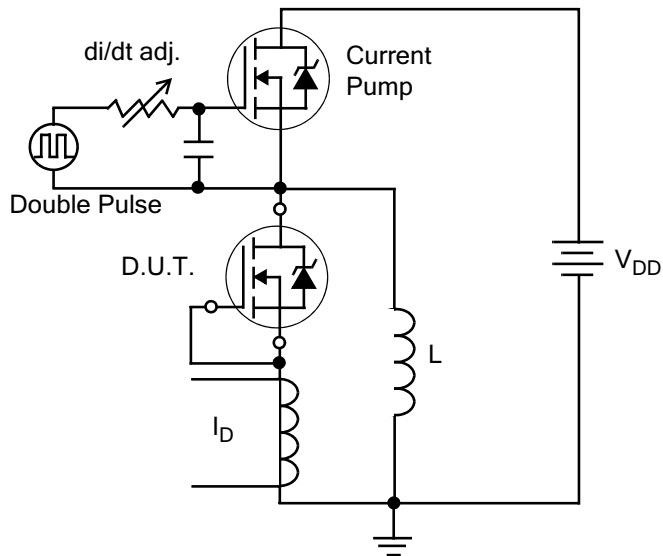

Figure 21. Diode Reverse Recovery Test Circuit

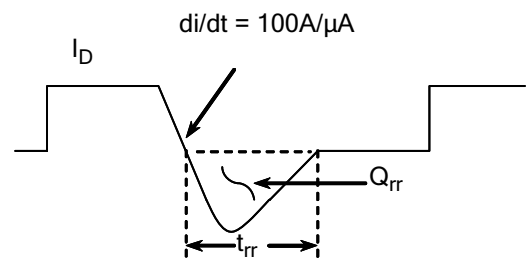

Figure 22. Diode Reverse Recovery Waveform

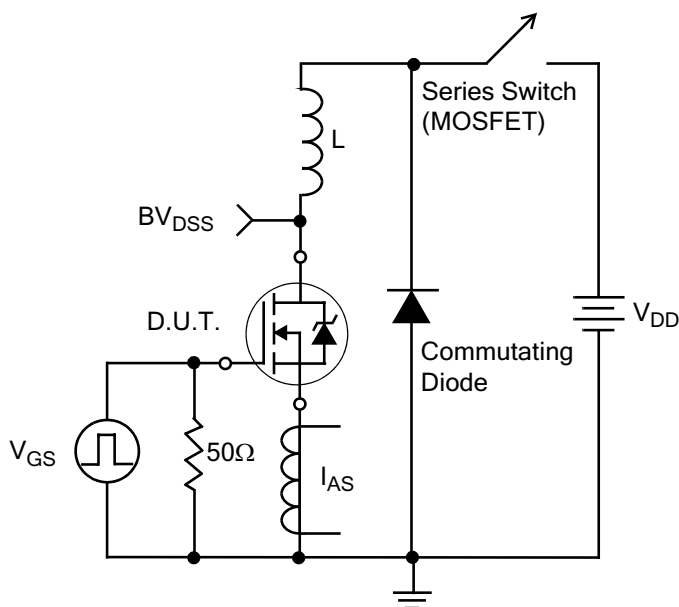

Figure 23. Unclamped Inductive Switching Test Circuit

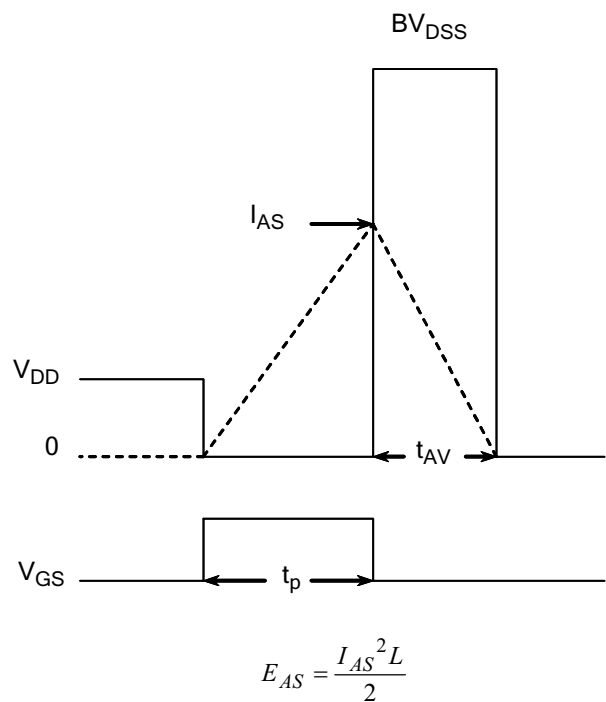

Figure 24. Unclamped Inductive Switching Waveforms

Disclaimers:

InPower Semiconductor Co., Ltd (IPS) reserves the right to make changes without notice in order to improve reliability, function or design and to discontinue any product or service without notice. Customers should obtain the latest relevant information before orders and should verify that such information is current and complete. All products are sold subject to IPS's terms and conditions supplied at the time of order acknowledgement.

InPower Semiconductor Co., Ltd warrants performance of its hardware products to the specifications at the time of sale. Testing, reliability and quality control are used to the extent IPS deems necessary to support this warranty. Except where agreed upon by contractual agreement, testing of all parameters of each product is not necessarily performed.

InPower Semiconductor Co., Ltd does not assume any liability arising from the use of any product or circuit designs described herein. Customers are responsible for their products and applications using IPS's components. To minimize risk, customers must provide adequate design and operating safeguards.

InPower Semiconductor Co., Ltd does not warrant or convey any license either expressed or implied under its patent rights, nor the rights of others. Reproduction of information in IPS's data sheets or data books is permissible only if reproduction is without modification or alteration. Reproduction of this information with any alteration is an unfair and deceptive business practice. InPower Semiconductor Co., Ltd is not responsible or liable for such altered documentation.

Resale of IPS's products with statements different from or beyond the parameters stated by InPower Semiconductor Co., Ltd for that product or service voids all express or implied warranties for the associated IPS's product or service and is unfair and deceptive business practice. InPower Semiconductor Co., Ltd is not responsible or liable for any such statements.

Life Support Policy:

InPower Semiconductor Co., Ltd's products are not authorized for use as critical components in life support devices or systems without the expressed written approval of InPower Semiconductor Co., Ltd.

As used herein:

1. Life support devices or systems are devices or systems which:
 - a. are intended for surgical implant into the human body,
 - b. support or sustain life,
 - c. whose failure to perform when properly used in accordance with instructions for used provided in the labeling, can be reasonably expected to result in significant injury to the user.
2. A critical component is any component of a life support device or system whose failure to perform can be reasonably expected to cause the failure of the life support device or system, or to affect its safety or effectiveness.